

Pro Park 8S Quick Assembly Guide



All images and other materials are protected by United States copyright law and may not be reproduced, distributed, transmitted, displayed, published or broadcast without the prior written permission from Greg Smith Equipment Sales, Inc. You may not alter or remove any trademark, copyright or other notice from copies of the content.

STEP 1:

*Click on each picture for a larger view.



Lift assembly requires a 30 foot work area. You will need one of the following to complete this project:

An assistant, a cherry picker, or a fork truck.

Assembly will take approximately 4 hours.

You will need a metric wrench set and 4 foot level.

You will need 3 gallons of medium viscosity (AW 32 or AW 46) hydraulic fluid.

Please read this manual before you begin to assemble your lift.

STEP 2:



Direct Lift Pro Park 8 S that was just unloaded off of a freight truck or a trailer.

Power Unit (110 volt) is packaged inside the lift. The caster kit and the jack trays are packaged inside the lift crate. The plastic drip drays are in the thin and lightweight card board box. Lift package is about 14 feet long.

The heaviest piece is the cylinder runway: 440 LB.

The columns weigh about 100 pounds each.
Off runway: 300 LB.

We suggest that two people and appropriate lifting equipment are used to make this job as easy as possible.

STEP 3:

*Click on each picture for a larger view.



The package contains 2 crossbeams, 1 cylinder runway, 1 runway without cylinder, 4 columns, and 2 approach ramps.

IMPORTANT

Before you begin assembly, you will need to pull the ram (piston) end out of the cylinder (under the runway) as far as possible (this will make it easier to route your cables when needed).

The ram (piston) can be extended by one or two people holding the plate attached to the ram and pulling it straight out from the cylinder.

STEP 4:



Your package will also contain 4 lock ladders with corresponding nuts to fit on threaded top rod, 1 steel jack tray, 4 cables of different lengths, 4 spacing brackets, 4 stop plates, 1 hydraulic hose, 4 lock pins for the casters, 1 110 volt power unit **(DO NOT FILL POWER UNIT WITH HYDRAULIC FLUID UNTIL IT HAS BEEN MOUNTED ON THE LIFT)**, the lock rod assembly and all appropriate hardware. The 3 plastic drip trays are in a separate package.

STEP 5:

*Click on each picture for a larger view.



Lay one crossbeam flat on the ground, make sure the large interior pulleys are facing up, and then lay out two of the columns so the bases are away from the cross tube.

Open side of the column should be facing in.

STEP 6:

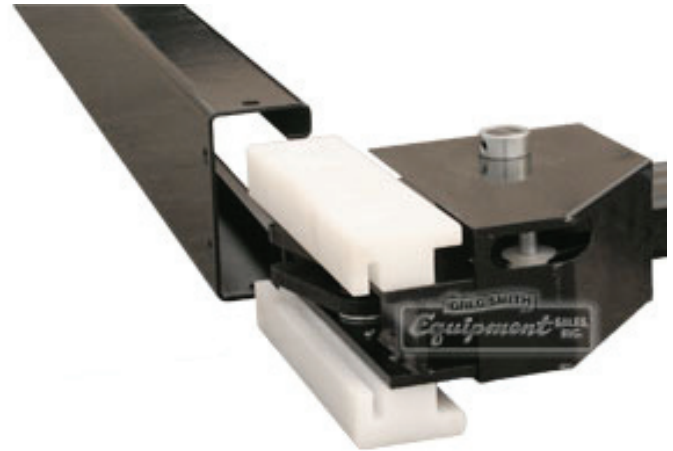

Line the sliding blocks on one end of the crossbeam to the inside of one column. Do the same for the other end of the crossbeam and then slide the crossbeam all the way to the bottom of both columns.

STEP 7:

*Click on each picture for a larger view.



Place one lock ladder near each column. With the threaded rod end of the lock ladders positioned at the TOP or opened end of the column.

STEP 8:



Insert a lock ladder into the center of the column and slide the lock ladder into the molded grooves on the inside of the slide blocks. (located in the cross tube).

(See next picture)

Repeat this process with the second lock ladder.

STEP 9:

*Click on each picture for a larger view.



Lock ladder is now positioned properly. Note how the metal lock ladder has been inserted into the grooves of the slide block.

Ultra-high Molecular Weight Polyethylene UHMWPE is an engineering plastic which is used extensively as the glide rails for industrial equipment and the low-friction socket in implanted hip joints.

STEP 10:



The top cap is attached to the top of the columns.

STEP 11:

*Click on each picture for a larger view.

Secure the top cap onto the columns with the 4 bolts.



Secure the top cap with the four bolts.

STEP 12:



Place the top cap on top of the column and make sure the cable hole in the top cap is directly over the pulley in the crossbeam. This hole is for the threaded end of the cable to be attached.

Insert the threaded portion lock ladder bolt through the lock ladder hole in top cap.

STEP 13:

*Click on each picture for a larger view.



Secure the threaded rod of the lock ladder with the washer and nut. Repeat this process for the top cap on the other column.

STEP 14:



This end of the lift is completed and is ready to be raised into position.

STEP 15:

*Click on each picture for a larger view.



Repeat steps 5-12 with the other two columns, crossbeam, lock ladders and hardware. When the two ends of the lift are finished, the crossbeams need to be positioned 14' 2 1/2" apart.

Check Figure #20 to make sure you have the power unit column in the correct position.

Make sure that the large cable pulleys in the crossbeams are facing each other. Two people, one at each column will raise the end of the crossbeam in the column until the crossbeam is resting (level) on the locking ladder's lowest position.

STEP 16:

This image shows underneath the runway with the cylinder.

Sealed end of cylinder
(This end of the runway should be next to the column with the power unit mounting bracket.)

Piston end of cylinder
(This end of the runway should be next to a column without a power unit mounting bracket)



If you have a large work area, and can spin the lift when finished, do not worry about the position of the power unit column.

If you are in a tight space....remember that the power unit must be on the power unit column.... only the left front or right rear.

See Figure #20

STEP 17:

*Click on each picture for a larger view.

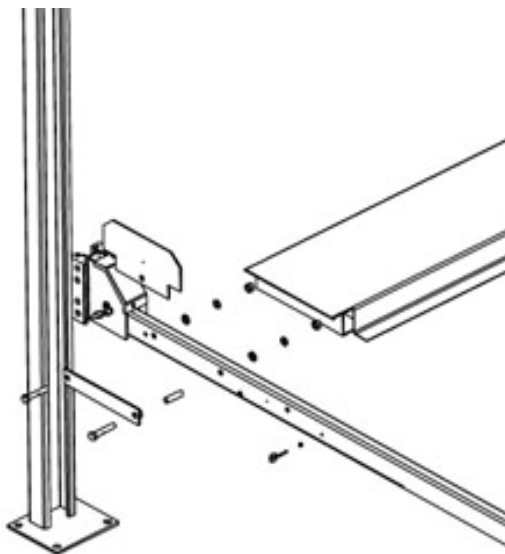

Placing the runways on the crossbeams will require two people, a cherry picker, or a fork truck.

The runways are very heavy.

Use caution when lifting.

Take the 18x100 bolts and run them through the stop plate bracket and through the cross tube on the runway. Making sure the spacers on the stop plate bracket are touching the cross tube.

STEP 18:



IMPORTANT

Before you place the runways on the crossbeams; **Make sure that the runway (with the cylinder) is on the same side as the column with the power unit mounting bracket. Only one column has the power unit mounting bracket. The open end of the cylinder (where the piston comes out) should be facing away from the column with the power unit mount.**

The sealed end of the cylinder should be facing toward the column with the power unit mount.

Attach the runways with the appropriate hardware and make sure that one of the spacer brackets is put at the end of each runway.

STEP 19:

*Click on each picture for a larger view.



The gap between the runway mounting bracket and the crossbeam is designed for easy removal and installation of the stop plates or approach ramps.

STEP 20:



Your lift should look like this.

REMEMBER....YOUR LIFT DOES NOT CARE ON WHICH END THE APPROACH RAMPS ARE POSITIONED. THEY WILL FIT AT EITHER END!

Your power unit column will always be on the same side as the cylinder runway.

That means that your power unit will be on the left front or the right rear column.

The lift in this picture will have the power unit on the right rear...but if you "spin" the lift with the help of the caster kit; the power unit will be on the left front. You really can't make a mistake here...if you think about it.

STEP 21:

*Click on each picture for a larger view.

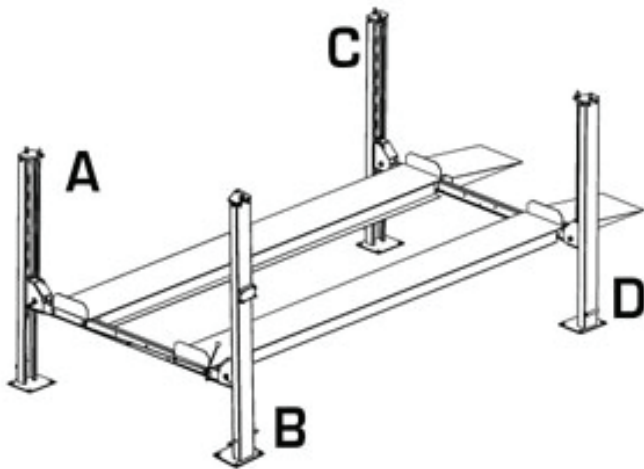

The lifts columns, cables, and pulleys are identified alphabetically to help you associate which column goes with which cable and pulley.

STEP 22:

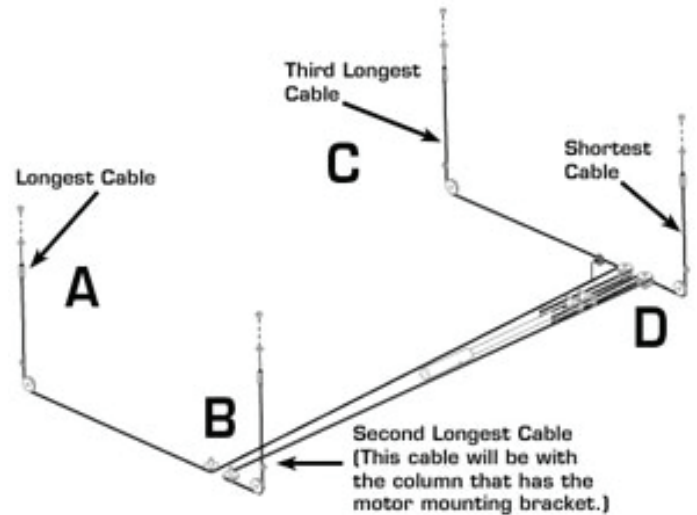

Identifying the cables by length will help speed up the process of routing the cables through the pulleys to the piston.

STEP 23:

*Click on each picture for a larger view.

The crimped ends of the cables are routed around the pulleys under the crossbeams and the master runway.

Then the crimped ends of the cables are secured into the block at the end of the piston of the lift cylinder.

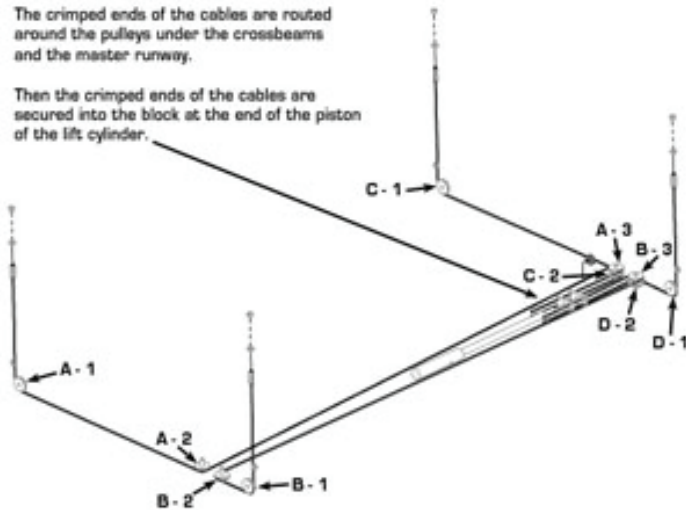

All cables are alphabetically associated with a pulley.

STEP 24:



Begin with the longest cable (**A**) and start routing the crimped end of the cable through the hole in the column (**A**) top cap.

STEP 25:

*Click on each picture for a larger view.



Route the cables down toward the crossbeam hole.

STEP 26:

Route the cable in front of this plastic pulley inside the crossbeam.

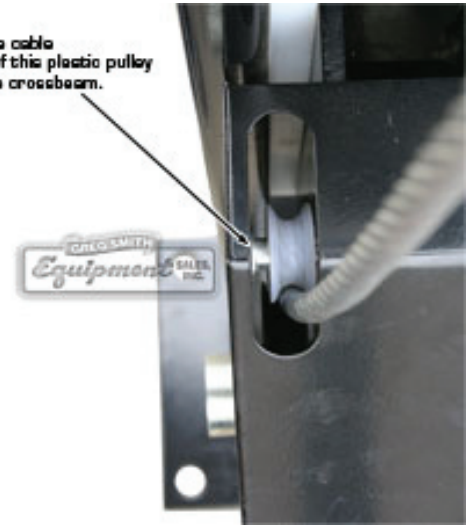

Route the cable to the crossbeam; and thread the cable to the outside (away from the column) of the plastic pulley and down into the crossbeam.

STEP 27:

*Click on each picture for a larger view.

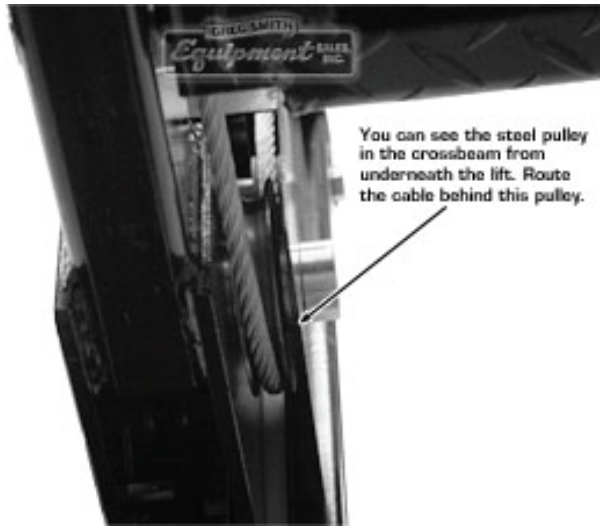

Route the crimped end of the cable behind the steel pulley on the bottom of the crossbeam.

Repeat steps 20-23 with the other three cables starting with the second longest cable **(B)** and finishing with the shortest cable **(D)**.

STEP 28:

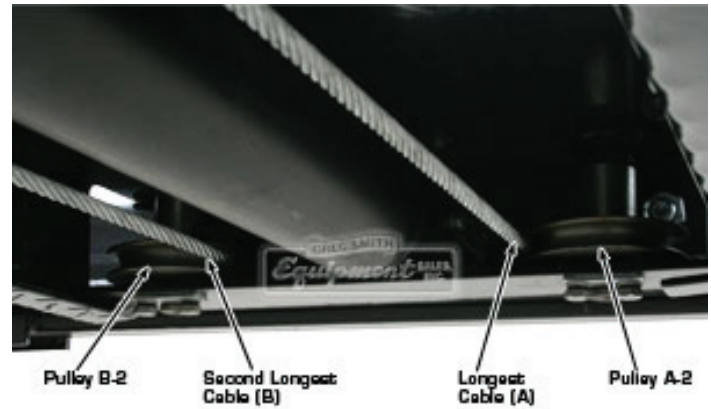

The pulley system is located under the cylinder runway.

Route all cables around their respective pulleys.

STEP 29:

*Click on each picture for a larger view.

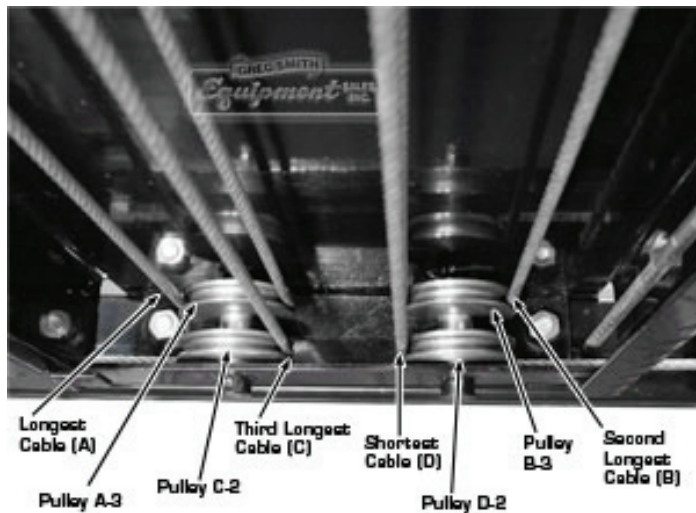

Pulleys are located at the end of the cylinder run-way next to the column **WITHOUT** the power unit bracket.

The two longer cables go around the top pulleys (nearest to their columns).

The shorter cables go around the bottom pulleys (nearest to their columns).

STEP 30:



The crimped ends of the cables go through the four holes of the plate on the piston end of the cylinder.

See picture below.

STEP 31:

*Click on each picture for a larger view.

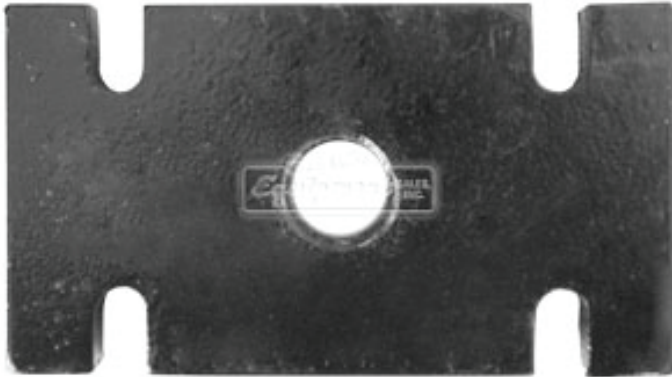

This is the plate at the end of the piston where the crimped ends of the cables will be attached.

STEP 32:



Crimped end of lift cable

Make sure all four cable ends are secured (into the plate) on the piston before proceeding.

STEP 33:

*Click on each picture for a larger view.



This is a two person job.

Attach the power unit using the four bolts and nuts provided.

STEP 34:



After the power unit has been securely mounted to the bracket attach the hydraulic hose to the power unit.

See Figure #35

STEP 35:

*Click on each picture for a larger view.

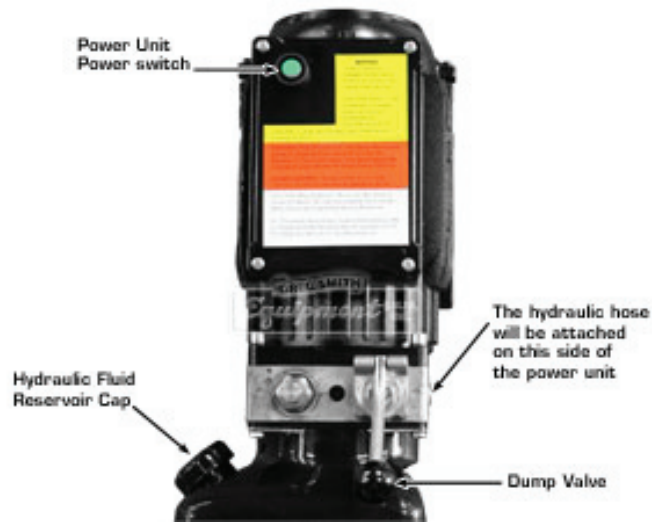

STEP 36:



Attach the end of the hydraulic line with the 90 degree fitting to the power unit. Use caution when tightening.

STEP 37:

*Click on each picture for a larger view.



Attach the straight end of the hydraulic line to the fitting on the runway. Use caution when tightening.

STEP 38:



Remove hydraulic fluid reservoir cap and fill with approximately 3 gallons of medium viscosity (AW 32 or AW 46) hydraulic fluid.

STEP 39:

*Click on each picture for a larger view.

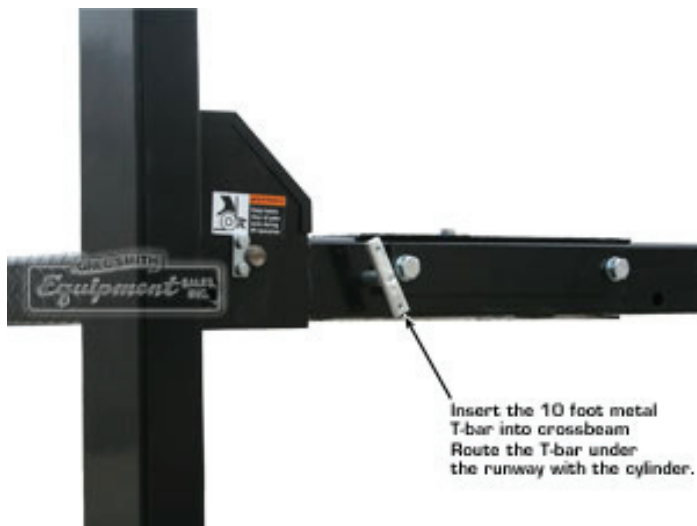

Insert the 10 foot long metal T bar under the length of the cylinder runway. Start at the end of the runway NOT attached to the power unit column.

It is very important to leave plenty of room to insert this part of the lock assembly.

The rod is 10 feet long.

STEP 40:



On the same end of the lift, the end away from the power unit, adjust the short section of the lock rod to line up with the lock release at the end of the crossbeam.

(See picture below)

STEP 41:

*Click on each picture for a larger view.



Secure the lock rod to the lock release using the 10 mm nut provided.

STEP 42:

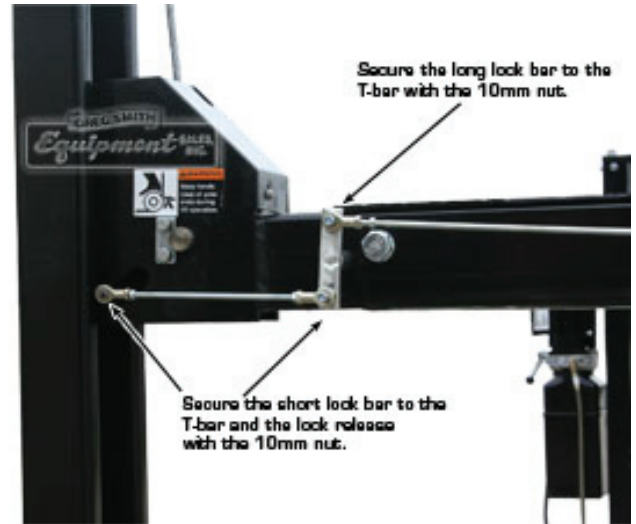

Repeat steps 40 and 41 with the long section of the lock rod.

STEP 43:

*Click on each picture for a larger view.

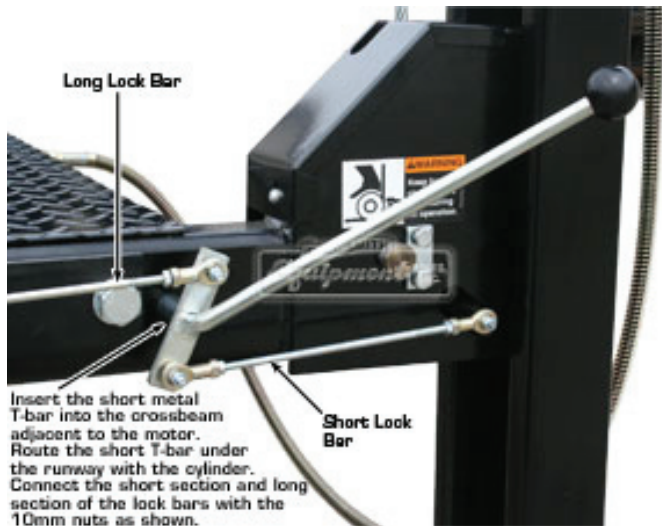

At the other end of the lift (nearest the power unit column) insert the short T bar (to which the lock release handle is attached) Install the short section and long section of lock rods using the 10 mm. nuts provided.

STEP 44:



Plug your lift into a 110 volt (20 amps) outlet using a heavy duty GROUNDED extension cord.

Make sure the lift is on a concrete level surface and all column bases are contacting the floor.

Keep everyone clear of the lift runways.

Press the power button and raise the runways to shoulder height.

STEP 45:

*Click on each picture for a larger view.

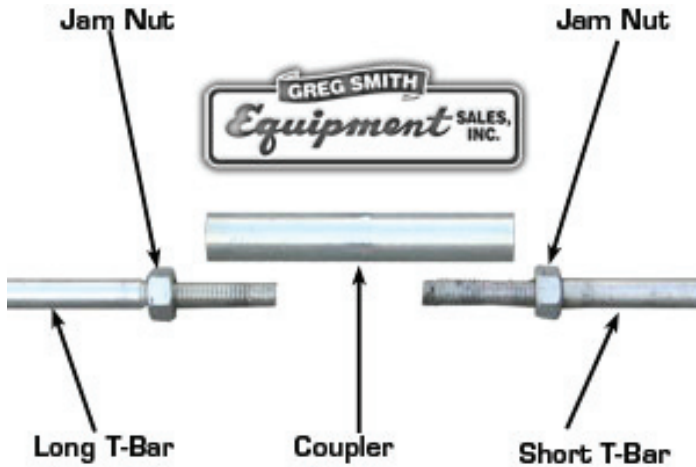

Under the cylinder runway, place the jam nuts on the long and short T bar sections of the lock assembly. Make sure an even amount of threads are showing on each piece.

STEP 46:



Connect the two T bars with the coupler.

STEP 47:

*Click on each picture for a larger view.



To level (front to back AND side to side) the lift you will need to adjust the lock ladders and the lift cables.

The adjustments are made by turning the nut/screw combinations located on the top of each of the columns.

Begin the procedure by adjusting (leveling) the lock ladders. Once the lock ladders are leveled, then the cables will be leveled.

STEP 48:

*Click on each picture for a larger view.

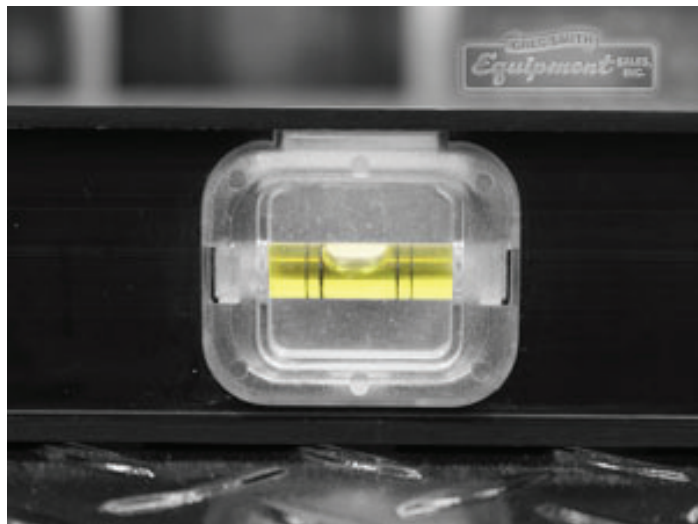

To level the lock ladders of the lift, lower the runways to approximately a waist high position. Make sure that the runways are resting on the lock ladders. Depress the dump valve (Figure #35) which allows the hydraulic oil in the cylinder to flow back into the power unit's reservoir. The runways will then lower to the next locking position on the lock ladder. The locks will automatically engage.

THERE ARE MANY WAYS TO "LEVEL" YOUR NEW LIFT.

WE HAVE OUTLINED BELOW ONE OF THE EASIEST METHODS. Hope it helps!

You want to determine which column has its lock ladder in the highest position. Place your four foot level (minimum level length) in the middle of the right runway. (there is no left nor right runway, but for the purpose of this leveling guide, stand at the approach ramp end of your lift, and the runway on your right... will be the right runway)

The level bubble will determine which.

STEP 49:

*Click on each picture for a larger view.

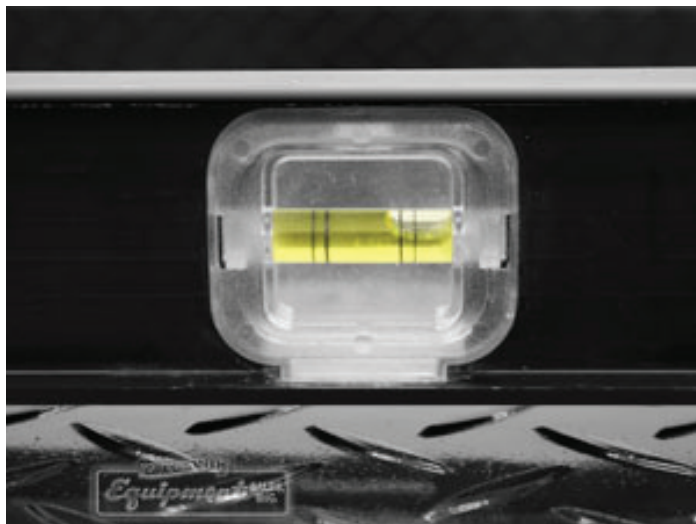

If the bubble is outside the line to the right (toward the front column), the right front column ladder locks are in the higher position. We will assume that this is the case.

Now place the level on the runways at the front of the lift. If the bubble is in the middle, both left and right front columns have lock ladders at a level position.

Let us assume that the bubble moves toward the right (outside the lines).

This means that that the right front column has the highest lock position of all four columns. We will use this column as a benchmark.

Carefully tighten the lock ladder nut on the top of the right front column until the inserted plastic lock is engaged. (held securely)

Adjust all other lock ladders (in the other three columns) to be "level" with the right front lock ladder position.

Next, the cables need to be adjusted to a level position. Raise the runways off their locked position (about 2 inches).

Repeat the same "leveling" process as was done for the lock ladders. Adjust the cable adjustment nut to obtain level runway positions.

STEP 50:

*Click on each picture for a larger view.



Tighten all eight nuts (two on each of the column tops).

Lower the runways to the ground...you must hold the lock release lever and the dump valve at the same time to make sure all locks are disengaged when lowering.

When the runways are on the ground, press the start button and raise the runways. If you have adjusted the lock ladders and cables correctly, then all four locks should engage at about the same time. You can listen to the lock sounds in each column and determine if additional adjustments are needed.

STEP 51:



Align the two prongs at the end of the castor away from the wheel with the holes in the tube on the back side of the column.

To attach the castor kit, position each castor assembly so that the two metal arms (with holes near the end) line up with the tube welded near the base of the column.

STEP 52:

*Click on each picture for a larger view.



Insert the silver pin
through arms and tubes.
Attach cotter key.

Insert the silver pin through arms and tubes.

Attach cotter key.

STEP 53:



Weight of runways on
caster kit extensions
will lift all four columns
(less than 1") off the floor.
The lift will then roll easily
on the four steel casters.

Lower lift and pressure of casters on surface will raise columns (less than 1/2 inch) off surface to allow lift to be easily moved on a solid concrete surface.

STEP 54:

*Click on each picture for a larger view.

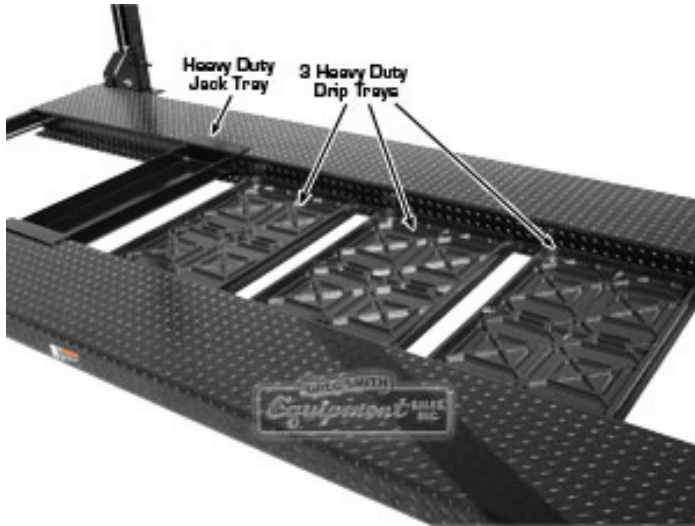

Lift comes standard with three drip trays and heavy duty jack tray.

STEP 55:



Runway approach ramps are inserted between the runway mounting bracket and the crossbeam. They are easily removed and can be stored between the runways.

STEP 56:

*Click on each picture for a larger view.

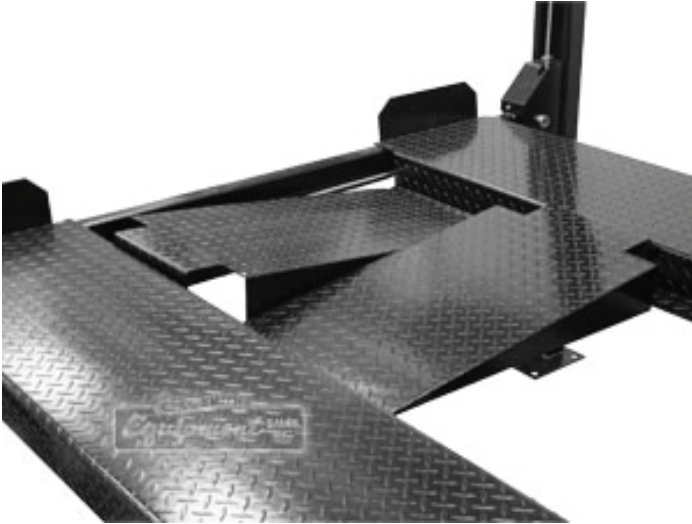

Ramps can be placed in between the runways when not in use.

STEP 57:

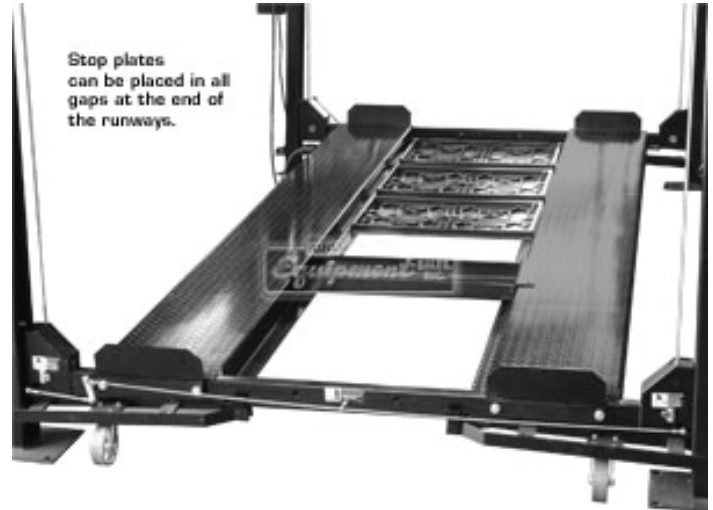

Approach ramps can be placed at either end.

After the lift is in the air, approach ramps can be removed and stop plates can be inserted at the end of both runways.

Note: Caster Kit is installed and ready to be engaged.

STEP 58:

*Click on each picture for a larger view.



The Direct Lift with the caster kit attached.

STEP 59:



These are REAL photos of real cars. You can use your Direct Lift with confidence for many years!