



COMPANY WITH QUALITY MANAGEMENT  
SYSTEM CERTIFIED BY DNV  
= ISO 9001:2008 =

ATLAS  
MC-FL12000



 MOTOR: 3 ph. - 230/400V - 50Hz - 3,5 kW

## MC-FL12000 FORK LIFT

Versione speciale per carrelli elevatori.  
Portata 5.500Kg per colonna, per interno.

*Special version for fork lifts.  
5.500Kg capacity per column, for indoor use.*

Sonderversion für Gabelstapler.  
Tragfähigkeit 5.500 kg je Säule, in Werkstatthallen.

*Version spéciale pour chariots élévateurs.  
Capacité 5.500 kg par colonne, pour intérieur.*

Versión especial para carretillas.  
Capacidad 5.500 kg por columna, para interior.

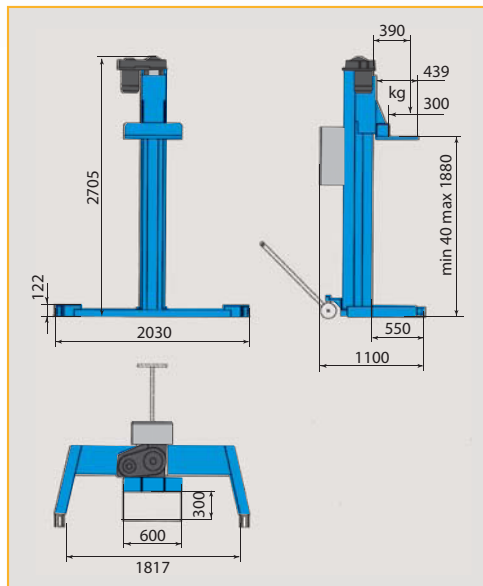

### INDIANA

5800 Massachusetts Avenue  
Indianapolis, IN 46218  
Tel. 800.262.1950  
Fax. 317.542.1448  
sales@gregsmithequipment.com

### DELAWARE

250 Executive Drive, Ste 1  
Newark, DE 19702  
Tel. 800.715.1950  
Fax. 302.894.9136

### GEORGIA

5405 Buford Hwy N.E., Ste 160  
Norcross, GA 30071  
Tel. 800.768.4104  
Fax. 678.781.0149

### ARIZONA

8399 West Van Buren St, Ste 210  
Tolleson, AZ 85353  
Tel. 800.602.9928  
Fax. 602.490.3495

### FLORIDA

12250 NW 25th St, Ste 112  
Miami, FL 33182  
Tel. 800.305.5609  
Fax. 305.722.3804

### NEW HAMPSHIRE

8 Industrial Drive  
Hudson, NH 03051  
Tel. 800.360.0053  
Fax. 603.718.1589

Le caratteristiche tecniche e gli allestimenti presentati in questo prospetto possono subire variazioni. Le immagini riprodotte non sono vincolanti.

*Technical data and composition presented in this catalogue may vary. Pictures reproduced are only indicative.*

Die techn. Daten und die Ausrüstungen, die in diesem Prospekt enthalten sind, können Änderungen erfahren. Deshalb sind die Abbildungen unverbindlich.

*Les caractéristiques techniques et les compositions présentées dans ce prospectus peuvent subir des variations. Les images reproduites n'ont qu'une valeur indicative.*

Las características técnicas y las composiciones ilustradas en este folleto pueden sufrir variaciones. Las imágenes propuestas son solamente indicativas.

