



# ATLAS BP8000/BP9000 8,000 lb./9,000 lb. Capacity Two-Post Baseplate Lift

## INSTALLATION & OPERATION MANUAL



**BP8000**



**BP9000**

### **INDIANA**

5800 MASSACHUSETTS AVE.  
INDIANAPOLIS, IN 46218

PHONE: (800) 262-1950  
FAX: (317) 542-1448

### **DELAWARE**

250 EXECUTIVE DRIVE, SUITE 1  
NEWARK, DE 19702

PHONE: (800) 715-1950  
FAX: (302) 894-9136

### **GEORGIA**

2375 BUTTON GWINNETT DR., SUITE 100  
ATLANTA, GA 30340

PHONE: (800) 768-4104  
FAX: (678) 781-0149

### **ARIZONA**

8399 W VAN BUREN ST., SUITE 210  
TOLLESON, AZ 85353

PHONE: (800) 602-9928  
FAX: (602) 490-3495

### **NEW HAMPSHIRE**

8 INDUSTRIAL DRIVE  
HUDSON, NH 03051

PHONE: (800) 360-0053

### **FLORIDA**

11801 NW 100th RD., SUITE 8  
MEDLEY, FL 33178

PHONE: (800) 305-5609

### **TEXAS**

3206 INDUSTRIAL TERRACE, SUITE 102  
AUSTIN, TX 78758

PHONE: (800) 512-7611

# CONTENTS

Product Features and Specifications .....	1
Installation Requirement .....	4
Steps of Installation .....	5
Exploded View .....	19
Test Run .....	23
Operation Instruction .....	26
Maintenance .....	26
Trouble Shooting .....	27
Parts List.....	28

# I. PRODUCT FEATURES AND SPECIFICATIONS

## FLOOR PLATE CHAIN-DRIVE MODEL FEATURES

Model BP8000 (See Fig. 1)

- Compact design
- Dual hydraulic cylinders, designed and made on ANSI standards, utilizing NOK oil seal for cylinder
- Self- lubricating UHMW Polyethylene sliders and bronze bush
- Single-point safety release and dual safety design

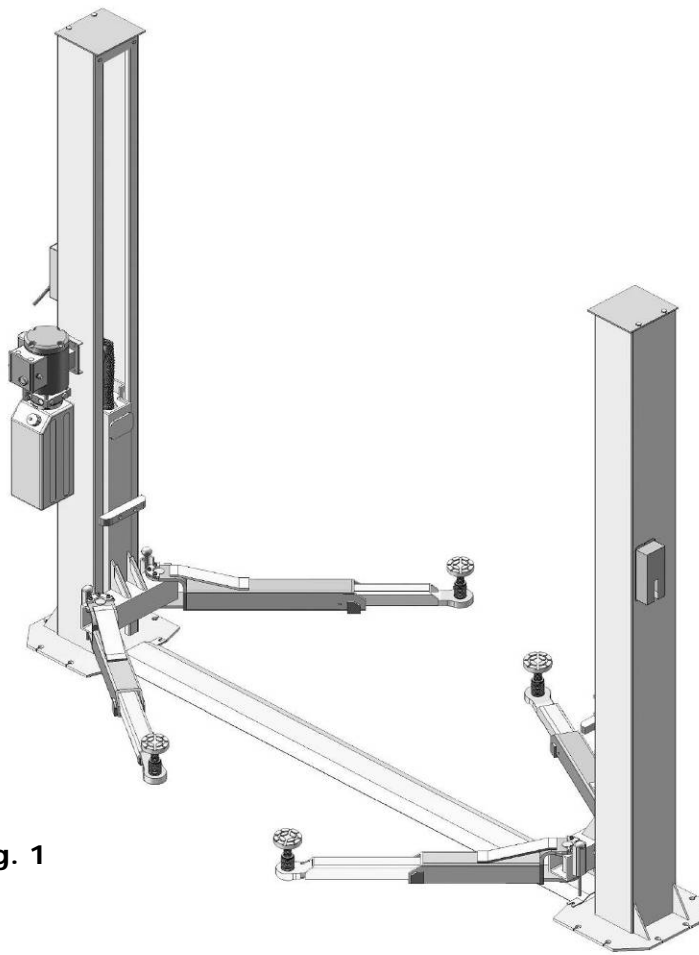

Fig. 1

## MODEL BP8000 SPECIFICATIONS

Model	Style	Lifting Capacity	Lifting Time	Lifting Height	Overall Height	Overall Width	Width Between Posts	Minimum Pad Height for screw adapters	Minimum Pad Height for stackable adapter	Motor
BP8000	Floor plate Chain-drive	4.0 T 9,000 lbs	45 Sec	1825-1905 mm 72" – 75"	2738 mm 107 3/4"	3350 mm 132"	2780 mm 109 1/2"	100 mm 4"	80 mm 3 1/8"	2.0/3.0 HP

## FLOOR PLATE CHAIN-DRIVE TWO POST LIFT

### Model BP9000 (See Fig. 2)

- Compact design
- Dual hydraulic cylinders, designed and made on ANSI standards, utilizing NOK oil seal for cylinder
- Self- lubricating UHMW Polyethylene sliders and bronze bush
- Single-point safety release and dual safety design
- Super-Symmetric (2 in 1) arms design, Stackable adapters 1.5", 3", 6" as standard

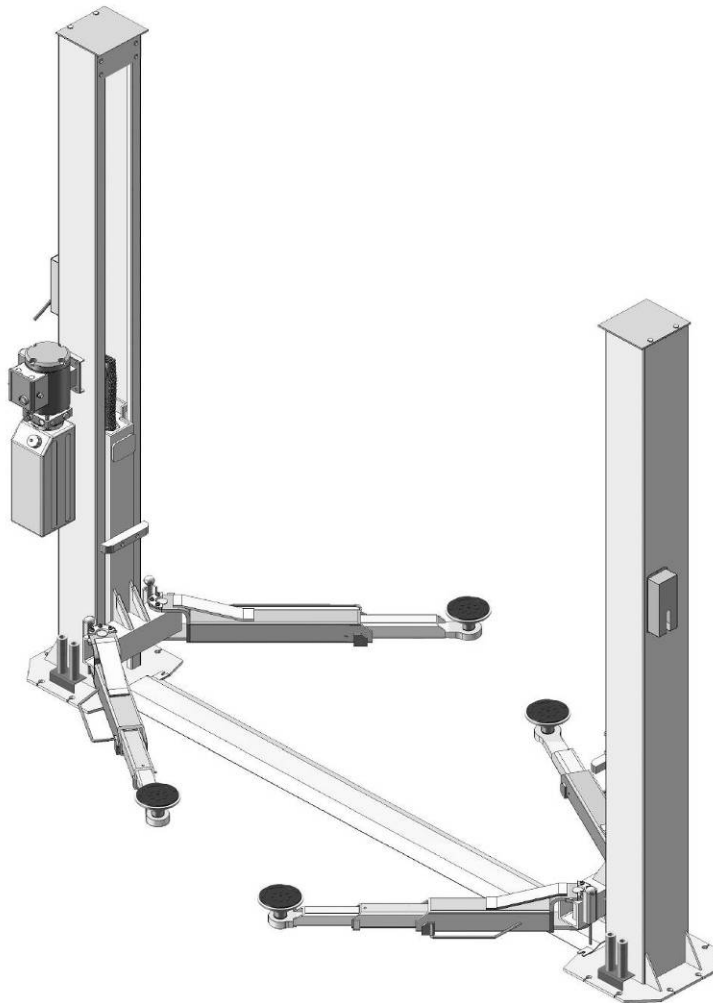

Fig. 2

### MODEL BP9000 SPECIFICATIONS

Model	Style	Lifting Capacity	Lifting Time	Lifting Height	Overall Height	Overall Width	Width Between Posts	Minimum Pad Height for stackable adapter	Minimum Pad Height for screw adapters	Motor
BP9000	Floor plate Chain-drive	4.0 T 9,000 lbs	49 S	1930-2200 mm 76" – 86 5/8"	2837 mm 111 3/4"	3458 mm 136 1/8"	2850 mm 112 1/4"	105 mm 3 1/8"	100 mm 4"	2.0/3.0 HP

## Arm Swings View

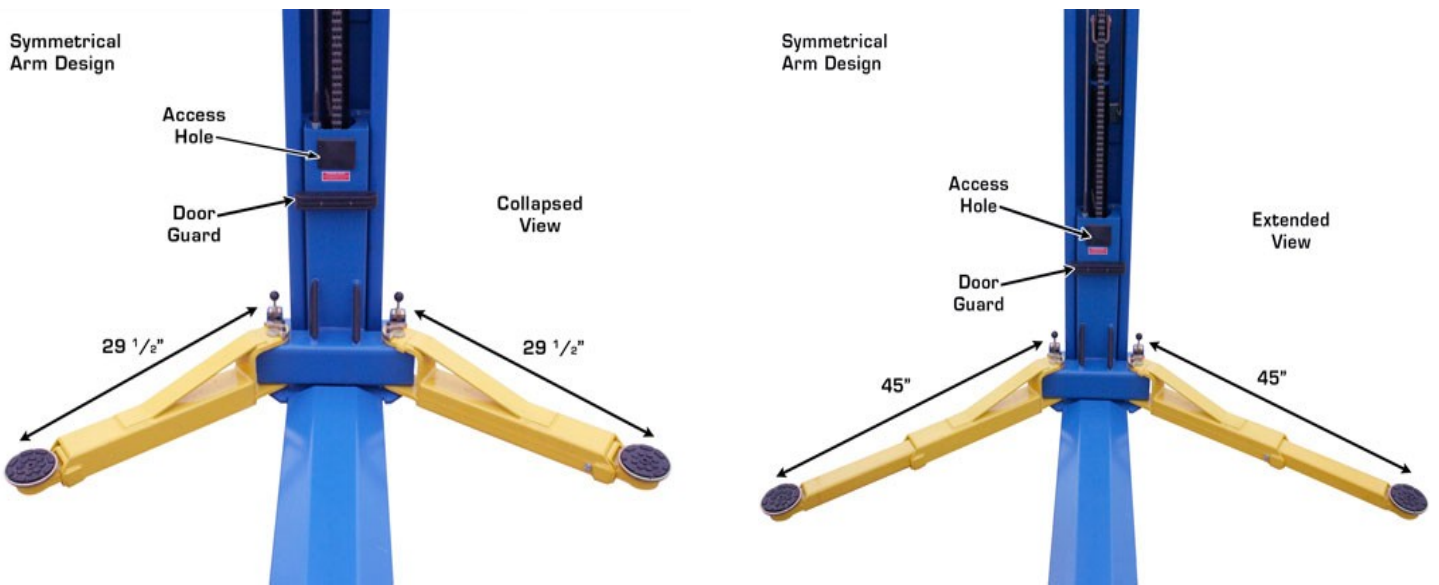

Fig. 3

## Model BP8000

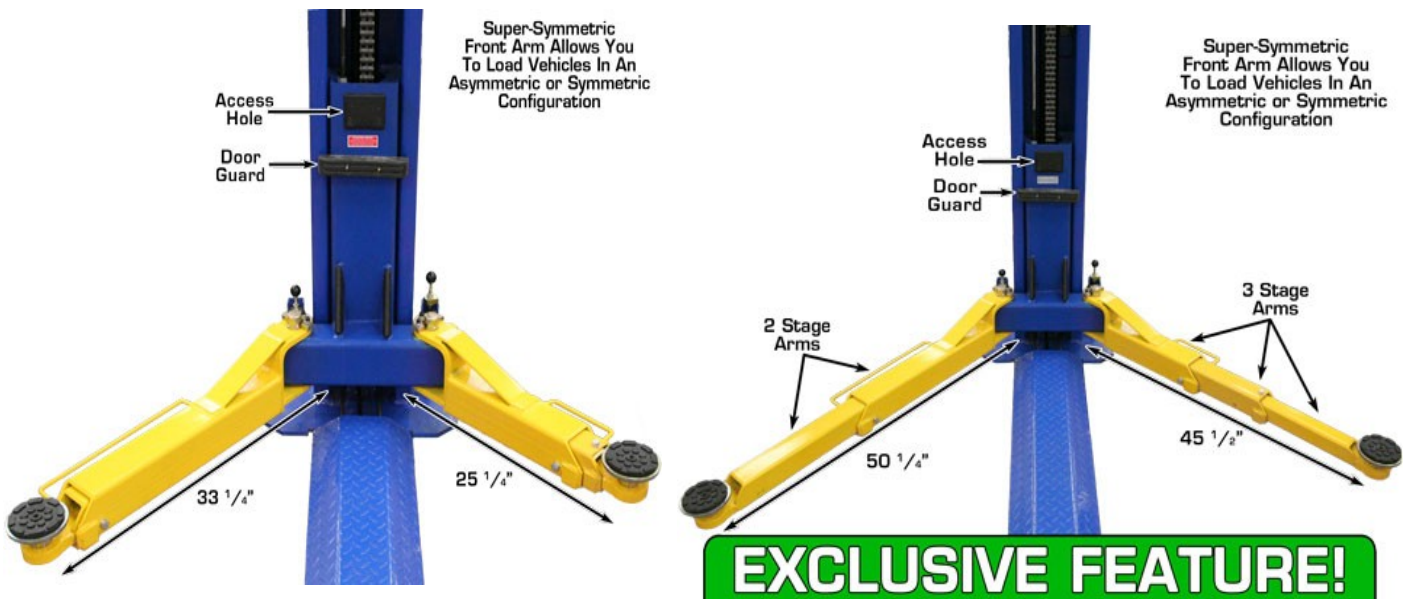

Fig. 4

## Model BP9000

## □. INSTALLATION REQUIREMENT

### A. TOOLS REQUIRED

- ✓ Rotary Hammer Drill (19mm/3/4")



- ✓ Hammer



- ✓ 4 Foot Level



- ✓ Crescent Wrench (12mm)



- ✓ Ratchet With Socket (30mm)



- ✓ Metric Wrench set

(10#, 13#, 14#, 15#, 17#, 19#, 24#, 27#)



- ✓ Carpenter's Chalk



- ✓ Screw Drivers



- ✓ Tape Measure (25 Foot)



- ✓ Pliers



- ✓ Allen Head Wrench (6#)



- ✓ Vise Grips



Fig. 5

**B. Concrete Specifications(See Fig. 6).**

**Concrete must be in compliance to the specifications below.**

**Failure To Do So May Result In Personal Injury or Property Damage.**

1. Concrete must have a thickness of 4 inches minimum and without reinforcing steel bars, and must be completely cured before the lift installation.
2. Concrete must be in good condition and must have a test strength 3,500 psi (250kg/cm<sup>2</sup>) minimum.
3. Floors must be level and no cracks.

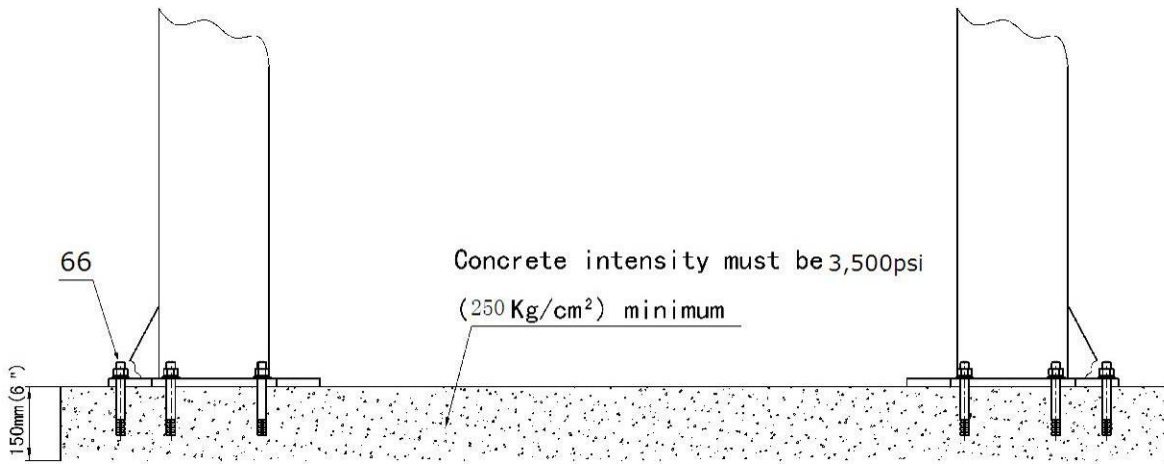

**Fig. 6**

**C. POWER SUPPLY**

*The capacity of power must be 3 HP minimum. The electrical wire must be a minimum of 10 gauge.*

**III. INSTALLATION PROCEDURES**

**A. Location of the Installation**

Check the installation location (concrete, layout, space size etc.) so it is suitable for lift installation.

**B. Use a carpenter's chalk line to establish installation layout of the base plate (See Fig. 7-8).**

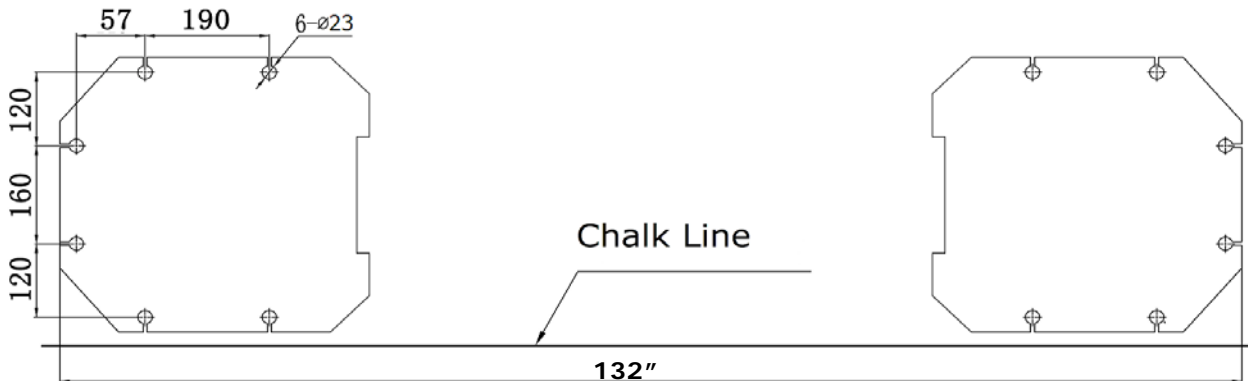

**Fig. 7 Model BP8000**

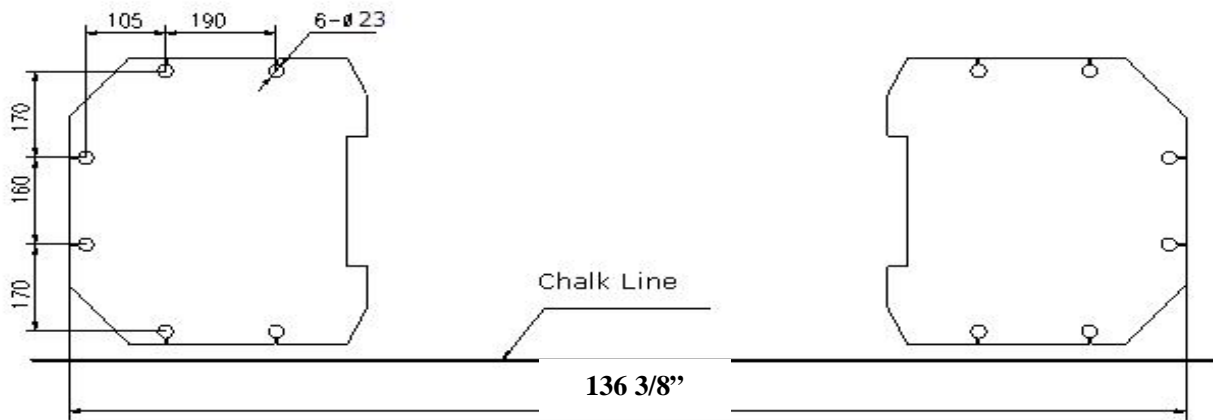

**Fig. 8 Model BP9000**

**C. Check the Parts Before Assembly.**

1. Packaged lift and Hydraulic Power Unit (See Fig. 9).



**Fig. 9**

2. Move aside the lift with fork lift or hoist, and open the outer packing carefully (See Fig. 10).

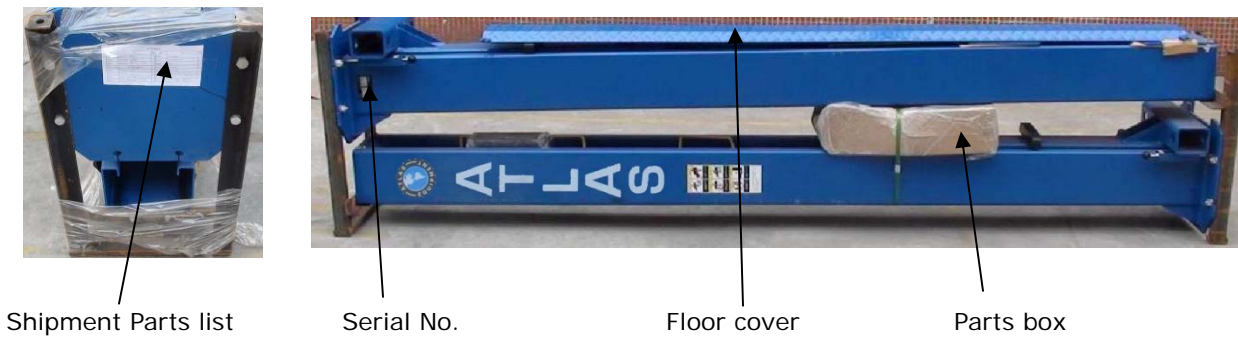

**Fig. 10**



3. Take out the parts from upper and inside of the column, then take out the parts box, and check the parts according to the shipment parts list (See Fig. 11 & Fig. 12). **WARNING: Truck Adapters are located inside of the columns.**



Fig. 11 Model BP8000

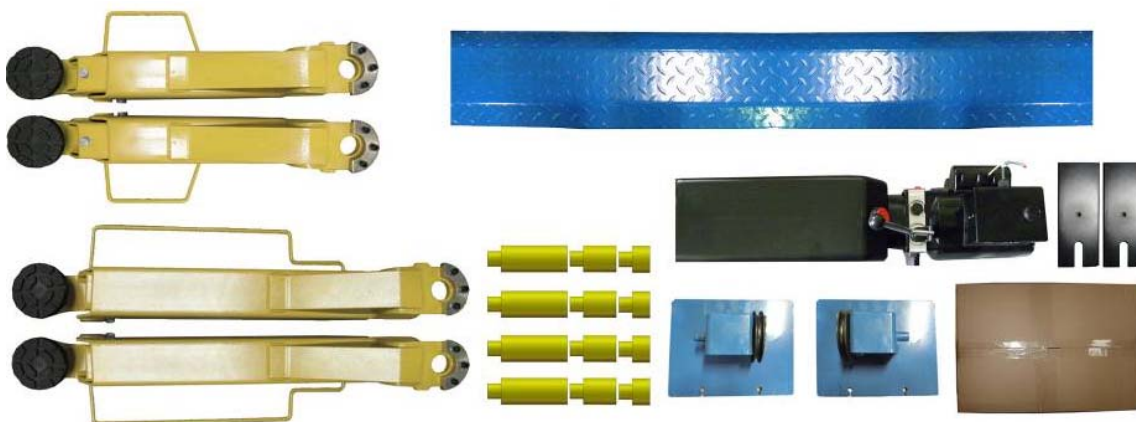

Fig. 12 Model BP9000

4. Loosen the screws on the upper package stand, take off the upper column and remove the package stand (See Fig. 13).



Fig. 13

5. Open the parts box and check the parts according to parts box list  
(See Fig. 14 & Fig.15).

**Model BP8000**  
**Fig. 14**



**Model BP9000**  
**Fig. 15**



6. Check the parts bag according to parts bag list (See Fig. 16 & Fig.17).



**Model BP8000**  
**Fig. 16**



**Model BP9000**  
**Fig. 17**



**D. Position Power side Post**

Lay down two posts on the installation site parallel, position the Power side post according to the actual installation environment.

(See Fig. 18 & Fig. 19).

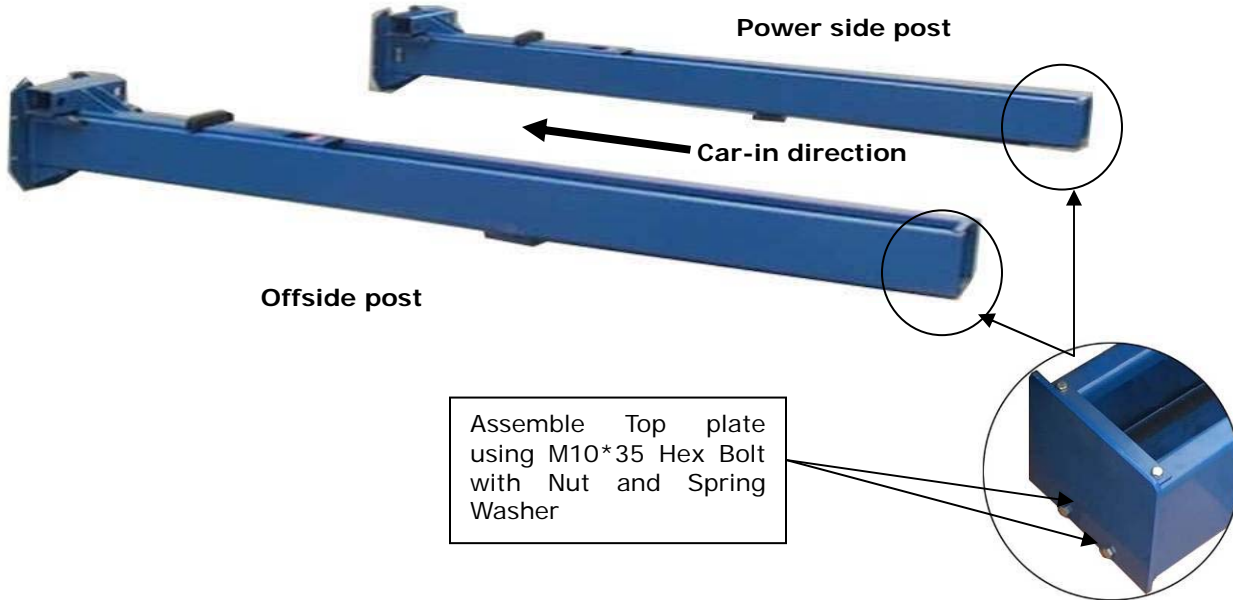

**Fig. 18 Model BP8000**

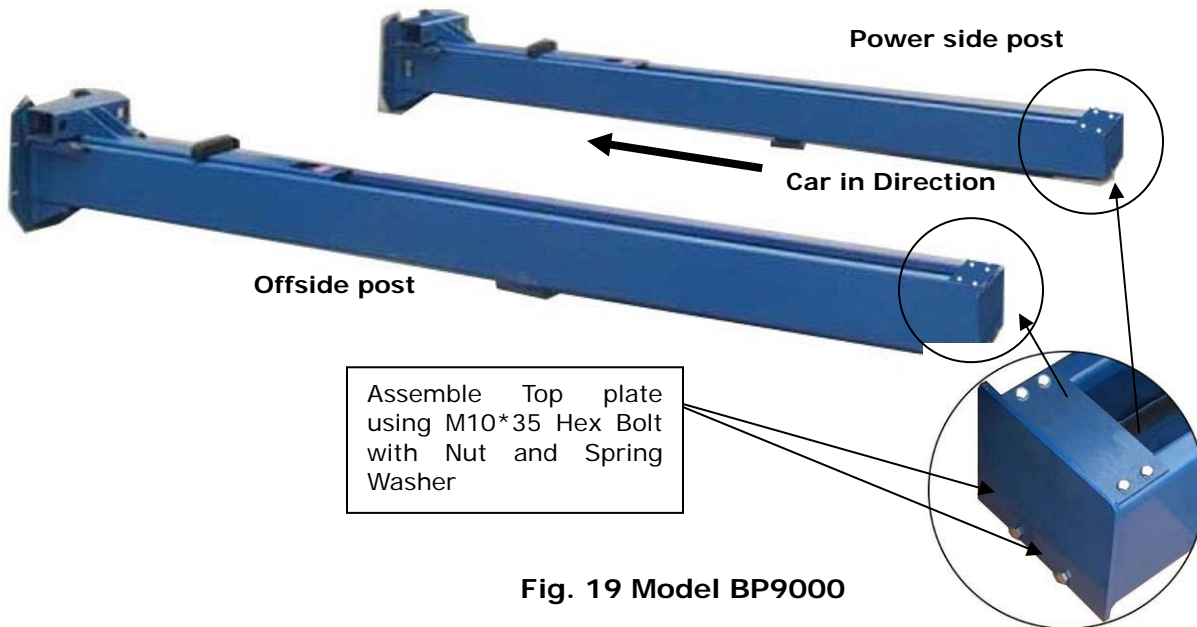

**Fig. 19 Model BP9000**

## E. Cable Routing

1. Push the carriages higher than chain pulley (See Fig. 20).

Push the carriages higher than chain pulley, cable pass through the top of the carriages and pass through the hole of the bottom steel plate of the carriages

Pull out cable

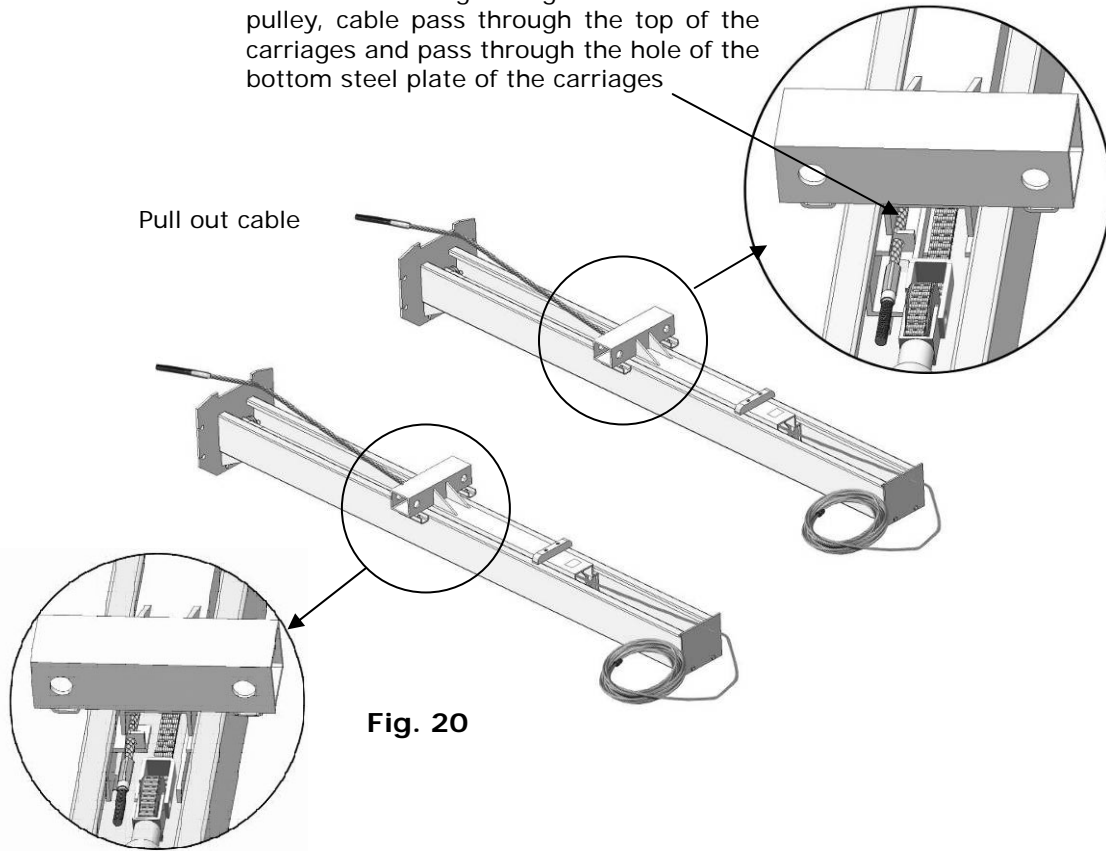

Fig. 20

2. Push the carriages to the bottom of the columns. (See Fig. 21)



Fig. 21

## F. Position posts (See Fig. 22)

Check the posts plumb with level bar, and adjusting with the shims if the columns are not vertical.

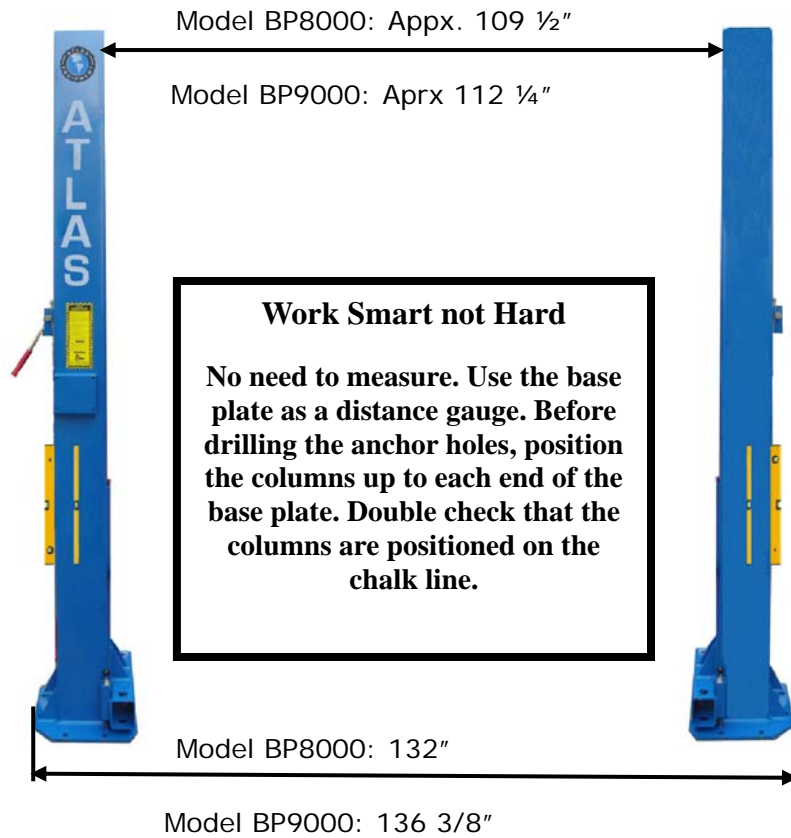
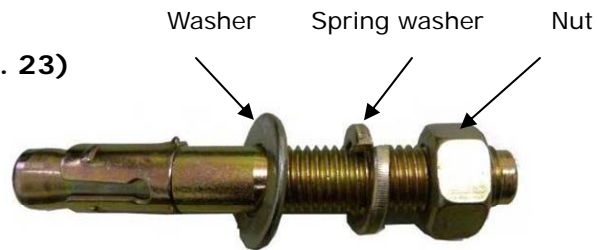

Fig. 22

## G. Fix Anchor Bolts

1. Prepare the anchor bolts. (See Fig. 23)

Fig. 23



2. Use a hammer drill with a 3/4" (19mm) masonry bit and drill all the anchor holes. Install the anchor bolts with a hammer. Tighten the Anchor Bolts between 85 and 110 foot pounds (See Fig. 24).

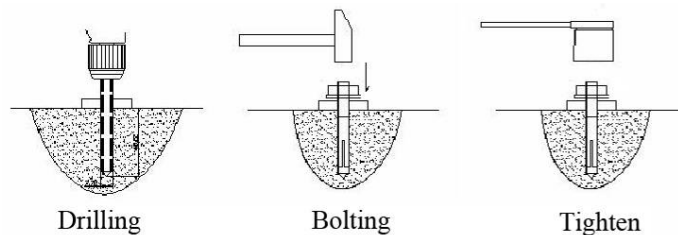

Fig. 24

H. Lift the carriages up by hand and rest them on the first set of locks  
(See Fig. 25).

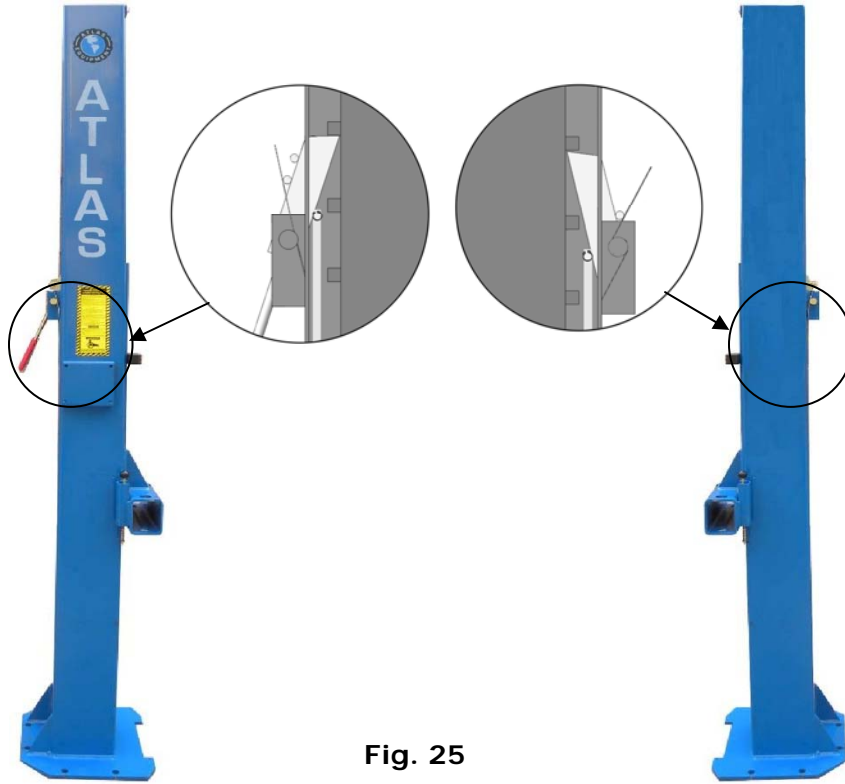
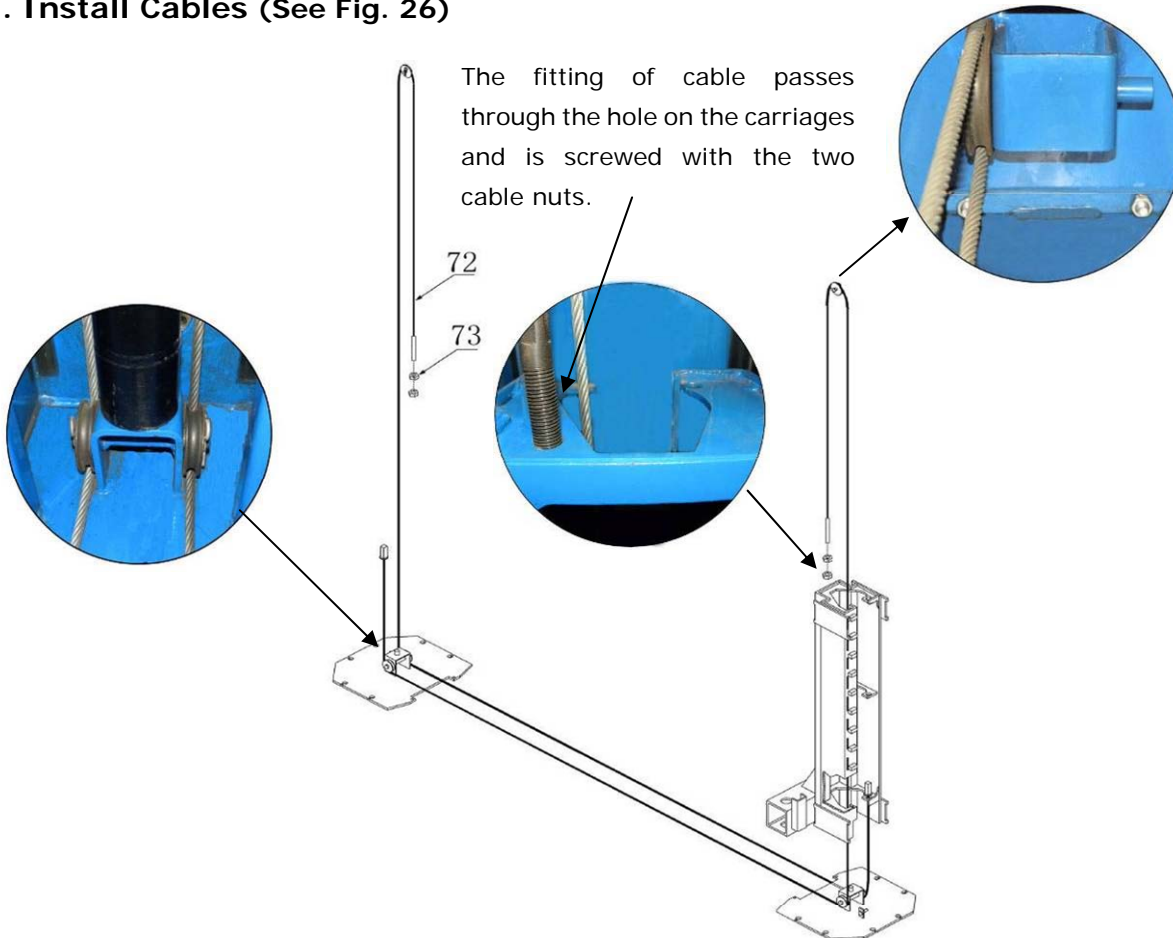
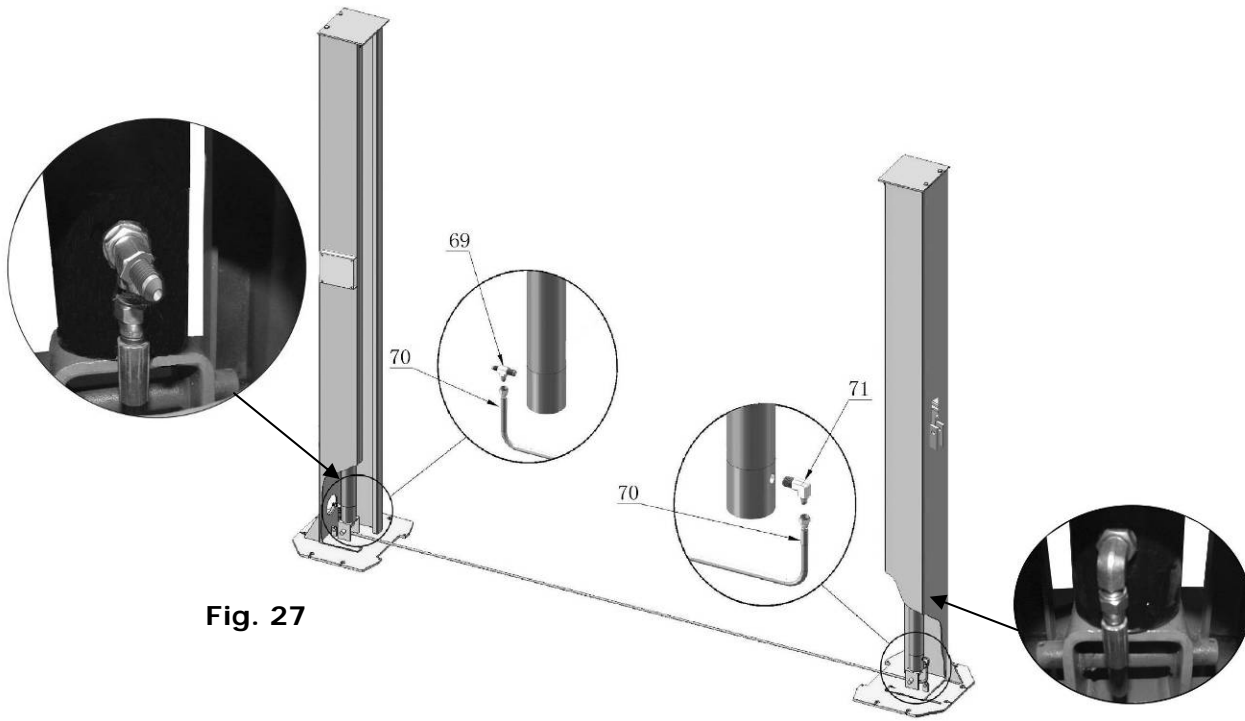

Fig. 25

I. Install Cables (See Fig. 26)



**J. Oil Hose Assembly (See Fig. 27).**

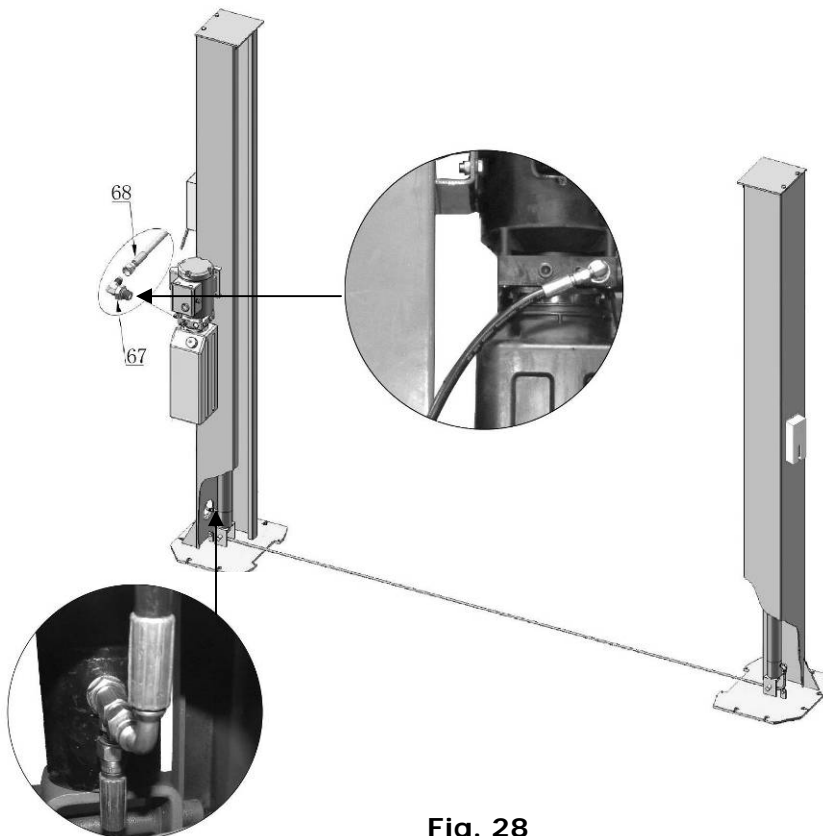

**Fig. 27**

**K. Install Hydraulic Power Unit and Oil Hose Assembly (See Fig. 28).**

Tighten all the hydraulic fittings, and fill the reservoir with hydraulic oil (Appx. 3 gallons)

**Note: Use AW32 or AW46 series hydraulic oil**

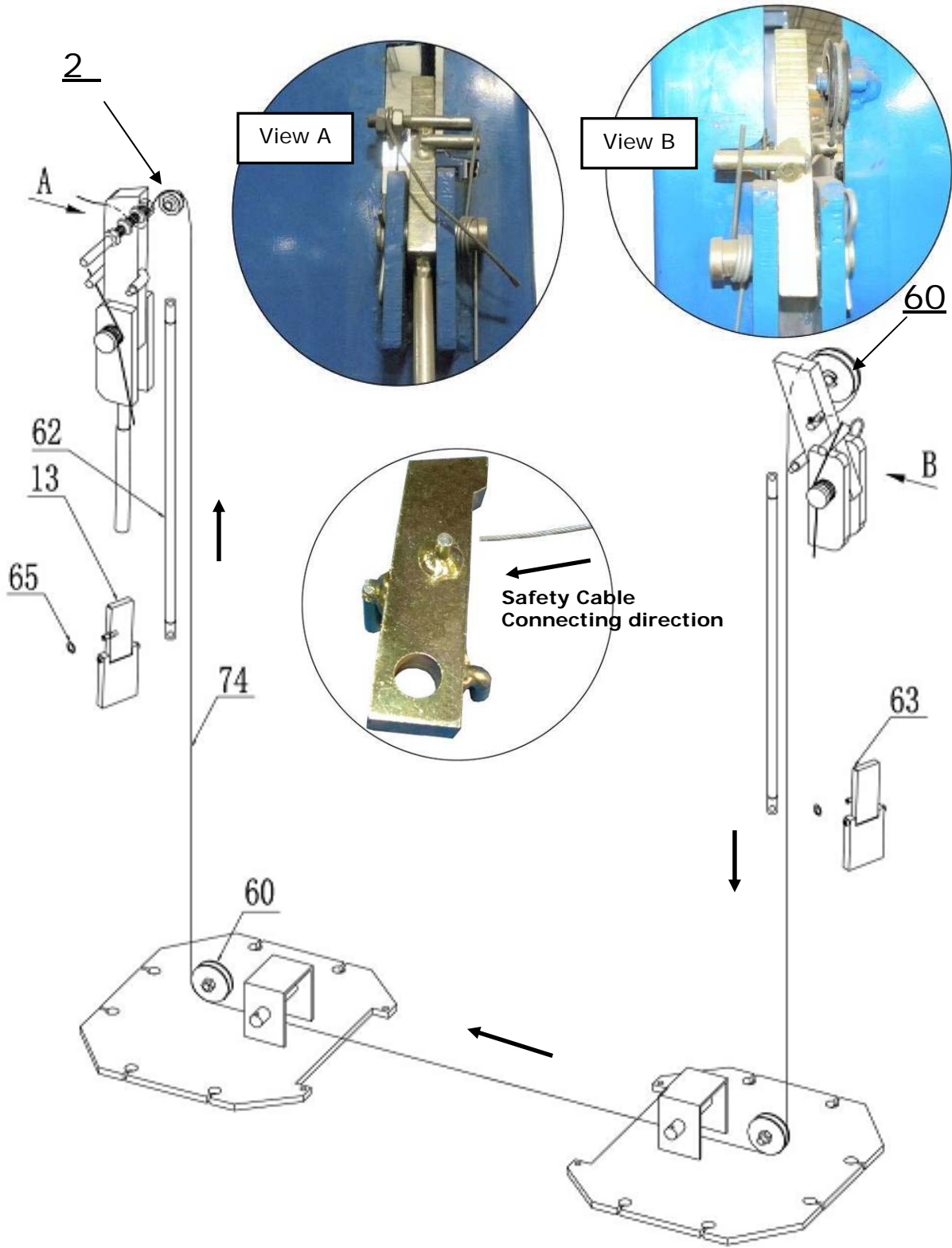

**Fig. 28**

**L. Install Safety Device and Safety Cable (See Fig. 29).**

**NOTE:** 1. Assemble Safety Cable from Offside Safety Assembly.

2. Pay close attention to the connecting direction of the Safety Cable.



**Fig. 29**



**M. Assemble the Protective Rubber Sets (See Fig. 30).**



**Fig. 30**

**N. Install Lifting Arms and Adjust the Arm Locks**

1. Install the Lifting Arms (See Fig. 31 & Fig. 32)

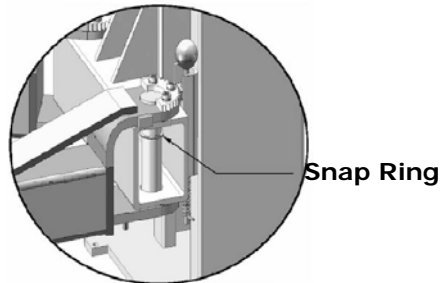

**Model 209  
Fig. 31**

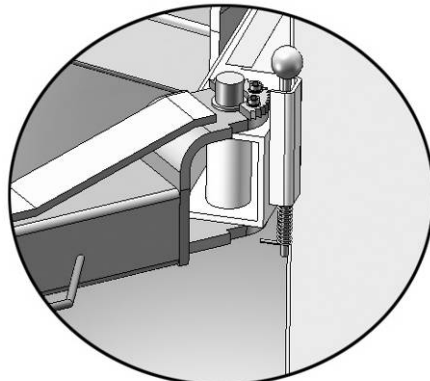

**Model 209X  
Fig. 32**

2. Lower the carriages down to the lowest position, then use the 17mm Wrench to loosen the nut (See Fig. 33)

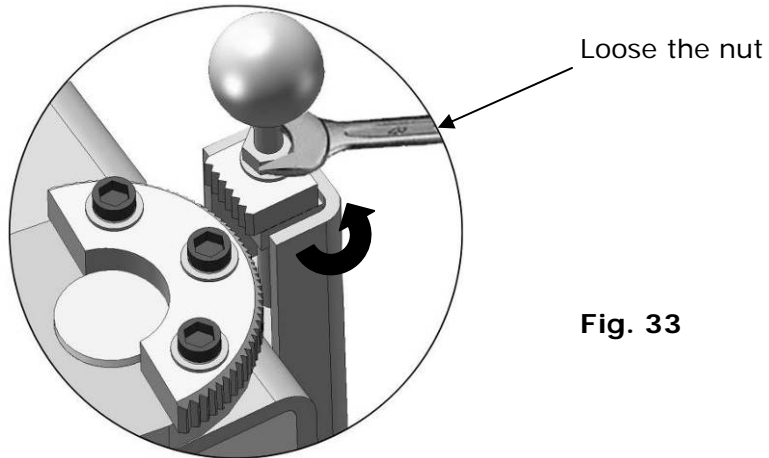

Fig. 33

3. Adjust the arm lock. Follow the arrow direction (See Fig. 34).

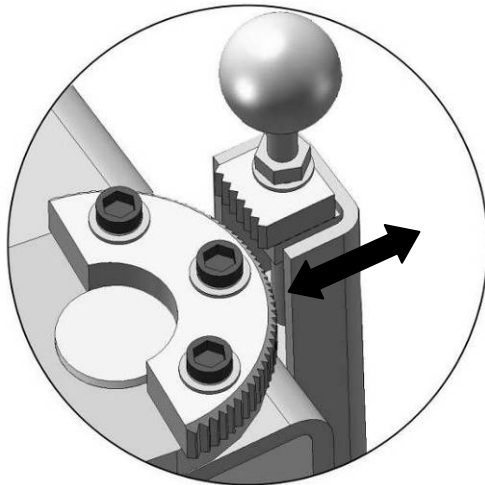

Fig. 34

4. Adjust the Teeth of Arm Locks assembly. Make it mesh with the Gear on the Lifting arm. Tighten the Hex Bolts on the Arm Lock assembly (See Fig. 35).

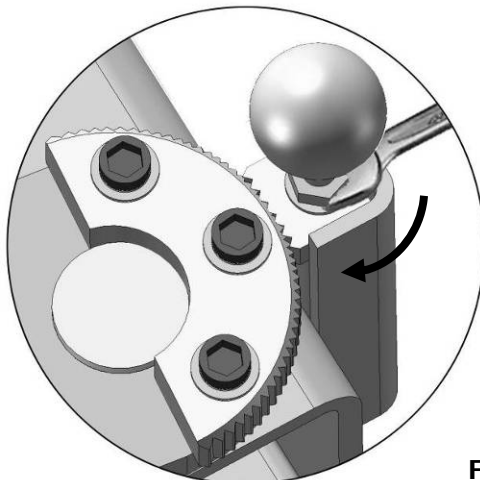

Fig. 35

## O. Install Electrical System

Connect the power source as illustrated on the power unit data plate.

**Note: 1. For operational safety, the electrical wiring must have adequate ground.**

### ATLAS single phase motor for Model 209/209X (See Fig. 36)

1. Connect the two power supply lines (fire wire **L** and zero wire **N**) to terminals on the AC contactor marked **L1, L2**.
2. Connect the two motor wires to terminals on the AC contactor marked **T1, T2**.
3. Connect **A2** to **L2** of AC contactor.
4. Two wires on the control button connect with terminals on the AC contactor marked **A1, L1**.

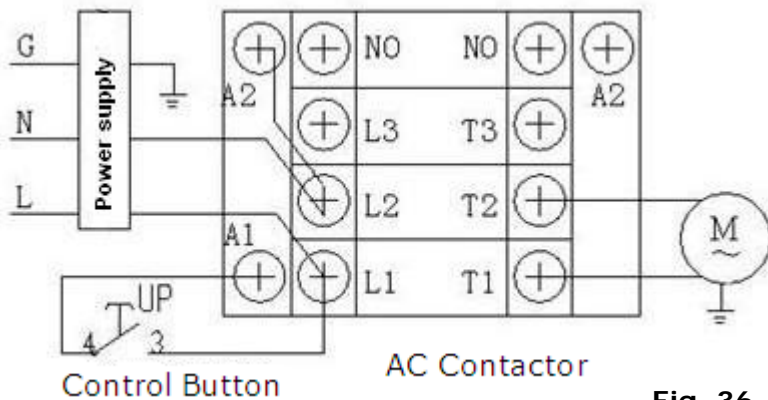
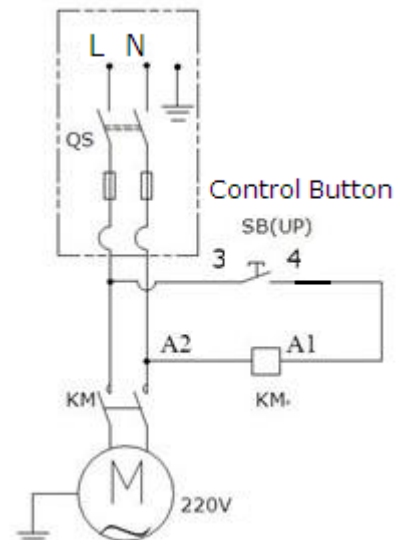

Fig. 36



### SPX single phase motor for Model 209/209X (See Fig. 37).

1. Power supply line (fire wire **L**) connected with wire ④ of control button.
2. wire ③ of control button connected with wire ⑥ of motor.
3. Power supply line (zero wire **N**) connected with wire ⑤ of motor.

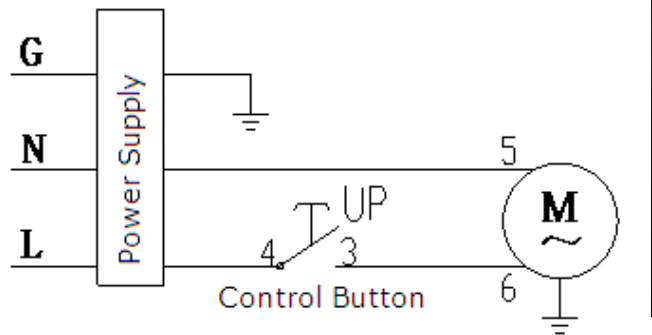
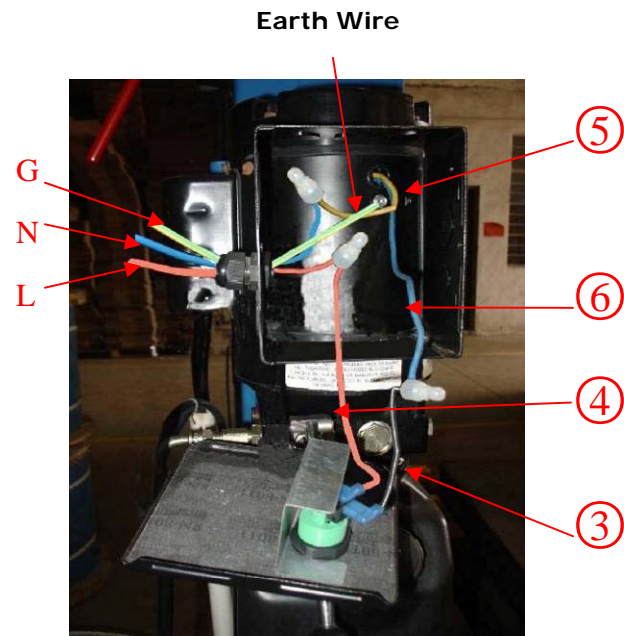
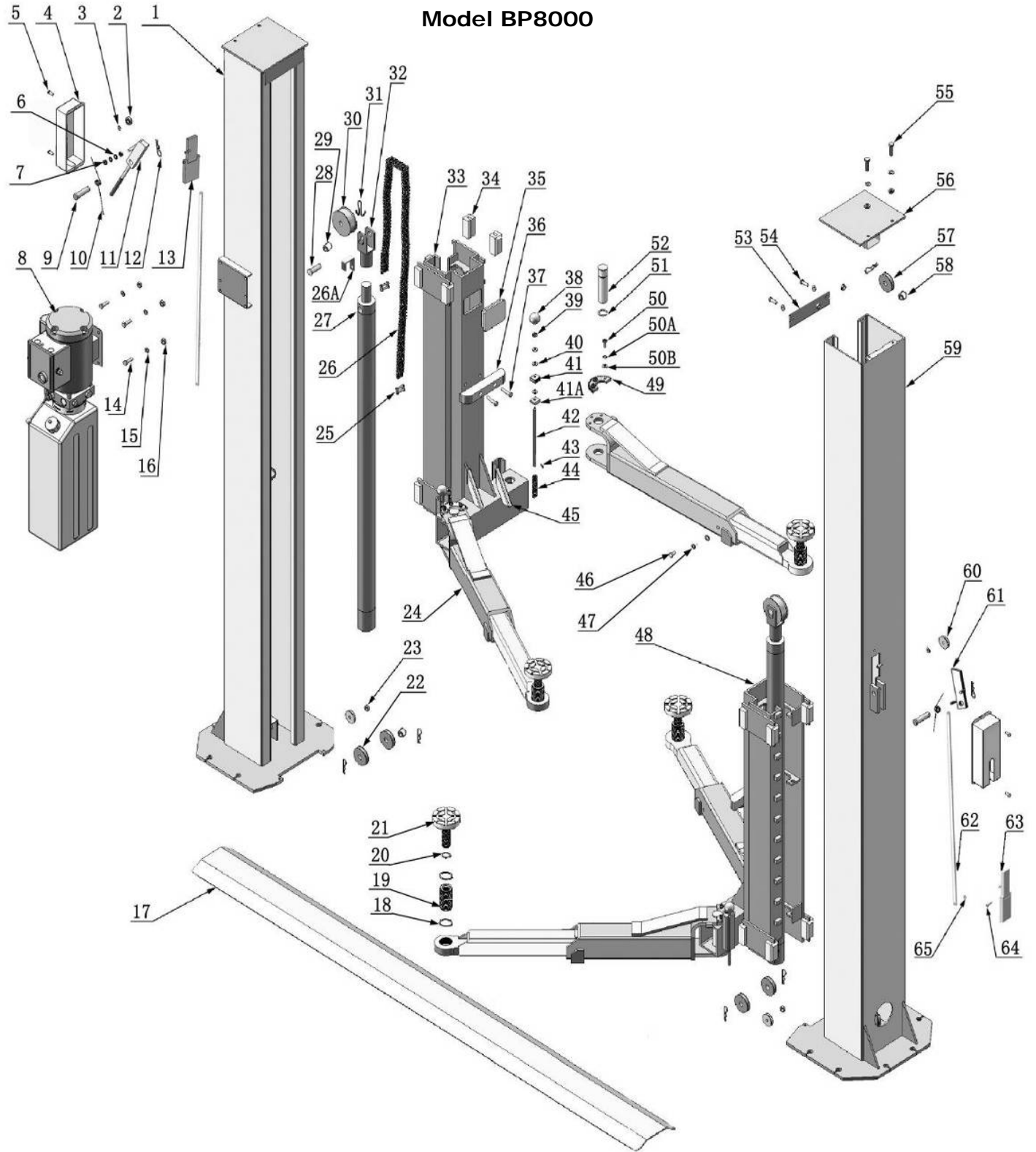

Fig. 37



# IV. EXPLODED VIEW



**Fig. 40**

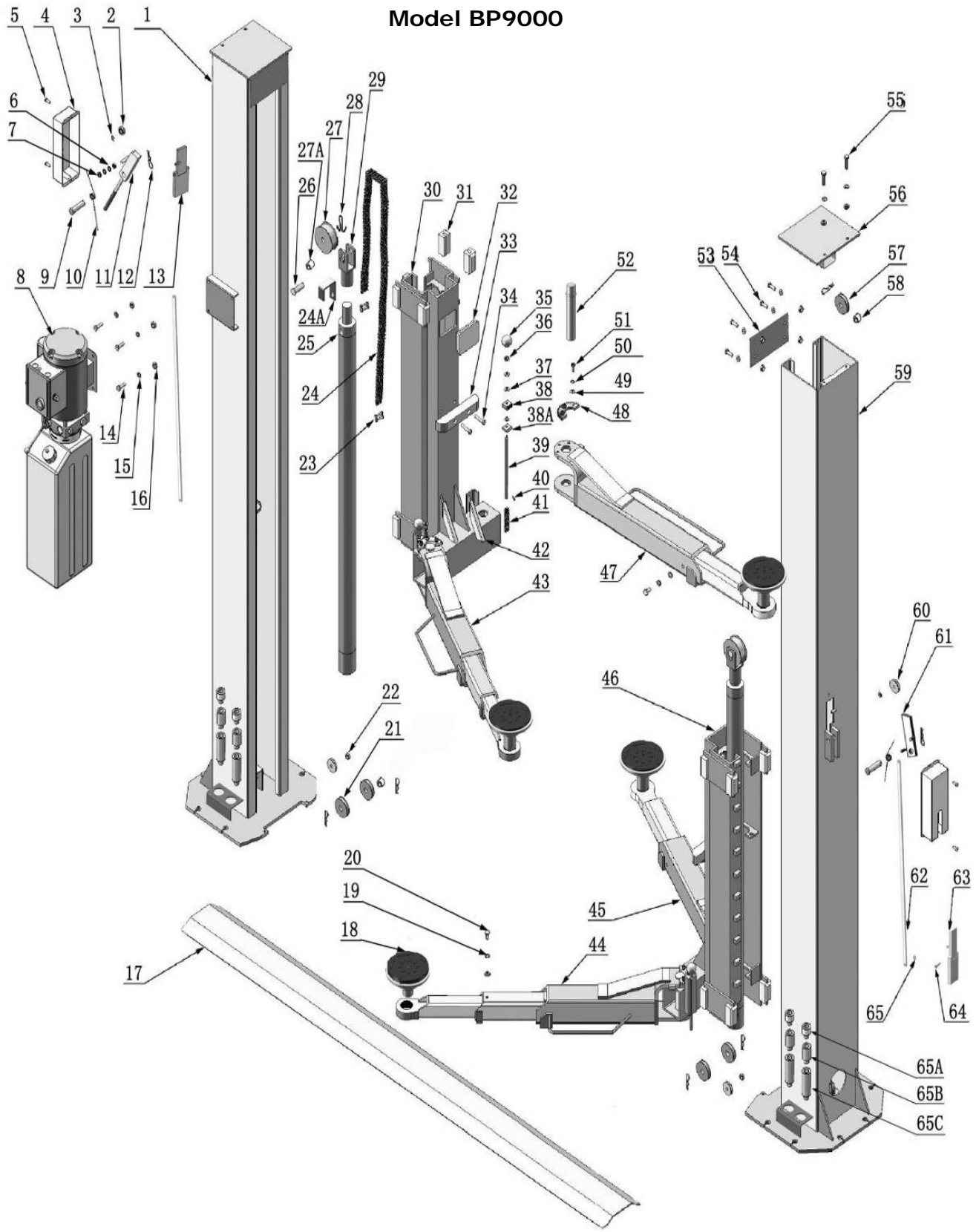

Fig. 41

## Cylinders

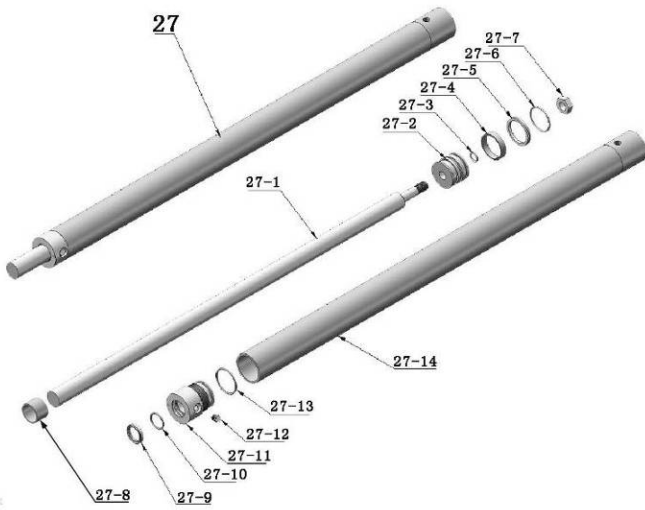

Fig. 42 Model 209

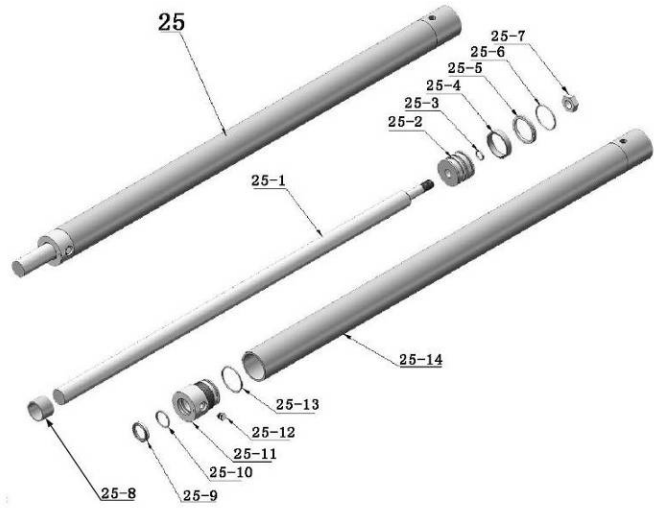
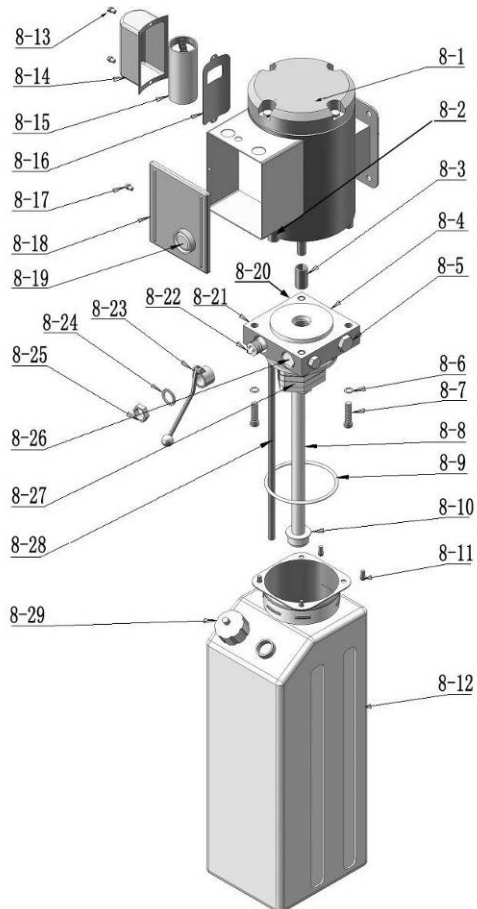

Fig. 43 Model 209X

## Hydraulic Power Unit

SPX hydraulic power unit for  
Model 209/209X



ATLAS hydraulic power unit for  
Model 209/209X

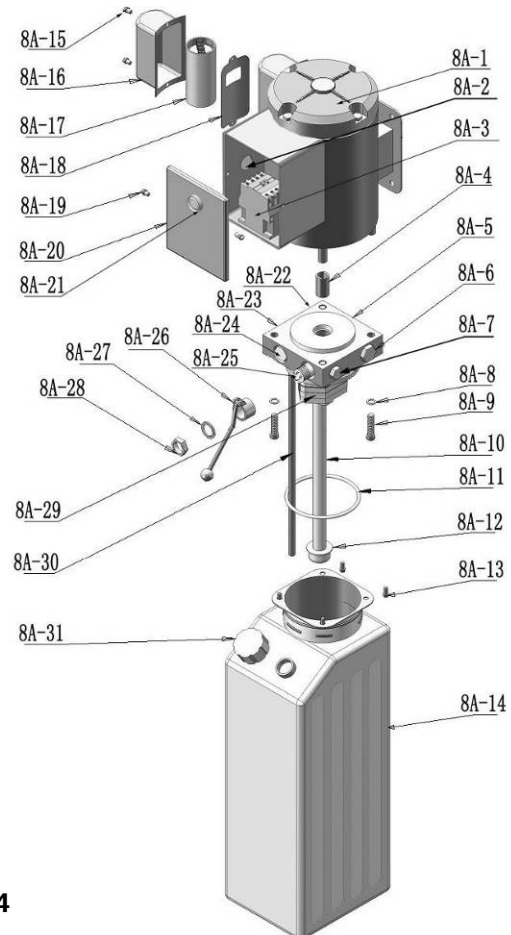

Fig. 44

# Illustration of Hydraulic Valve for SPX & ATLAS hydraulic power unit

## A. SPX hydraulic power unit (See Fig. 45)



Fig. 45

## B. ATLAS hydraulic power unit (See Fig. 46)

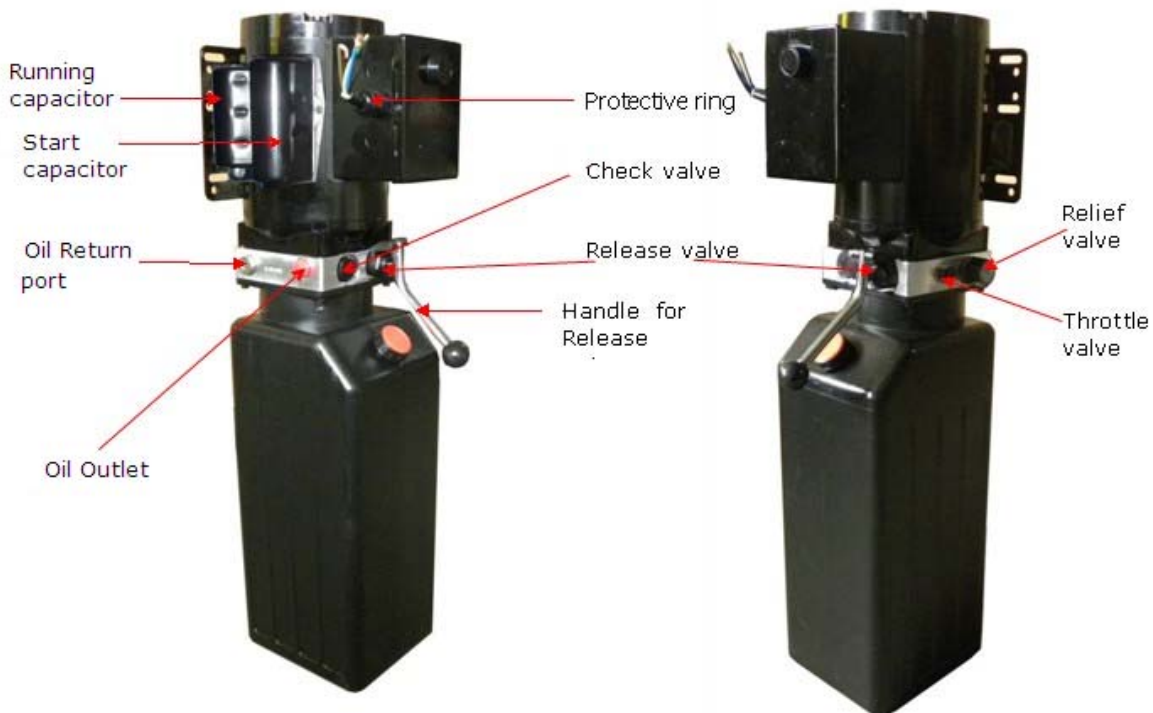

Fig. 46

## V. TEST RUN

### 1. Adjust Synchronizing Cables (See Fig. 47)

Carriages must be on first set of locks.

Use vise grips to hold the cable fitting, meanwhile

Use a wrench to tighten the cable nut.

Make sure the two cables have the same tension so the carriages lift at the same time.

Install the plastic covers on the carriages.

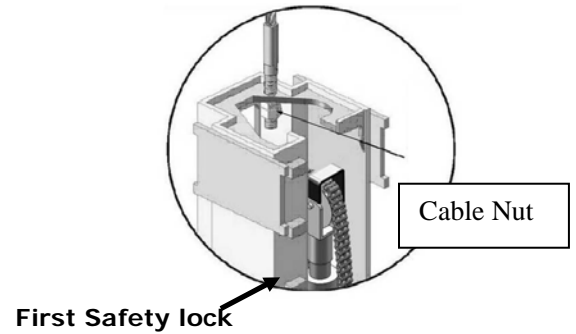

Fig. 47

### If the carriages do not synchronize when lifting, please read below: (See Fig. 48 & Fig. 49)

a. Press **UP** button to lift the carriages up to the position where the first safety lock of one carriage is higher than the safety lock on the column. Lower the lift until the lower of the two carriages makes contact with the safety lock on the column.

b. Loosen the safety lock cable. Release the safety lock on the side where the carriage is in the higher position. The other side of the safety lock should be engaged at this time. Then lower the lift, and the side with the carriage in the lower position will remain locked in the same place, and the other side (higher side) is unlocked. Continue to lower down the lift until the higher carriage is at the same level as the lower carriage.

c. Loosen the jam nut on the higher carriage synchronizing cable and tighten the tension nut until the synchronizing cable has the same tension as the other synchronizing cable. Tighten the jam nut and safety cable.

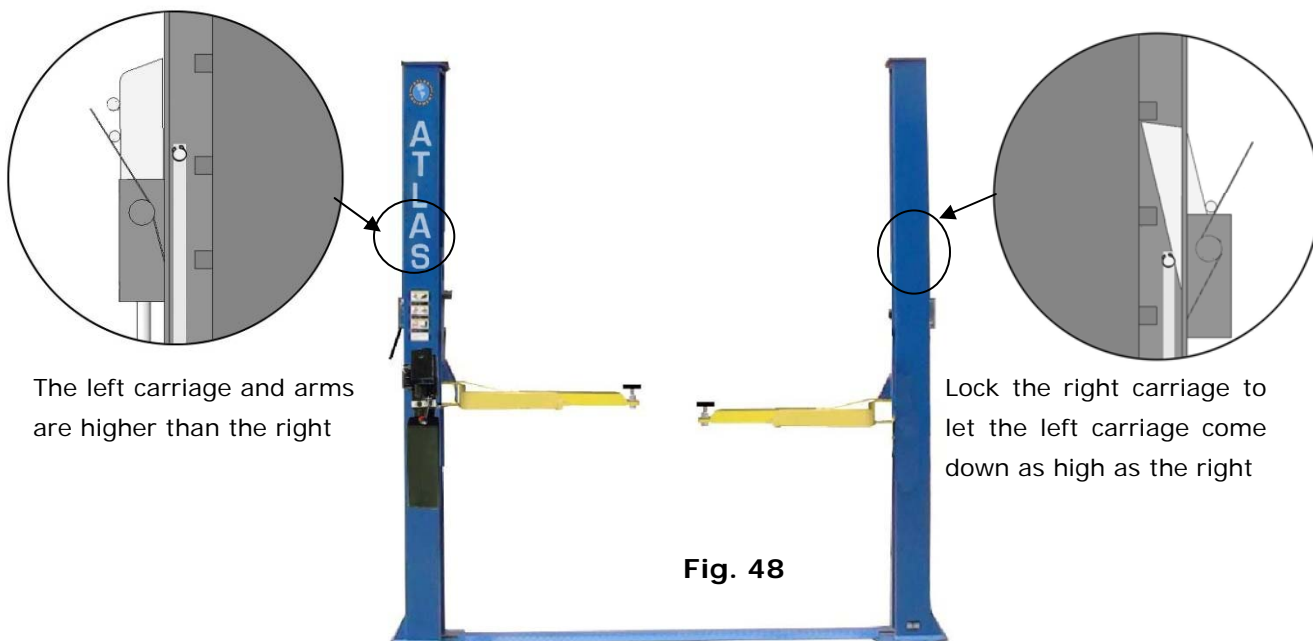



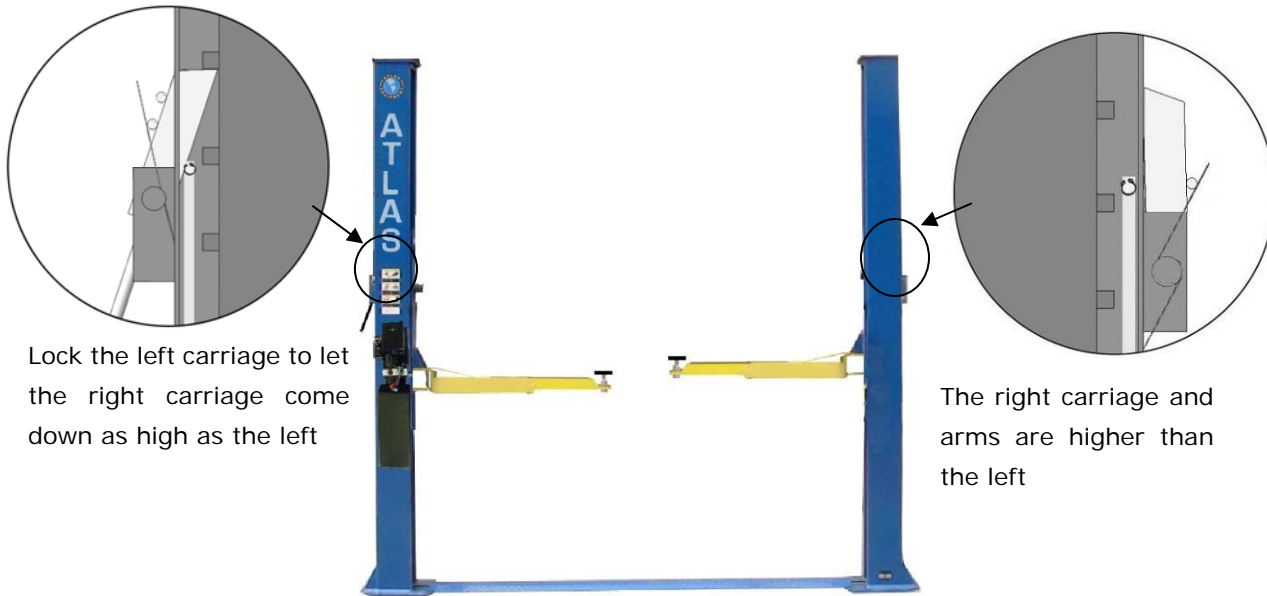

Fig. 49

## 2. Adjust Safety Cable

Lift the carriage and lock at the same height, strain the Safety Cable and then release a little, and then tighten the cable locking nuts. Make sure the safety device functions properly.

## 3. Adjust the lower speed (Only for ATLAS power unit)

You can adjust the lowering speed of the lift if needed. Loosen the locking nut on the Throttle Valve and turn the Throttle Valve clockwise to decrease the lowering speed or counterclockwise to increase the lowering speed. Do not forget to tighten the locking nut after the lowering speed adjustment has been done. **Note: This procedure must be done with a load on the lift.**

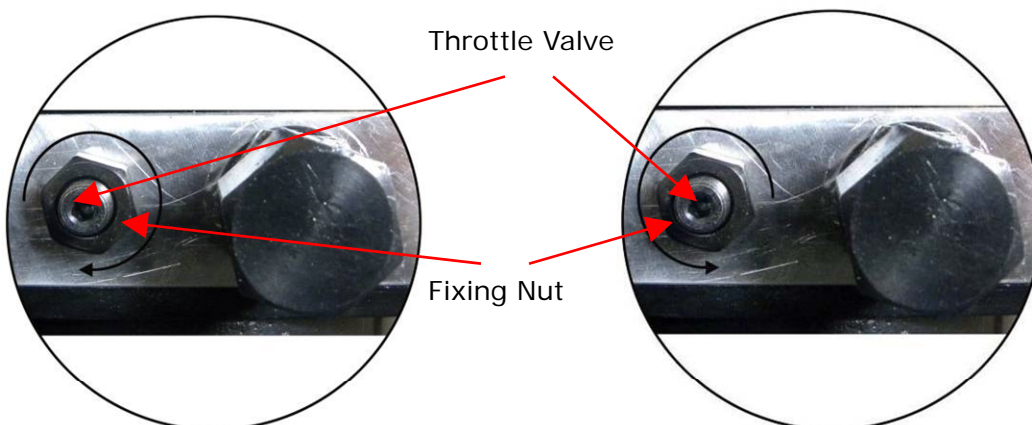

Clockwise to decrease the down speed

Counterclockwise to increase the down speed

#### 4. Test with load

After finishing the above adjustments test run the lift with load. Run the lift in the low position several times. Make sure the lift can raise and lower at the same time. Make sure the safety device can lock and release at the same time. Run the lift to the top completely.

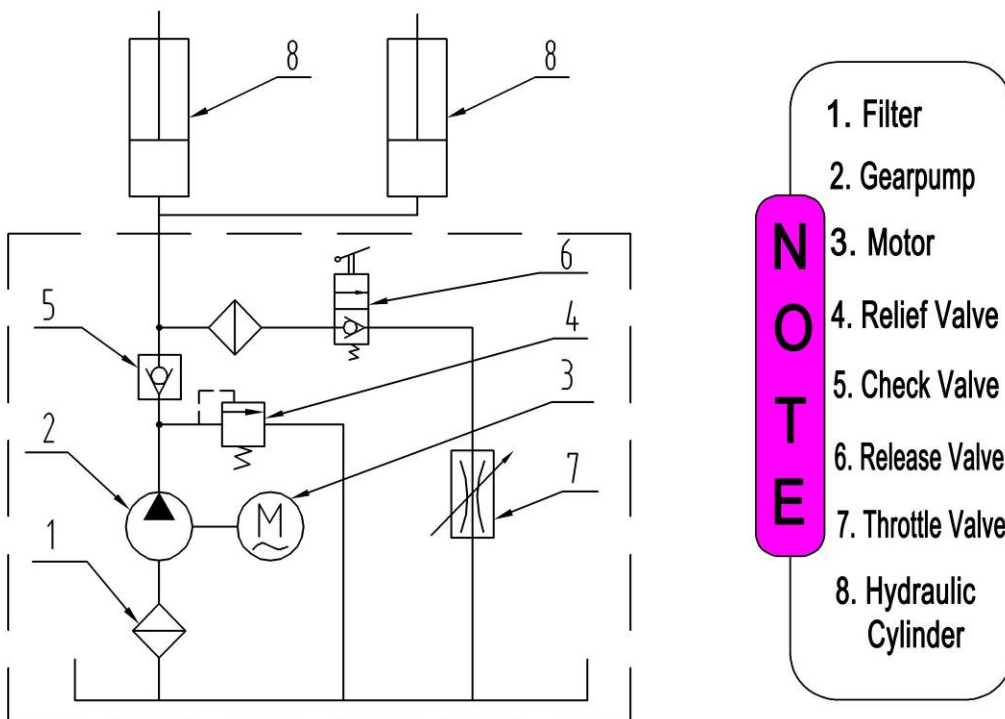

Fig. 51 Hydraulic System

## VI. OPERATION INSTRUCTIONS

**Please read the safety tips carefully before operating the lift**

### **To lift vehicle**

1. Keep the lift area free of clutter;
2. Position lift arms to the lowest position;
3. Push lift arms all the way in;
4. Open lift arms;
5. Position vehicle between columns;
6. Move arms to the vehicle's lifting point;

**Note: The four lift arms must make contact on the lifting points of the vehicle.**

Press the **UP** button until the lift pads contact underside of vehicle totally. Recheck to make sure vehicle is secure, centered and not off balance;

7. Continue to raise the lift slowly to the desired working height, ensuring the balance of vehicle;
8. Push lowering handle to lower lift onto the nearest safety lock. The vehicle is ready to repair;

### **To lower vehicle**

1. Keep the lift area free of clutter;
2. Press the button of **UP** to raise the vehicle slightly. Then release the safety lock device, lower vehicle by pushing lowering handle while holding down the safety lock handle;
3. Open the arms and position them to the shortest length;
4. Drive the vehicle away;
5. Turn off the power;

## VII.MAINTENANCE SCHEDULE

### **Monthly:**

1. Re-torque the anchor bolts to 80-117 foot lbs.;
2. Check all connectors, bolts and pins to insure proper mounting;
3. Lubricate cable with lubricant;
4. Make a visual inspection of all hydraulic hoses/lines for possible wear or leakage;
5. Check Safety device and make sure it is properly working;
6. Lubricate all Rollers and Pins with 90wt. Gear oil or equivalent;

**Note: All anchor bolts should take full torque. If any of the bolts do not function for any reason, DO NOT use the lift until the bolt has been replaced.**

**Every six months:**

1. Make a visual inspection of all moving parts for possible wear, interference or damage.
2. Check and adjust as necessary the equalizing tension of the cables to insure level lifting.
3. Check columns for plumb.
4. Check Rubber Pads and replace as necessary.
5. Check the safety locks for proper operation.

**□. TROUBLE SHOOTING**

TROUBLE	CAUSE	REMEDY
Motor does not run	<ol style="list-style-type: none"> <li>1. Button does not work</li> <li>2. Wiring connections are not in good condition</li> <li>3. Motor burned out</li> <li>4. Height Limit Switch is damaged</li> <li>5. AC contactor burned out</li> </ol>	<ol style="list-style-type: none"> <li>1. Replace button</li> <li>2. Repair all wiring connections</li> <li>3. Repair or replace motor</li> <li>4. Replace the Limit Switch</li> <li>5. Replace AC Contactor</li> </ol>
Motor runs but the lift is not raised	<ol style="list-style-type: none"> <li>1. Motor runs in reverse rotation</li> <li>2. Gear Pump out of operation</li> <li>3. Release Valve in damage</li> <li>4. Relief Valve or Check Valve in damage</li> <li>5. Low oil level</li> </ol>	<ol style="list-style-type: none"> <li>1. Reverse two power wire</li> <li>2. Repair or replace</li> <li>3. Repair or replace</li> <li>4. Repair or replace</li> <li>5. Fill tank</li> </ol>
Lift does not stay up	<ol style="list-style-type: none"> <li>1. Release Valve out of work</li> <li>2. Relief Valve or Check Valve leakage</li> <li>3. Cylinder or Fittings leaks</li> </ol>	Repair or replace
Lift raises slowly	<ol style="list-style-type: none"> <li>1. Oil line is jammed</li> <li>2. Motor running on low voltage</li> <li>3. Oil mixed with air</li> <li>4. Gear Pump leaks</li> <li>5. Overload lifting</li> </ol>	<ol style="list-style-type: none"> <li>1. Clean the oil line</li> <li>2. Check Electrical System</li> <li>3. Fill tank</li> <li>4. Replace Pump</li> <li>5. Check load</li> </ol>
Lift can not lower	<ol style="list-style-type: none"> <li>1. Safety device are in activated</li> <li>2. Release Valve in damage</li> <li>3. Safety cable broken</li> <li>4. Oil system is jammed</li> </ol>	<ol style="list-style-type: none"> <li>1. Release the safeties</li> <li>2. Repair or replace</li> <li>3. Replace</li> <li>4. Clean the oil system</li> </ol>

**For more detail on motor troubleshooting visit our web site at [gregsmithequipment.com](http://gregsmithequipment.com). Go to "Knowledge Base" and click on "Troubleshooting and Repair".**

## IX. Parts List For Model BP8000 and BP9000

### A. Parts For Model BP8000 (See Fig. 40, Fig. 6)

Item.	Part No.	Description	Qty.	Note
1	205001	Power side Post	1	
2	209011	Plastic Pulley	1	
3	209010	Snap Ring	2	
4	209008	Safety Cover	2	
5	209009	Cup Head Bolt	4	
6	206006	Washer	2	
7	206023A	Hex Nut	2	
8	209002	Hydraulic Power Unit	1	
9	209006	Safety Pin	2	
10	209007	Safety Spring	2	
11	203002	Power side Safety Assembly	1	
12	209012	Hair Pin	8	
13	203015	Safety Block (Main Side)	1	
14	209003	Hex Bolt	4	
15	209004	Rubber Ring	4	
16	209005	Nylok Nut	8	
17	205002	Floor Cover	1	
18	206033	Snap Ring	8	
19	206034	Outer Screw	4	
20	206032	Snap Ring	4	
21	206031	Inner Screw Assy.	4	
22	209057	Small Pulley	4	
23	209056	Nylok Nut	2	
24	201039	Lifting Arm (screw-in)	4	
25	201010	Chain Connector	4	
26	201009A	Chain	2	
26A	201042	Chain Protective Cover	2	
27	201008A	Hydraulic Cylinder	2	
28	201007	Pin For Chain Pulley	2	
29	203004A	Bronze Bush For Chain Pulley	4	
30	201006	Chain Pulley	2	
31	201005	Split Pin	2	
32	201004	Chain Pulley Assy.	2	
33	205003	Power side Lifting Head	1	
34	206044	Slider	16	
35	209016	Carriage Plastic Cover	2	
36	206045	Protective Rubber	2	
37	206046	Self-tapping Screw	4	
38	209020	Plastic Ball	4	
39	209021	Hex Nut	12	
40	209022	Washer	12	
41	209023A	Teeth	4	
42	209024	Arm Lock Bar	4	

Item.	Part No.	Description	Qty.	Note
43	209025	Hair Pin	4	
44	209026	Spring	4	
45	209027	Protective Rubber Set	4	
46	209038	Hex Bolt	4	
47	209039	Spring Washer	12	
48	205004	Offside Lifting Head	1	
49	209035	Gear	4	
50	209032	Socket Bolt	12	
50A	209034	Spring Washer	12	
50B	209033	Washer	20	
51	209031	Snap Ring	4	
52	209030A	Lifting Arm Pin	4	
53	205005	Connecting Bar	2	
54	209043	Hex Bolt	4	
55	209046	Hex Bolt	4	
56	205006	Top plate	2	
57	209045	Big Pulley	2	
58	209057A	Bronze bush for Pulley	6	
59	205007	Offside Post	1	
60	209049	Plastic Pulley	3	
61	203012	Offside Safety Assy.	1	
62	203013	Coupling	2	
63	203014	Safety Block (Second Side)	1	
64	203018	Socket Bolt	4	
65	203016	Snap Ring	2	
66	209059	Anchor bolt	12	
<b>Oil Hose, Fitting &amp; Cable (See Fig. 26, Fig. 27 Fig. 28 &amp; Fig. 29)</b>				
67	209060	90° Fitting for Hydraulic Power Unit	1	
68	201021	Oil Hose	1	
69	201022	T-Fitting	1	
70	205008	Oil Hose	1	
71	201020	90° Fitting	1	
72	205009	Cable	2	
73	209066	Cable Nut	4	
74	205010	Safety Cable	1	
<b>Optional Arms with Stackable Adaptors (See Fig. 40)</b>				
Item.	Part No.	Description	Qty.	Note
75	201040	Lifting Arms (drop-in)	4	
76	680030	Rubber Pad Frame Support	4	
77	209053	Stackable Adapter (6")	4	
78	209051	Stackable Adapter (1.5")	4	
79	209052	Stackable Adapter (3")	4	

Item.	Part No.	Description	Qty.	Note
<b>Parts For Hydraulic Cylinder (See Fig. 42)</b>				
27-1	201027A	Piston Rod	2	
27-2	201028	Piston	2	
27-3	206069	O-Ring	3	
27-4	201029	Support Ring	2	
27-5	201030	Y-Ring	2	
27-6	201031	O-Ring	2	
27-7	206071	Hex Nut	2	
27-8	201037	Adjustment Tube	2	
27-9	209078	Dust Seal	2	
27-10	201032	O-Ring	2	
27-11	201033	Head Cap	2	
27-12	201034	Bleeding Plug	2	
27-13	201035	O-Ring	2	
27-14	201036A	Bore Weldment	2	

**B. Parts For Model BP9000 (See Fig. 41, Fig. 6)**

Item.	Part No.	Description	Qty.	Note
1	203001	Power side Post	1	
2	209011	Plastic Pulley	1	
3	209010	Snap Ring	2	
4	209008	Safety Cover	2	
5	209009	Cup Head Bolt	4	
6	206006	Washer	2	
7	206023A	Hex Nut	2	
8	209002	Hydraulic Power Unit	1	
9	209006	Safety Pin	2	
10	209007	Safety Spring	2	
11	203002	Power side Safety Assy.	1	
12	209012	Hair Pin	8	
13	203015	Safety Block (Main Side)	1	
14	209003	Hex Bolt	4	
15	209004	Rubber Ring	4	
16	209005	Nylok Nut	8	
17	203003	Floor Cover	1	
18	680030	Rubber Pad Frame Support	4	
19	209039	Spring Washer	14	
20	209038	Hex Bolt	6	
21	209057	Small Pulley	4	
22	209056	Nylok Nut	2	
23	201010	Chain Connector	4	
24	203005	Chain	2	
24A	201042	Chain Protective Cover	2	

Item.	Part No.	Description	Qty.	Note
25	201008	Hydraulic Cylinder	2	
26	201007	Pin For Chain Pulley	2	
27	203004	Chain Pulley	2	
27A	203004A	Bronze bush for Chain Pulley	4	
28	201005	Split Pin	2	
29	201004	Chain Pulley Assy.	2	
30	203007	Power side Lifting Head	1	
31	206044	Slider	16	
32	209016	Carriage Plastic Cover	2	
33	206045	Protective Rubber	2	
34	206046	Self-tapping Screw	4	
35	209020	Plastic Ball	4	
36	209021	Hex Nut	12	
37	209022	Washer	12	
38	209023A	Teeth	4	
39	209024	Arm Lock Bar	4	
40	209025	Hair Pin	4	
41	209026	Spring	4	
42	209027	Protective Rubber Set	4	
43	201012C	Lifting Arm - Front Right (Drop-in)	1	
44	201013C	Lifting Arm - Front Left (Drop-in)	1	
45	201014B	Lifting Arm - Rear Left (Drop-in)	1	
46	203008	Offside Lifting Head	1	
47	201016B	Lifting Arm - Rear Right (Drop-in)	1	
48	209035	Gear	4	
49	209033	Washer	20	
50	209034	Spring Washer	12	
51	209032	Socket Bolt	12	
52	209030	Lifting Arm Pin	4	
53	203009	Connecting Bar	2	
54	209043	Hex Bolt	8	
55	209046	Hex Bolt	4	
56	203010	Top plate	2	
57	209045	Big Pulley	2	
58	209057A	Bronze Bush For Pulley	6	
59	203011	Offside Post	1	
60	209049	Plastic Pulley	3	
61	203012	Offside Safety Assy.	1	
62	203013	Coupling	2	
63	203014	Safety Block (Second Side)	1	
64	203018	Socket Bolt	4	
65	203016	Snap Ring	4	
65A	209051	Stackable Adapter (1.5")	4	



65B	209052	Stackable Adapter (3")	4	
<b>Item.</b>	<b>Part No.</b>	<b>Description</b>	<b>Qty.</b>	<b>Note</b>
65C	209053	Stackable Adapter (6")	4	
66	209059	Anchor bolt	12	
<b>Oil Hose, Fitting &amp; Cable (See Fig. 26, Fig. 27 Fig. 28 &amp; Fig. 29)</b>				
67	209060	90° Fitting for Hydraulic Power Unit	1	
68	201021	Oil Hose	1	
69	201022	T-Fitting	1	
70	203019	Oil Hose	1	
71	201020	90° Fitting	1	
72	203020	Cable	2	
73	209066	Cable Nut	4	
74	203021	Safety Cable	1	
<b>Optional Amy Kits With Screwed Rubber Pads (See Fig. 41)</b>				
75	201016	Lifting Arm - Rear Right (Screw-in)	1	
75A	201014	Lifting Arm - Rear Left (Screw-in)	1	
76	201012	Lifting Arm - Front Right (Screw-in)	1	
76A	201013	Lifting Arm - Front Left (Screw-in)	1	
77	206031	Inner Screw Assy.	4	
78	206032	Snap Ring	4	
79	206034	Outer Screw	4	
80	206033	Snap Ring	8	
<b>Parts For Hydraulic Cylinder (See Fig. 43)</b>				
25-1	201027	Piston Rod	2	
25-2	201028	Piston	2	
25-3	206069	O-Ring	2	
25-4	201029	Support Ring	2	
25-5	201030	Y-Ring	2	
25-6	201031	O-Ring	2	
25-7	206071	Hex Nut	2	
25-8	201037	Adjustment Tube	2	
25-9	209078	Dust Seal	2	
25-10	201032	O-Ring	2	
25-11	201033	Head Cap	2	
25-12	201034	Bleeding Plug	2	
25-13	201035	O-Ring	2	
25-14	201036	Bore Weldment	2	

**Parts List Of Power Unit For Model 209 & 209X (See Fig. 44)**

<b>Parts For SPX Power Unit</b>				
<b>Item.</b>	<b>Part No.</b>	<b>Description</b>	<b>Qty.</b>	<b>Note</b>
8-1	209082	Motor	1	
8-2	209109	Protective Ring	1	
8-3	209083	Motor Connecting Shaft	1	
8-4	209084	Valve Body	1	
8-5	209085	Relief Valve	1	
8-6	209086	Spring Washer	4	
8-7	209087	Socket Bolt	4	
8-8	209088	Inlet Pipe	1	
8-9	209089	O-Ring	1	
8-10	209090	Filter	1	
8-11	209091	Hex bolt	4	
8-12	209092	Reservoir	1	
8-13	209093	Bolt	2	
8-14	209094	Cover of Capacitor	1	
8-15	209095	Capacitor	1	
8-16	209096	Rubber Gasket	1	
8-17	209097	Hex bolt	1	
8-18	209098	Cover of Motor Terminal Box	1	
8-19	209099	Push Button	1	
8-20	209110	Oil Return Port	1	
8-21	209100	Oil Outlet	1	
8-22	209101	Release Valve	1	
8-23	209102	Handle For Release Valve	1	
8-24	209103	Washer	1	
8-25	209104	Hex Nut	1	
8-26	209105	Check Valve	1	
8-27	209106	Gear Pump	1	
8-28	209107	Oil Return Pipe	1	
8-29	209108	Filler Cap	1	

**Parts For PEAK Power Unit**

<b>Item.</b>	<b>Part No.</b>	<b>Description</b>	<b>Qty.</b>	<b>Note</b>
8A-1	209082A	Motor	1	
8A-2	209109	Protective Ring	1	
8A-3	209112	AC contactor	1	
8A-4	209083A	Motor Connecting Shaft	1	
8A-5	209084A	Valve Body	1	
8A-6	209085A	Relief Valve	1	
8A-7	209113	Throttle valve	1	
8A-8	209086A	Spring Washer	4	
8A-9	209087A	Socket Bolt	4	
8A-10	209088A	Inlet Pipe	1	
8A-11	209089A	O-Ring	1	
8A-12	209090A	Filter	1	
8A-13	209091A	Socket bolt	4	
8A-14	209092A	Reservoir	1	
8A-15	209093A	Cup Head Bolt	4	
8A-16	209094A	Cover of Capacitor	2	
8A-17	209095A	Capacitor	2	
8A-18	209096A	Rubber Gasket	2	
8A-19	209097A	Cup Head Bolt	2	
8A-20	209098A	Cover of Motor Terminal Box	1	
8A-21	209099A	Push Button	1	
8A-22	209110A	Oil Return Port	1	
8A-23	209100A	Oil Outlet	1	
8A-24	209105A	Check Valve	1	
8A-25	209101A	Release Valve	1	
8A-26	209102A	Handle For Release Valve	1	
8A-27	209103A	Washer	1	
8A-28	209104A	Hex Nut	1	
8A-29	209106A	Gear Pump	1	
8A-30	209107A	Oil Return Pipe	1	
8A-31	209108A	Filler Cap	1	