



ATLAS OH-10X

10,000 lb. Capacity
Two-Post Overhead Lift

QUICK START GUIDE



INDIANA

GREG SMITH EQUIPMENT SALES INC.
5800 MASSACHUSETTS AVE.
INDIANAPOLIS, IN 46218

PHONE: (800) 262-1950
FAX: (317) 542-1448

DELAWARE

GREG SMITH EQUIPMENT, INC.
250 EXECUTIVE DRIVE, SUITE 1
NEWARK, DE 19702

PHONE: (800) 715-1950
FAX: (302) 894-9136

GEORGIA

GREG SMITH EQUIPMENT, INC.
5405 BUFORD HWY.
NORCROSS, GA 30071

PHONE: (800) 768-4104
FAX: (678) 781-0149

ARIZONA

GREG SMITH EQUIPMENT, INC.
8399 W VAN BUREN ST., SUITE 210
TOLLESON, AZ 85353

PHONE: (800) 602-9928
FAX: (602) 490-3495

TABLE OF CONTENTS

Product Features and Specifications.....	2
Installation Instructions	3
Assembly	4

TECHNICAL SPECIFICATIONS

FEATURES

- Direct-Drive cylinder minimizes the lift wear parts.
- Dual hydraulic direct-drive cylinders are made to ANSI standard
- Self-lubricating UHMW Polyethylene sliders and bronze bushings are used to reduce friction.
- Single-point lock release with a dual lock design.
- Automatic arm restraints.
- Clearfloor design provides unobstructed floor space.
- Overhead safety shut-off bar.
- Rubber pad adapters with a set of truck adapters.

Model	Atlas OH10X
Style	Clearfloor Direct-drive
Lifting Capacity	10000 lbs.
Lifting Time	55 Seconds
Lifting Height I	77.7" (88" with T/A)
Overall Height	151.6" (11'7.5')
Overall Width	144.63"
Width Between Posts	118.3"
Minimum Pad Height	4.3"
Motor	220V/1PH

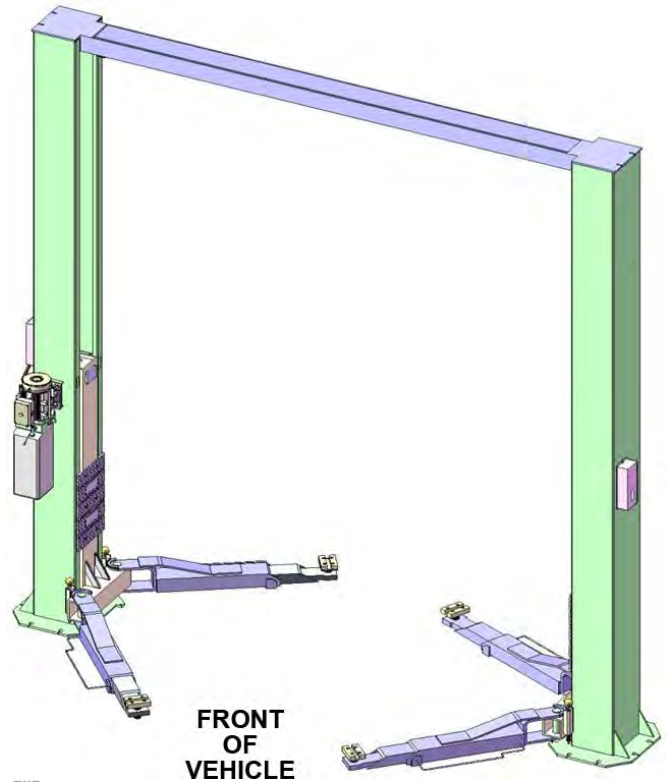

Arm Swing

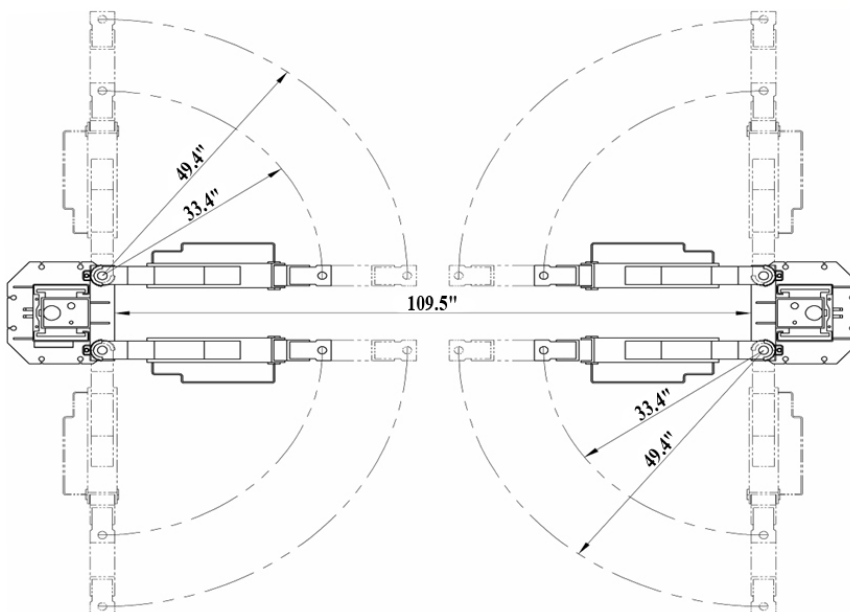

Fig. 2

INSTALLATION INSTRUCTIONS

TOOLS REQUIRED

- Rotary Hammer Drill (3/4" drill bit)
- Hammer
- Foot Level
- Ratchet spanner with socket (10#, 13#, 14#, 15#, 17#, 24#, 27#)
- Hex-key/Allen Wrench Set (5#)
- Chalk Line
- Tape Measure (25ft)
- Needle Nose Pliers
- Lock Wrench

SPECIFICATIONS OF CONCRETE

Make sure your concrete meets the requirements below before you begin the installation and assembly of the lift.

- Concrete must have a minimum thickness of 4" (3000 psi)
- Make sure that reinforcing steel bars will not deflect drill bit.
- Concrete must be in good condition and fully cured.
- Floors must be level and have no deep cracks that can cause anchor bolts to pull out.

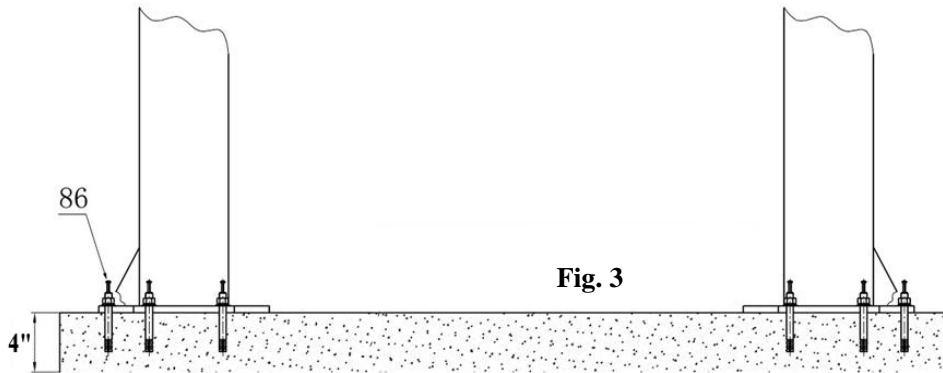

STEP 1: Check the Parts Before Assembly

- A. Unwrap the lift and check the parts according to the shipment parts list (*see picture 1*)



Picture 1

- B. Open the box of parts and check to make sure all parts are included. (*see picture 2*)

- C. Open parts **bag** and verify quantities (*see picture 3*)



Picture 2



Picture 3

ASSEMBLY

STEP 1: Find a suitable location for the installation of your lift.
You may want to center the lift in the door.

NOTE: You must have a minimum **13' ceiling** to stand the columns upright.

STEP 2: Use a chalk line to mark out an installation area, for the column bases. (See Fig. 4)

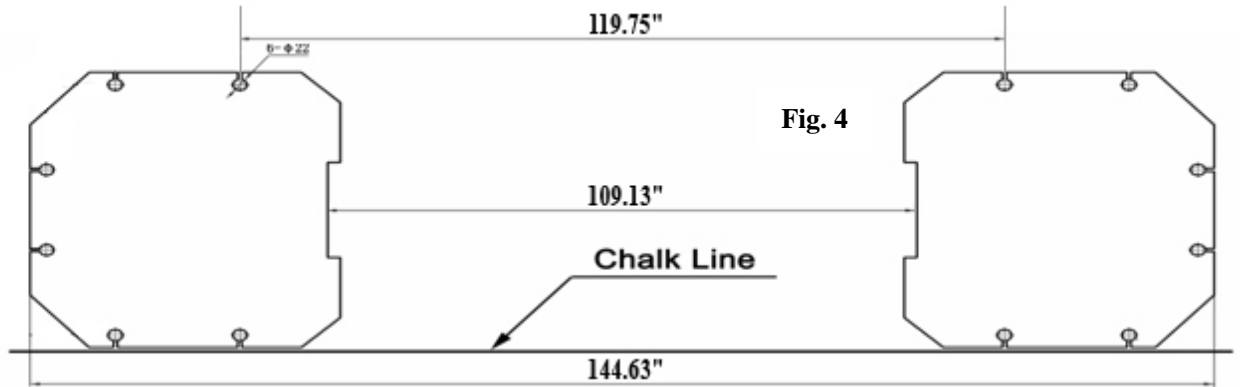

STEP 3: Stand both columns up and align the bases of the columns with the marked chalk line. It is suggested to install the power-side (column with the power unit attached) column on the front-right side (passenger side).

IMPORTANT: Make sure that the “PEG” attached to the bottom of the cylinder (one cylinder in each column) is completely inserted into the hole located on the inside base of the column. This peg locks the cylinder in place and insures that the cylinder is in the center of the column. The cylinder must be properly installed to allow the carriage to be fully lowered and the automatic arm lock pin is disengaged to allow the arms to move.

NOTE: You must have a minimum **13' ceiling** to install this lift.

STEP 4: Mount the Powerside Column to the concrete first: (Do not anchor the slave column now)

Use the rotary hammer drill to drill all the anchor holes in the Powerside Column and install the anchor bolts. Level and plumb the posts with each other by using a plastic or metal shim. Tighten the anchor bolts (65 lbs. to 85 lbs.) to mount the Power-side Column.

SPIKE TYPE ANCHOR BOLTS:

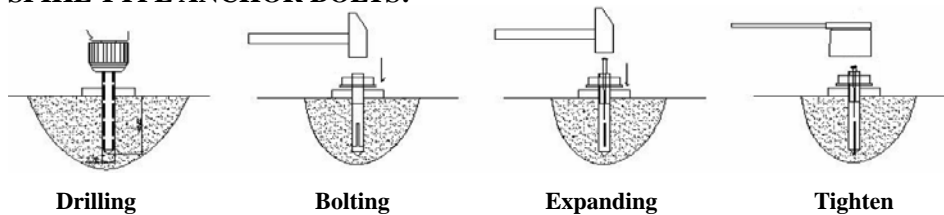

WEDGE TYPE ANCHOR BOLTS:

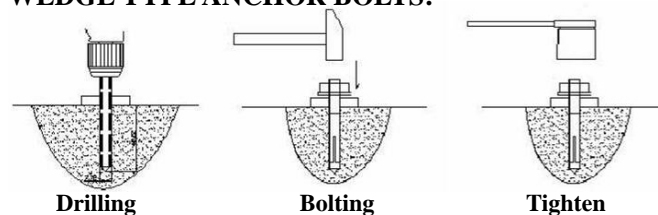

STEP 5: Install the Overhead Beam to both columns with the included hardware.

STEP 6: Install Hydraulic Hose Assembly

Note: The direction of Hydraulic Cylinder Fitting and the connection of the Oil Hose Assembly should be similar to the diagram of Hydraulic System. (See Fig. 5)

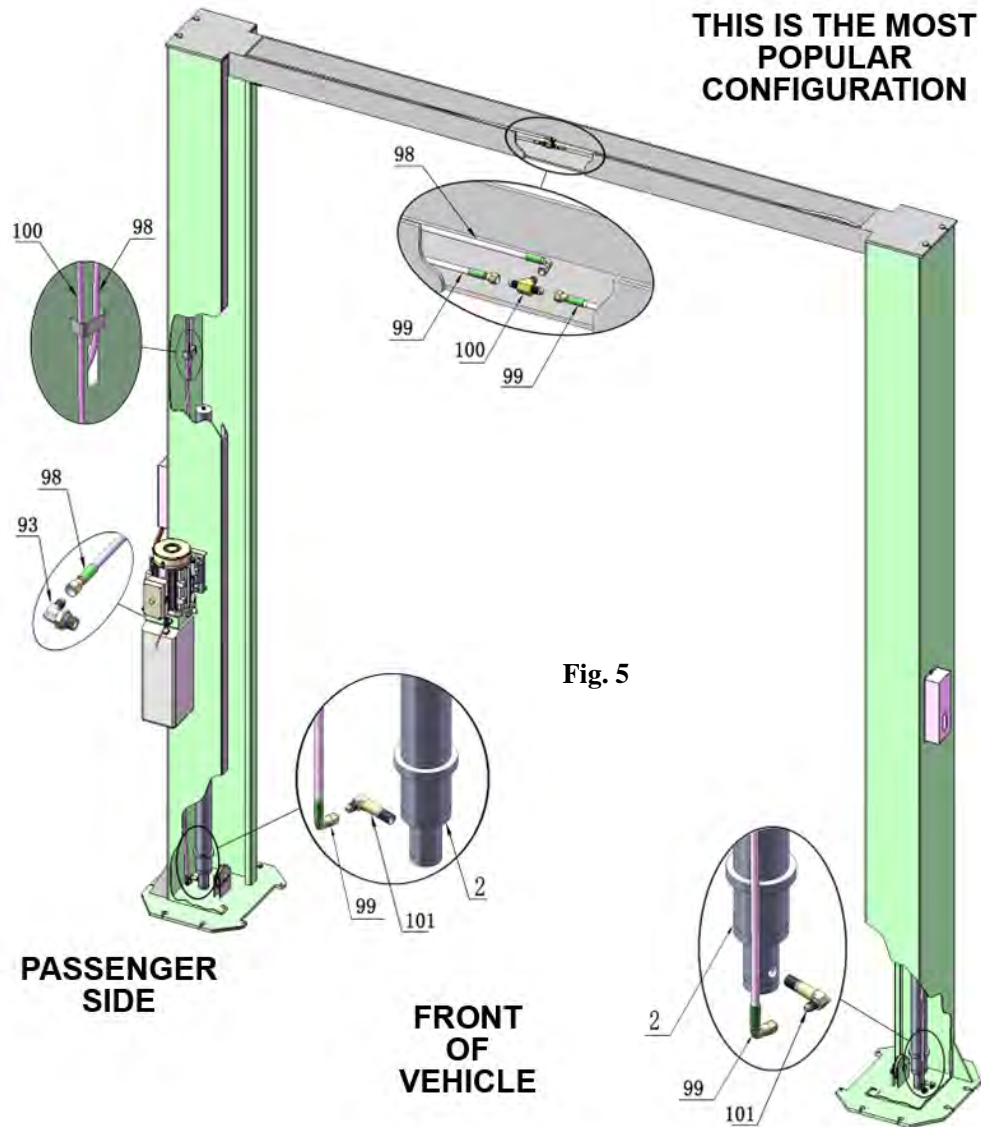

STEP 7: Now mount the Slave Column (column without the power unit) to the concrete (same mounting procedures as Power-side Column. Make sure both columns are level and plumb with each other using shims. Tighten the anchor bolts (65 lbs.-85 ft. lbs.) to securely mount the Slave Column.

STEP 8: Install Cable (*see Fig. 6*)

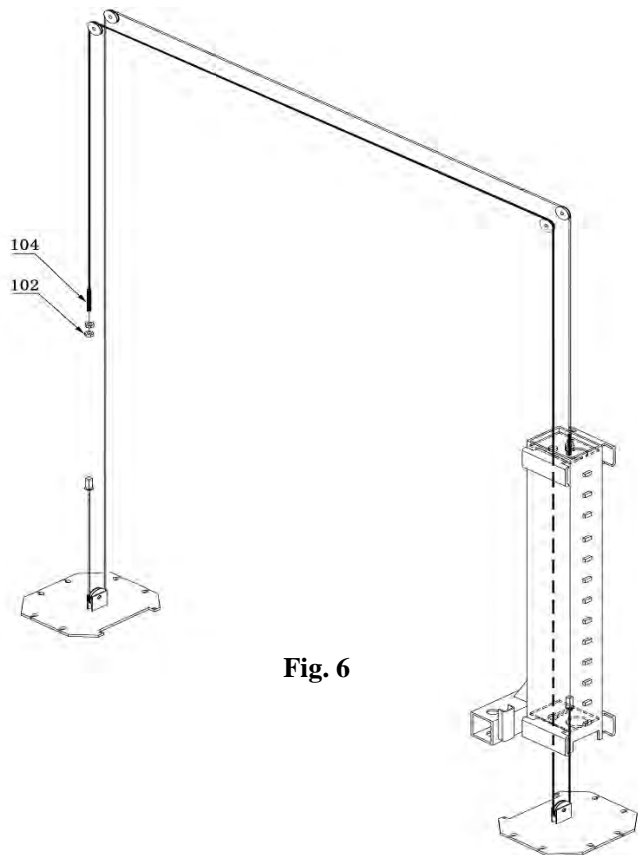

Fig. 6

STEP 9: Install Safety Locks and Safety Lock Release cable. (*see Fig. 7*)

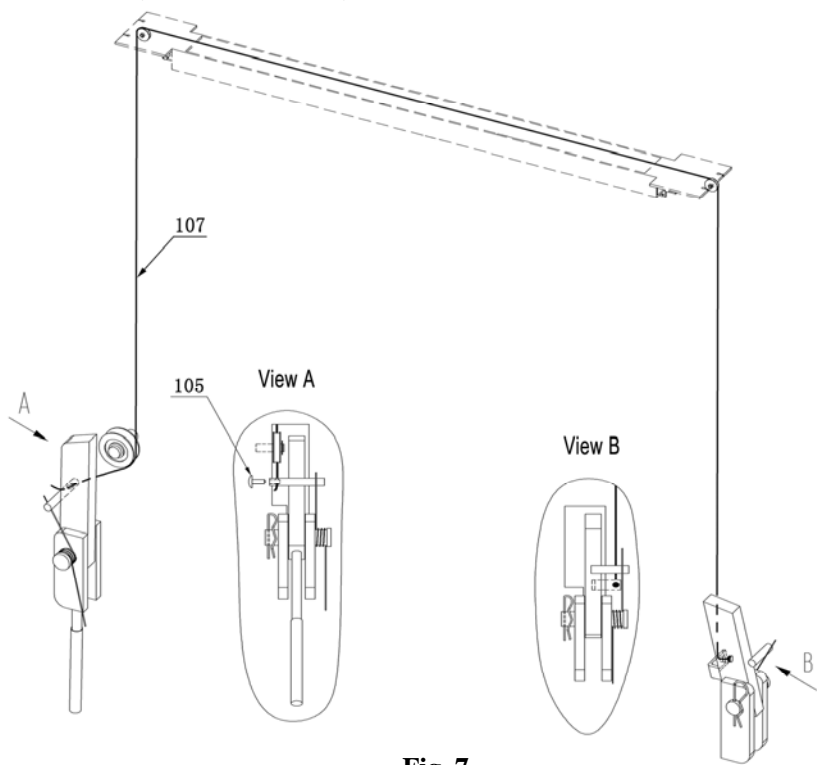
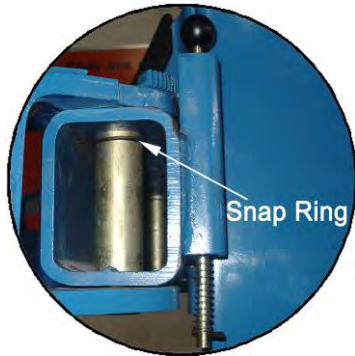

Fig. 7

STEP 10: Install Lifting Arms and Pads: Install the Lift Arms, Lift Pads and Snap Rings (*See picture 3*) Attach the Power Unit to the Powerside Column, connect hydraulic hoses and tighten all the hydraulic fittings (snugly). Fill the tank with #32 or #46 Hydraulic oil.



Picture 3

STEP 11: Install the “Overhead Shut-Off Bar” Limit Switch.

STEP 12: Identify the **#1 HOT WIRE** from the power source and connect to the Overhead Shut Off Bar Limit Switch. After the limit switch has been connected (wire nut and tape properly) into the **#1 HOT WIRE**, connect the **#1 HOT WIRE** to the **L2** connection inside the power unit electrical box.

STEP 13: Identify the **#2 HOT WIRE** and connect it directly to the **L3** connection inside of the power unit electrical box.

STEP 14: Connect the **GROUND WIRE** to the ground screw inside of the power unit electrical box.

