

INSTALLATION & OPERATION MANUAL

Atlas Platinum PVL140F-EXT 14,000 lb. Capacity Four-Post Open Front Lift



Atlas Automotive Equipment
www.atlasautoequipment.com
(866) 898-2604

Read this entire manual before operation begins.

Record below the following information which is located on the serial number data plate.

Serial No. _____

Model No. _____



Date of Installation _____

Contents

General Information.	5
Product Identification	8
Packing / Transport / Storage	9
Product Description	11
Technical Specification.	12
Safety	18
Installation	22
Operation And Use	40
Maintenance	43
Troubleshooting.	45
Part List	46
Warranty	66

PRINTING CHARACTERS AND SYMBOLS

Throughout this manual, the following symbols and printing characters are used to facilitate reading:

	Indicates the operations which need proper care
	Indicates prohibition
	Indicates a possibility of danger for the operators
BOLD TYPE	Important information

	WARNING: before operating the lift and carrying out any adjustment, read carefully chapter 7 “installation” where all proper operations for a better functioning of the lift are shown.
---	--

General Information

This chapter contains warning instructions to operate the lift properly and prevent injury to operators or objects. This manual has been written to be used by shop technicians in charge of the lift (operator) and routine maintenance technician (maintenance operator).

The operating instructions are considered to be an integral part of the machine and must remain with it for its whole useful life. Read every section of this manual carefully before operating the lift and unpacking it since it gives helpful information about:

- **safety of people**
- **safety of the lift**
- **safety of lifted vehicles**

The company is not liable for possible problems, damage, accidents, etc. resulting from failure to follow the instructions contained in this manual.

Only skilled technicians of AUTHORISED DEALERS or SERVICE CENTERS AUTHORIZED by the manufacturer shall be allowed to carry out lifting, transport, assembling, installation, adjustment, calibration, settings, extraordinary maintenance, repairs, overhauling and dismantling of the lift.

The manufacturer is not responsible for possible damage to people, vehicles or objects if said operations are carried out by unauthorized personnel or the lift is improperly used.

Any use of the machine made by operators who are not familiar with the instructions and procedures contained herein shall be forbidden.

1.1 Manual Keeping

For a proper use of this manual, the following is recommended:

- Keep the manual near the lift, in an easily accessible place.
- Keep the manual in an area protected from the damp.
- Use this manual properly without damaging it.
- Any use of the machine made by operators who are not familiar with the instructions and procedures contained herein shall be forbidden.

This manual is an integral part of the lift: it shall be given to the new owner if and when the lift is resold.

1.2 Obligation In Case Of Malfunction

	In case of machine malfunction, follow the instructions contained in the following chapters.
---	---

1.3 Cautions For The Safety Of The Operator

Operators must not be under the influence of sedatives, drugs or alcohol when operating the machine.

	Before operating the lift, operators must be familiar with the position and function of all controls, as well as with the machine features shown in the chapter "Operation and use"
---	--

1.4 Warnings

	Unauthorized changes and/or modifications to the machine relieve the manufacturer of any liability for possible damages to objects or people. Do not remove or make inoperative the safety devices, this would cause a violation of safety at work laws and regulations.
---	---

	Any other use which differs from that provided for by the manufacturer of the machine is strictly forbidden.
---	---

	The use of non genuine parts may cause damage to people or objects
---	---

1.5 Scrapping

When your machine's working life is over and it can no longer be used, it must be made inoperative by removing any connection to power sources.

These units are considered as special waste material, and should be broken down into uniform parts and disposed of in compliance with current laws and regulations.

If the packing are not polluting or non-biodegradable, deliver them to appropriate handling station.

Declaration Of Warranty And Limitation Of Liability

The manufacturer has paid proper attention to the preparation of this manual. However, nothing contained herein modifies or alters, in any way, the terms and conditions of manufacturer agreement by which this lift was acquired, nor increase, in any way, manufacturer's liability to the customer.

To The Reader

Every effort has been made to ensure that the information contained in this manual is correct, complete and up-to date. The manufacturer is not liable for any mistakes made when drawing up this manual and reserves the right to make any changes due the development of the product, at any time.

Product Identification

The identification data of the machine are shown in the serial plate placed on the power side column.



The removal of the serial plate is strictly forbidden.

Machines may be updated or slightly modified from an aesthetic point of view and, as a consequence, they may present different features from these shown, this without prejudicing what has been described herein.

2.1 Warranty Certificate

The warranty is valid for a period of 12 months starting from the date of the purchase invoice.

The warranty will come immediately to an end when unauthorized modifications to the machine or parts of it are carried out.

The presence of defects in workmanship must be verified by the Manufacturer's personnel in charge.

2.2 Technical Servicing

For all servicing and maintenance operations not specified or shown in these instructions, contact your Dealer where the machine has been bought or the Manufacturer's Commercial Department. Only skilled personnel who are familiar with the lift and this manual shall be allowed to carry out packing, lifting, handling, transport and unpacking operations.

Packing / Transport / Storage

3.1 Packing

The packing of the lift is shown in the figure 1: N. 1 base unit packed in a steel frame, wrapped up in non-scratch material, including all accessories and the package of power unit.

The package weight is about *4100 lbs.*

If requested, optional accessories are available to satisfy each customer's requirements.

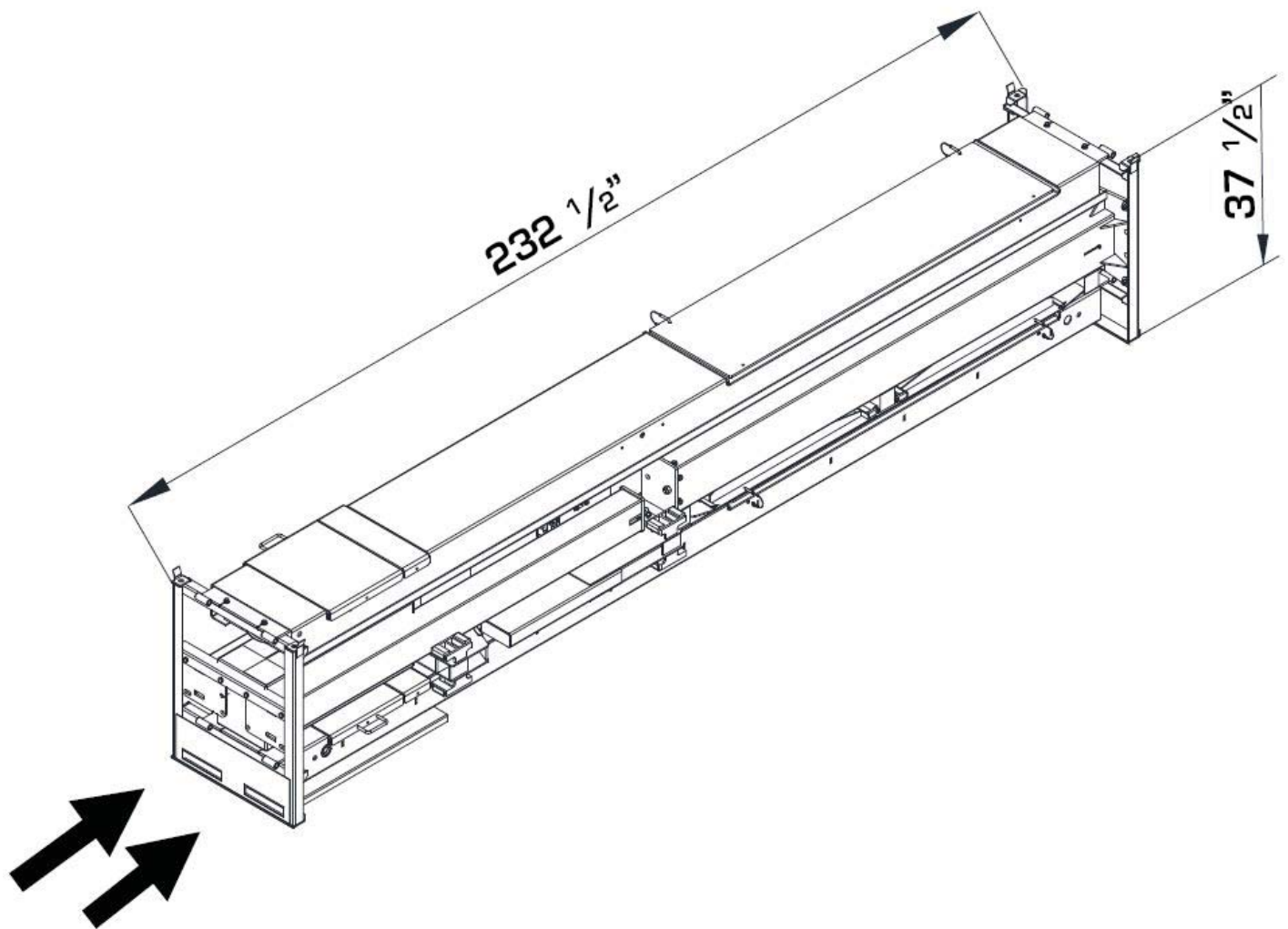

Figure 1 – Package

3.2 Lifting And Handling

When loading/unloading or transporting the equipment to the site, be sure to use suitable loading (e.g. cranes, trucks) and hoisting means. Be sure also to hoist and transport the components securely so that they cannot drop, taking into consideration the package's size, weight and centre of gravity and its fragile parts.

3.3 Storage And Stacking Of Packages

Packages must be stored in a covered place, out of direct sunlight and in low humidity, at a temperature between -10°C and +40°C.

Stacking is not recommended: the package's narrow base, as well as its considerable weight and size make it difficult and hazardous.

3.4 Delivery And Check Of Packages

When the lift is delivered, check for possible damages due to transport and storage; verify that what is specified in the manufacturer's confirmation of order is included. In case of damage in transit, the customer must immediately inform the carrier of the problem.

Packages must be opened paying attention not to cause damage to people (keep a safe distance when opening straps) and parts of the lift (be careful the objects do not drop from the package when opening).

Product Description

The lift is suitable for lifting motor vehicles having maximum weight as described in the nameplate on the power side column of the lift. All mechanical parts have been built in steel plate to make the frame stiff and strong while keeping a low weight. The electro hydraulic operation is described in detail in chapter 8.

This chapter describes the lift's principal elements, allowing the user to be familiar with the machine. As shown in figure 2, the lift is composed of four columns: N.2 front columns (1), N.2 rear columns (2), two platforms: the power-side platform (3) with the hydraulic cylinder included and the off-side platform (4), and two beams: the front beam (5) and the rear beam (6), anchored to the ground by means of the column base plates. Raising motion is carried out by pushing the lifting button on the power unit (7) to operate a power unit delivering the hydraulic fluid to cylinders to act on cable lifting system. Lowering motion is controlled by pushing the lowering lever on the power unit and carried out under the weight of the load lifted. The automatic mechanical back-up safety (8) holds on the lift in the elevated position, can be released by pushing the lever of the control valve (9). The slack cable safety (10) can hold on the lift in event of cable slackening and/or failure.

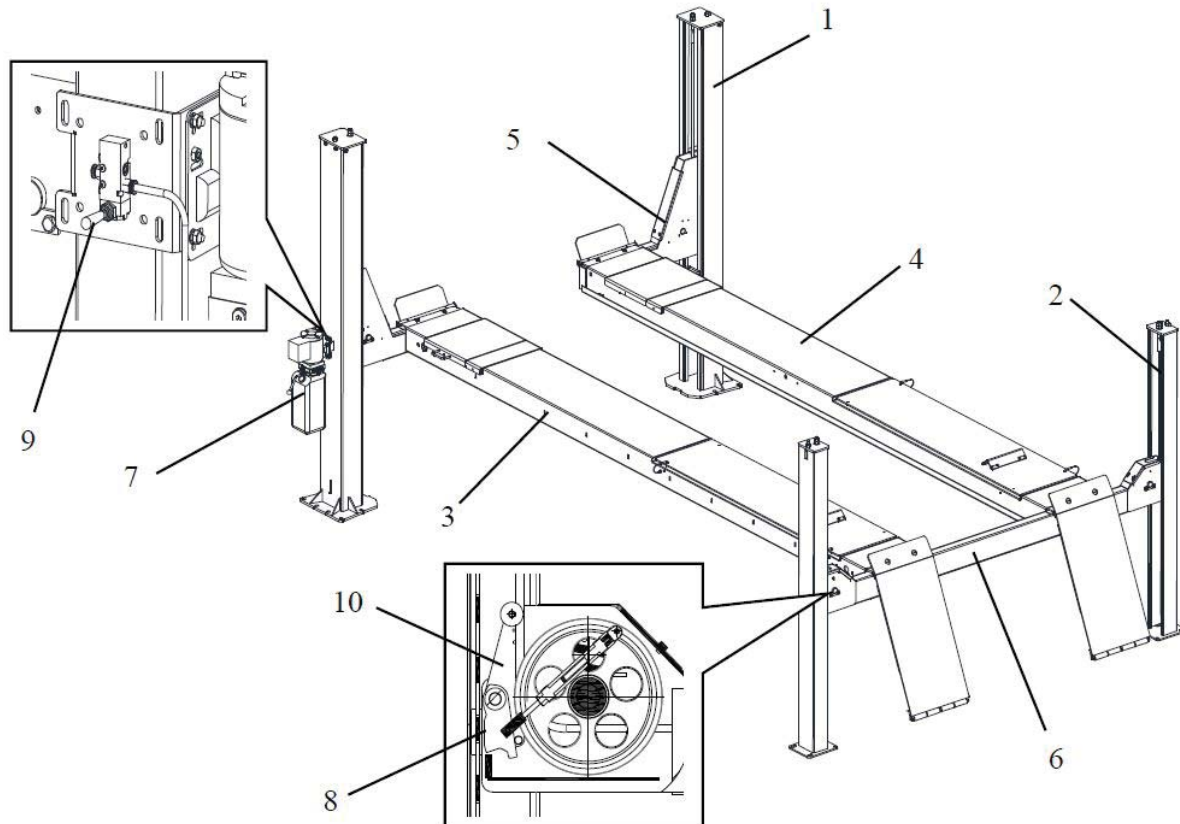

Figure 2 – Lift

Technical Specification

5.1 Size And Main Features

LIFT CAPACITY	14,000lbs (6400kg)
Maximum raised height	76 3/4" (1950mm)
Min. lowered height	7 7/8" (200mm)
Runway length	223 1/2" (5679mm)
Runway width	20" (510mm)
Free width between runways	42 3/4" (1086mm)
Width between two columns	116 3/8" (2955mm)
Max. overall length	272 1/8" (6913mm)
Overall height	109 1/4" (2775mm)
Overall width	140 1/8" (3559mm)
Raised time	66s
Noise level	80 dB(A)/1m
Rated pneumatic pressure	6bar – 8bar
Working temperature	5 °C - 40 °C
Average weight of package	4400 lbs (2000kg)

5.2 Electric Motor

Voltage	208V-240V/50Hz/60Hz/1Ph
Power	2HP
N° Poles	2
Speed	2880/3450 rpm
Motor enclosure type	B14
Insulation class	IP 54

Motor connection must be carried out referring to the attached wiring diagrams (fig.6). The motor direction of rotation is shown in the label placed on the motor. Before use of the lift, make sure to check if the motor specification shown in the nameplate of the motor conforms to the local electric supply.

5.3 Pump

Type	Gear
Flow rate	2.5 cm ³ /g
Continuous working pressure	160 bar

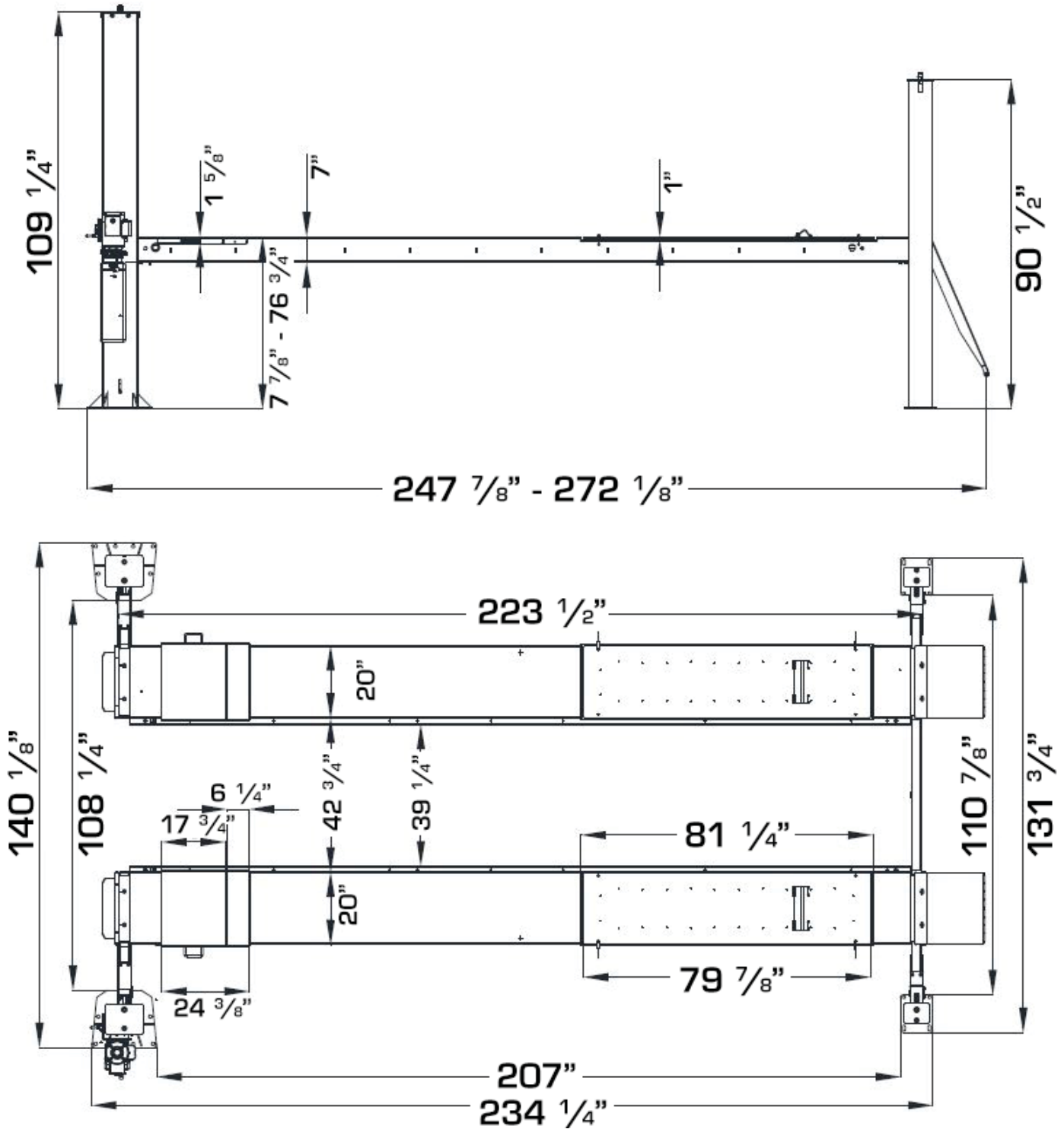

Figure 3 – Lift Layout

5.4 Hydraulic Power Unit

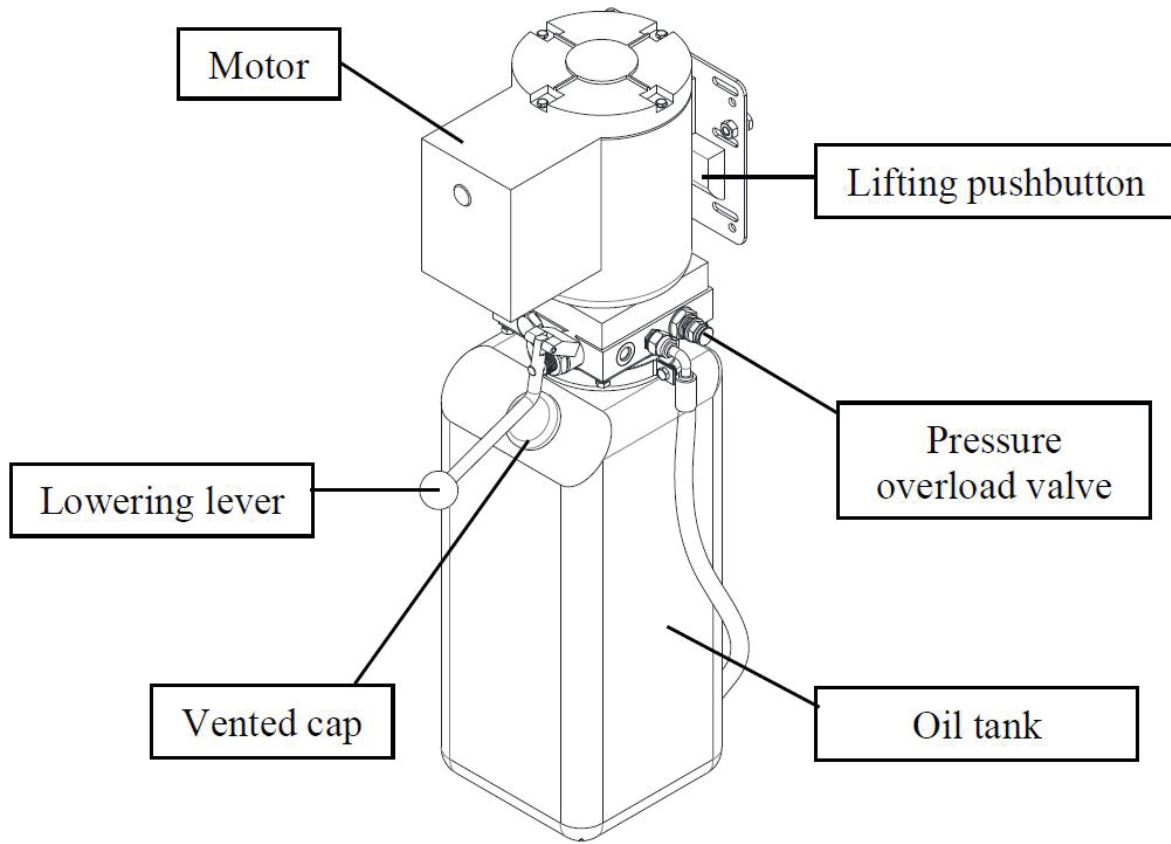

Figure 4 – Hydraulic Power Unit

5.5 Oil

Use wear proof oil for hydraulic drive, in conformity with *ISO 6743/4* rules (HM class). The oil with features similar to those shown in the table is recommended.

Test standards	Features	Value
ASTM D 1298	Density 20°C	0.8 kg/l
ASTM D 445	Viscosity 40°C	32 cSt
ASTM D 445	Viscosity 100°C	5.43 cSt
ASTM D 2270	Viscosity index	104 N°
ASTM D 97	Pour point	~ 30 °C
ASTM D 92	Flash point	215 °C
ASTM D 644	Neutralization number	0.5 mg KOH/g

 **Change hydraulic oil at 1 year intervals**

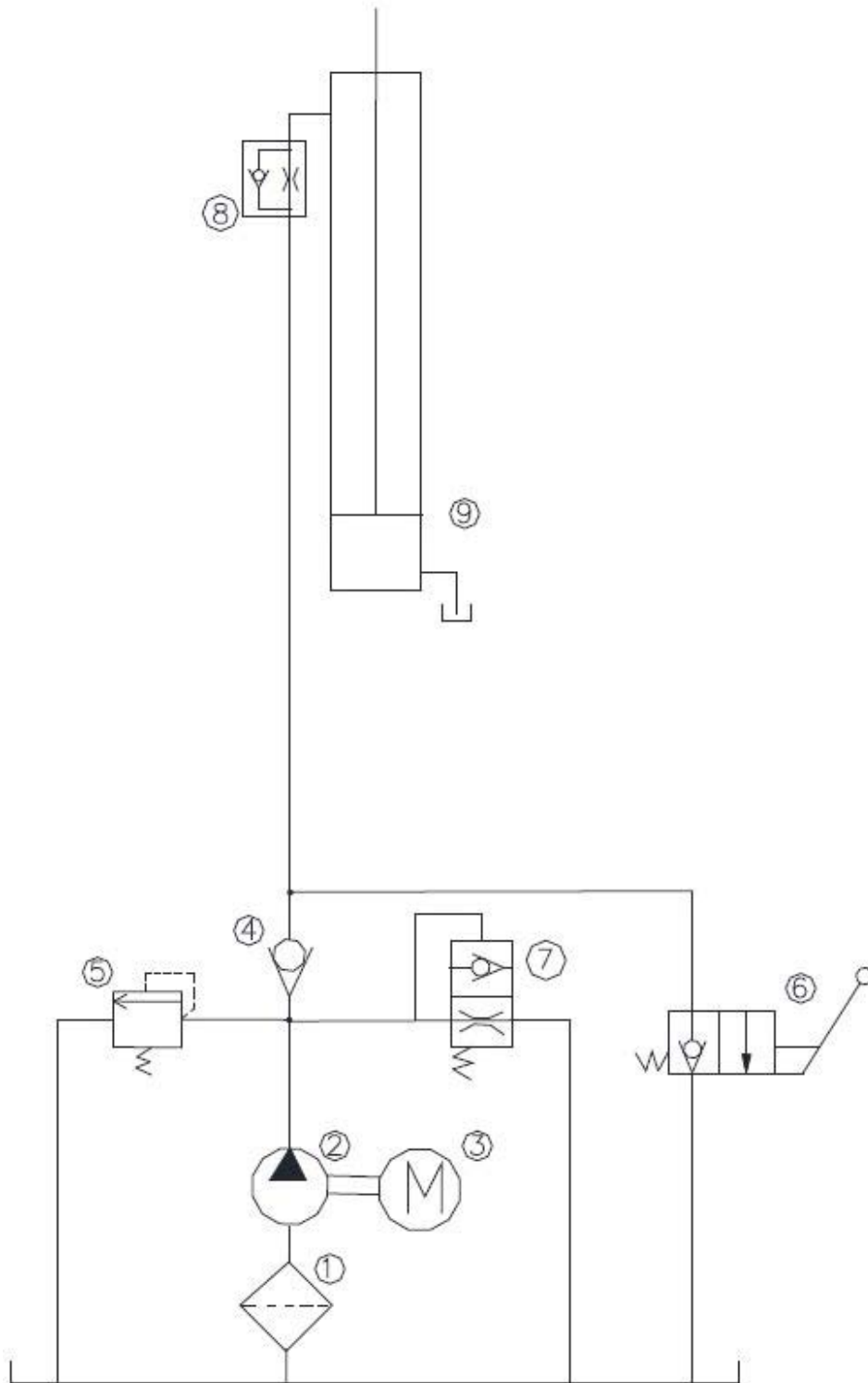

Figure 5 -Hydraulic Plan

1	Oil filter	6	Manual lowering valve
2	Gear pump	7	Startup valve
3	Motor	8	Flow restrictor
4	Non return valve	9	Hydraulic cylinder
5	Pressure overload valve		

WIRING INSTRUCTIONS

To install power unit without relay:

Connect L1 incoming power line to black pushbutton switch wire #9.

Connect L2 incoming power line to white motor wire #5.

Connect incoming green ground wire to green ground motor wire.

If using overhead switch:

Connect one overhead switch wire to black switch wire #3.

Connect the other overhead wire to black motor wire #7.

If not using overhead switch:

Connect the black switch wire #3 from pushbutton switch to black motor wire #7.

To install power unit with relay:

Connect L1 incoming power line to black relay wire #6 & black pushbutton wire #9.

Connect L2 incoming power line to white relay wire #2

Connect incoming green ground wire to green ground motor wire.

Connect white relay #4 to white motor wire #5.

Connect black relay wire #8 to black motor wire #7.

If using overhead switch:

Connect one overhead switch wire to black switch wire #3

Connect the other overhead wire to red relay wire #1

If not using overhead switch:

Connect the black switch wire #3 from pushbutton switch to red relay wire #1.

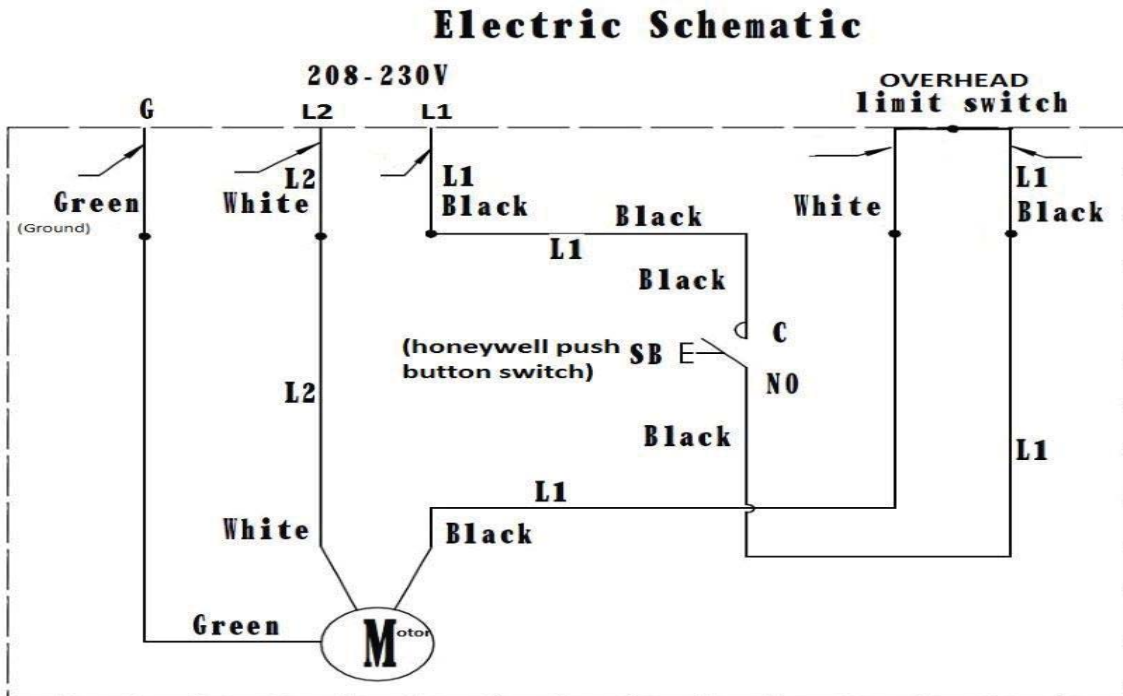

Figure 6 – Electrical Diagram (220V/50Hz/60Hz/1Ph)

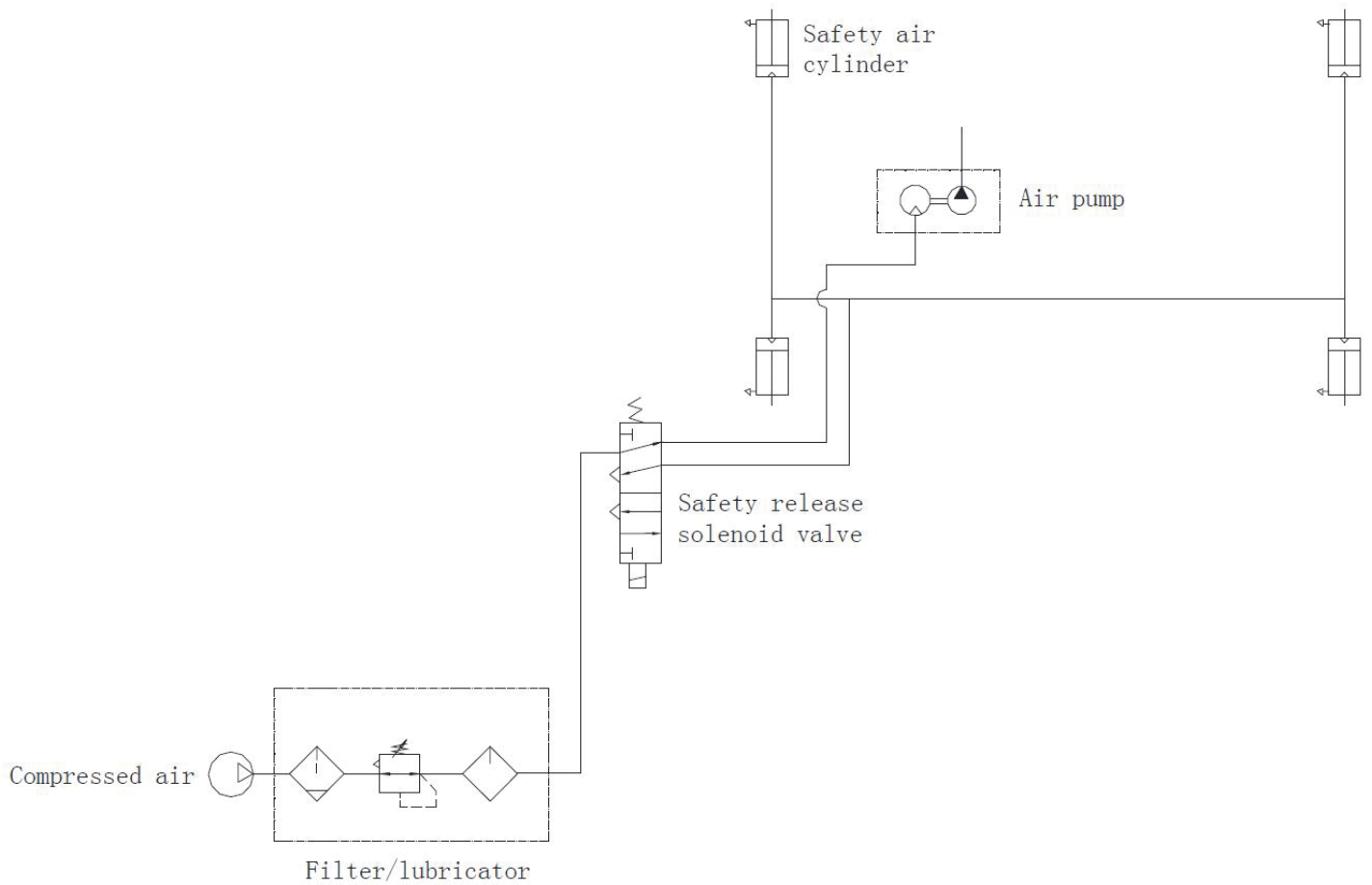



Figure 7 – Pneumatic Plan

 **Filter/regulator must be equipped on the air circuit and the air pressure is to be set at 6-8bar. Filter/regulator is not supplied by the manufacturer if no special order.**

Safety

Read this chapter carefully and completely because it contains important information for the safety of the operator and the person in charge of maintenance.



The lift has been designed and built for lifting vehicles and making them stand above level in a closed area. any other use is forbidden. The manufacturer is not liable for possible damages to people, vehicles or objects resulting from an improper or unauthorized use of the lift.

For operator and people safety, a safety area at least 1m free away from the lift must be vacated during lifting and lowering. The lift must be operated only from the operator's control site in this safety area.

Operator's presence under the vehicle, during working, is only admitted when the vehicle is lifted and runways are not running.



Never use the lift when safety devices are off-line. People, the lift and the vehicles lifted can be seriously damaged if these instructions are not followed.

6.1 General Warnings

The operator and the person in charge of maintenance must follow accident-prevention laws and rules in force in the country where the lift is installed

They also must carry out the following:

- neither remove nor disconnect hydraulic, electric or other safety devices;
- carefully follow the safety indications applied on the machine and included in the manual;
- observe the safety area during lifting;
- be sure the motor of the vehicle is off, the gear engaged and the parking brake put on;
- be sure only authorized vehicles are lifted without exceeding the maximum lifting capacity;
- Verify that no one is on the runways during lifting or standing.



Any use of the lift other than that herein specified can cause serious accidents to people in close proximity of the machine.

6.2 Risks For People

All risks the personnel could run, due to an improper use of the lift, are described in this section.

6.3 Personnel Crushing Risks

During lowering of runways and vehicles, personnel must not be within the area covered by the lowering trajectory. The operator must be sure no one is in danger before operating the lift.



Fig. 8a



Fig. 8b



Fig. 8c

6.4 Risk Of The Vehicle Falling From The Lift

Vehicle falling from the lift can be caused when the vehicle is improperly placed on platforms, and when its dimensions are incompatible with the lift or by excessive movement of the vehicle.

In this case, keep immediately away from the working area.



Fig. 9a



Fig. 9b



Fig. 9c

6.5 Slipping Risks

The risk of slipping can be caused by oil or dirt on the floor near the lift.



Keep the area under and around the lift clean. Remove all oil spills.

6.6 Electrocutation Risks

Avoid use of water, steam, and solvent, varnish jets in the lift area where electric cables are placed and, in particular, next to the electric panel.



Fig. 10

6.7 Risks Resulting From Improper Lighting

Make sure all areas next to the lift are well and uniformly lit, according to local regulations.

6.8 Risks Of Breaking Component During Operation

Materials and procedures, suitable for the designed parameters of the lift, have been used by the manufacturer to build a safe and reliable product. Operate the lift only for the use it has been designed for and follow the maintenance schedule shown in the chapter "Maintenance".



Fig. 11

6.9 Risks For Unauthorized Uses

The presence of unauthorized persons next to the lift and on the platforms is strictly forbidden during lifting as well as when the vehicle has been already lifted.



Fig. 12

6.10 Risks During Vehicle Lifting And Working

To avoid overloading and possible breaking during lifting and working, the following safety devices have been used:

- A pressure valve placed inside the hydraulic unit to prevent excessive weight.



The maximum pressure valve has been preset by the manufacturer to a proper pressure. DO NOT try to adjust it to overrun the rated lifting capacity.

- Automatic mechanical back-up safety holds on the lift in the elevated position.
- Slack safety in event of cable slackening and/or failure.



It is strictly forbidden to modify any safety device. Always ensure the safety device for proper operation during the service.

Installation



Only skilled technicians, appointed by the manufacturer, or by authorized dealers, must be allowed to carry out installation. Serious damage to people and to the lift can be caused if installations are made by unskilled personnel. Always refer to the exploded views attached during installation.

7.1 Tool Required

• Rotary Hammer Drill D.16	• Hex-Key/Allen Wrench Set
• Masonry Bit	• Crow Bar For Shim Installation
• Hammer	• Chalk Line
• Level	• Medium Cross Screwdriver
• Open-End Wrench Set	• Medium Flat Screwdriver
• Medium Crescent Wrench	• Tape measure

7.2 Checking For Room Suitability

The lift has been designed to be used in covered and sheltered places. The place of installation must not be next to washing areas, painting workbenches, solvent or varnish deposits. The installation near to rooms, where a dangerous situation of explosion can occur, is strictly forbidden. The relevant standards of the local Health and Safety at Work regulations, for instance, with respect to minimum distance to wall or other equipment, must be observed.

7.3 Lighting

Lighting must be carried out according to the effective regulations of the place of installation. All areas next to the lift must be well and uniformly lit.

7.4 Installation Surface

The lift MUST be installed on 3000 PSI concrete with the minimum thickness 6" and an extension of at least 1.5m from anchoring points.

New concrete must be adequately cured by at least 21 days minimum.

	<p>A level floor is suggested for proper installation. Small differences in floor slope may be compensated for by proper shimming. Any major slope change will affect the level lifting performance. If a floor is of questionable slope (more than 3 degrees), considering to pour the new concrete slab.</p>
---	---

7.5 Positioning Lift

- Determine which end of the lift will be approach side.
- Determine which side the power-side runway (with the hydraulic cylinder attached) will be located on. Remember that the power-side runway must be installed on the same side as the power-side column.

7.6 Attaching Runways To Rear Beam

	<p>It is important to position the power-side runway (with the hydraulic cylinder) on the same side as the power unit location. Elevate runways off the floor with blocks of wood to prevent any damage.</p>
---	---

- Position the runways in the predetermined location. Pay attention that the rails on each side must be installed to the inside. Cables and pulleys are pre-assembled in the power-side runway but not in the off-side runway.
- Position the rear beam at end of the runways. Make sure the opening of the beam should be lined up with the pulleys in the runway end.
- Slide the cable ends from the end of power-side runway.
- Assemble the pulleys, bearings and other accessories into both ends of the off-side runway as shown in fig.15.
- Route the cable ends through the beam openings as shown in fig.13 and fig.14. Make sure that the cables are not twisted and routed on the correct pulleys in runways. Make sure to route the cables through the retainer before attaching them to the holder. Do not assemble the cable pulleys in the beam ends at this time.

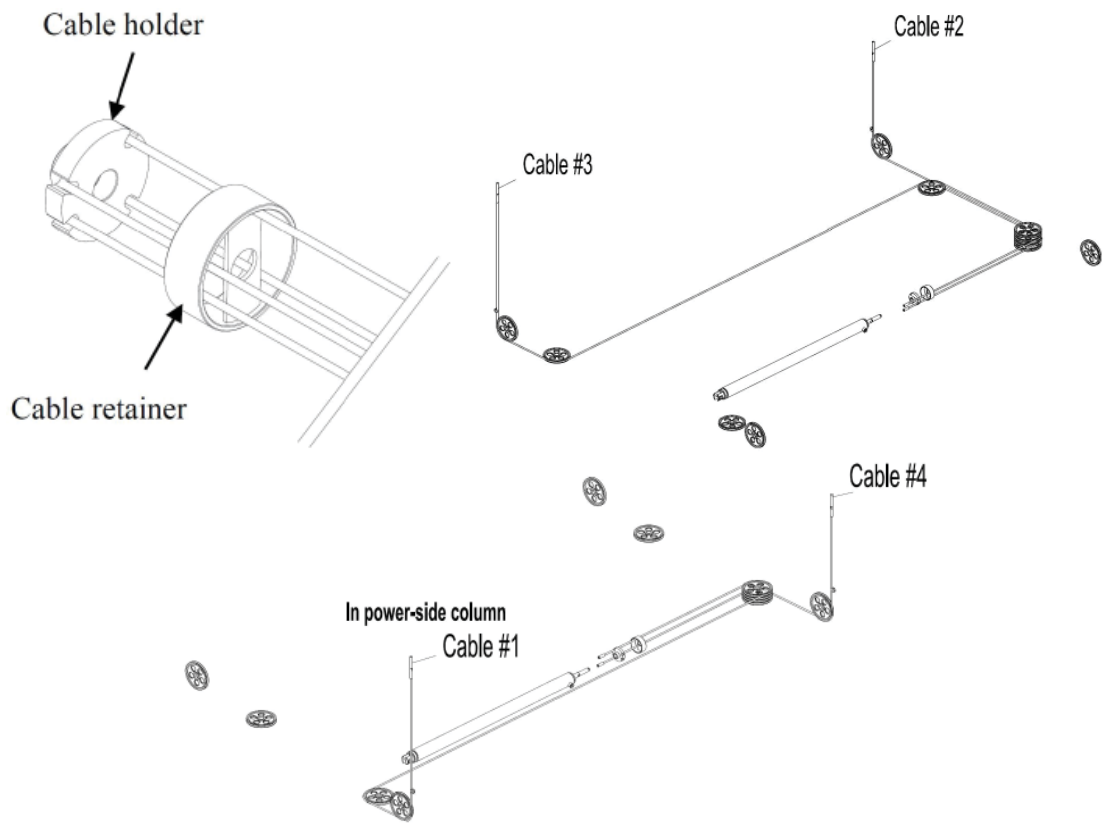
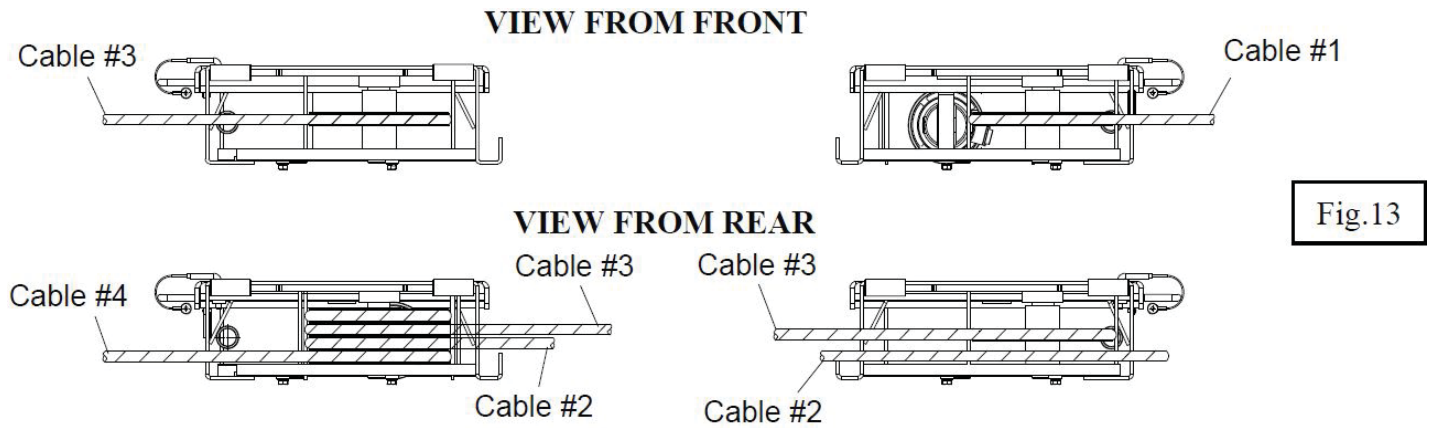
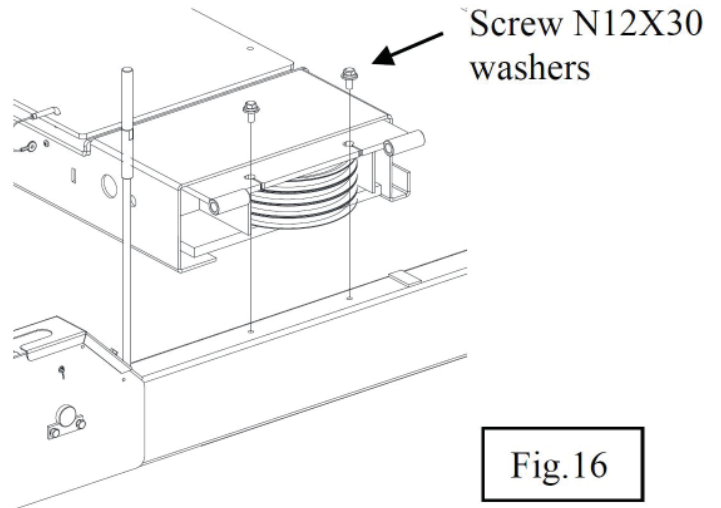
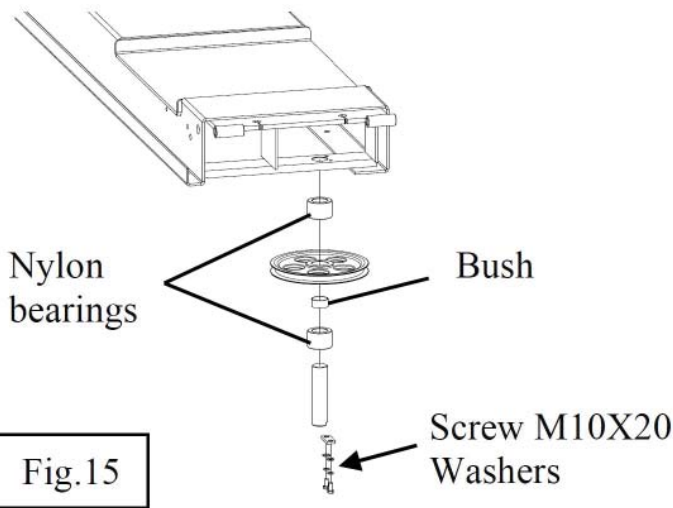

Figure 14 – Cable Routing Diagram

- With the openings in the rear beam side lined up with the runway ends, align the bolt holes in top of the beam with the slots in the runway ends. Bolt the runway to the rear beam using screws and washers as shown in fig. 16.



7.7 Attaching Rear Columns To Rear Beam

- Position a rear columns to the rear corner of the lift.
- Place the latch rack into the back of the column as shown in fig.17. Pay attention that the latch rack is offset from the center line of the thread stud. It should be oriented toward the back of the column from the center line of the thread stud.
- Insert the thread stud of the latch rack through the hole of the top plate and fit two M20 nuts into the thread stud of the latch rack. Adjust the nuts down the thread stud until the nut and the top plate are flush.
- Install the pulley and the nylon spacers on the rear beam as shown in fig.18.
- Raise the latch rack above the sliders as shown in fig.19 and move the column toward the rear beam until the sliders contact the back of the column.
- Lower the latch rack into the sliders as shown in fig.19.
- Adjust the nuts on the thread stud of the latch rack against the column top plate so that the latch rack should engage the sliders for at least 25mm when the lift is lowered completely.
- Repeat the above procedures to attach another rear column to the rear beam.

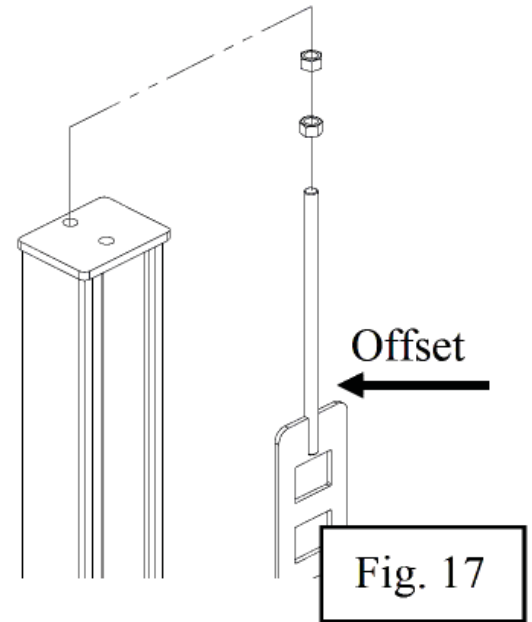

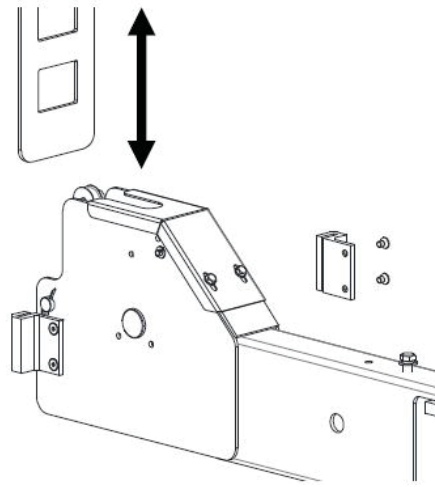
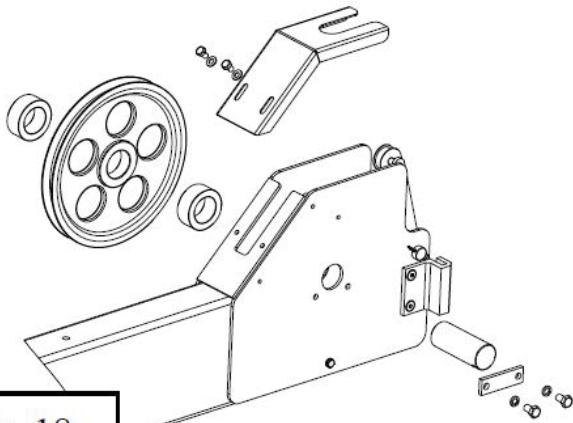

Make sure each cable is routed in the pulley groove following the roping diagram fig. 14. Failure to install the nylon bearings and bearings in the runways and beams will result in premature failure and void the warranty.

7.8 Attaching Front Columns To Front Beams

- Position front columns to the rear corner of the lift.
- Place the latch rack into the back of the column. Pay attention that the latch rack is offset from the center line of the thread stud. It should be oriented toward the back of the column from the center line of the thread stud.
- Secure the bottom of the latch rack to the column as shown in fig.20.
- Install the top plate onto the column using screws as shown in fig.21. Tighten the screws and nuts.
- Insert the thread stud of the latch rack through the hole of the top plate and fit two M20 nuts into the thread stud of the latch rack. Adjust the nuts down the thread stud until the nut and the top plate are flush.
- Lay the column down with back to the floor.

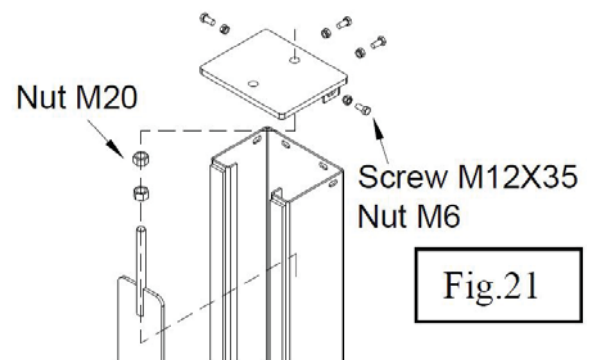
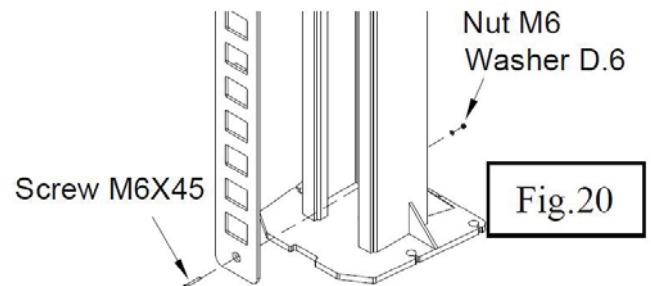

- Slide the beam through the top opening of the column to the bottom of the column. Make sure that all sliders shown in the fig.22 are in position.
- Raise the beam and column assembly to the upright position and slide the beam under the runway end. Make sure the opening of the beam should be lined up with the pulleys in the runway end.
- If the beam is not level with the column, put the shims between the carriage and the block to make the beam level as shown in fig.22a.
- Slide the cable ends through the opening of the beam.
- Align the bolt holes in top of the beam with the slots in the runway ends. Bolt the runway to the rear beam using screws and washers as shown in fig.22.
- Repeat the above procedures to attach another front column to the runway.

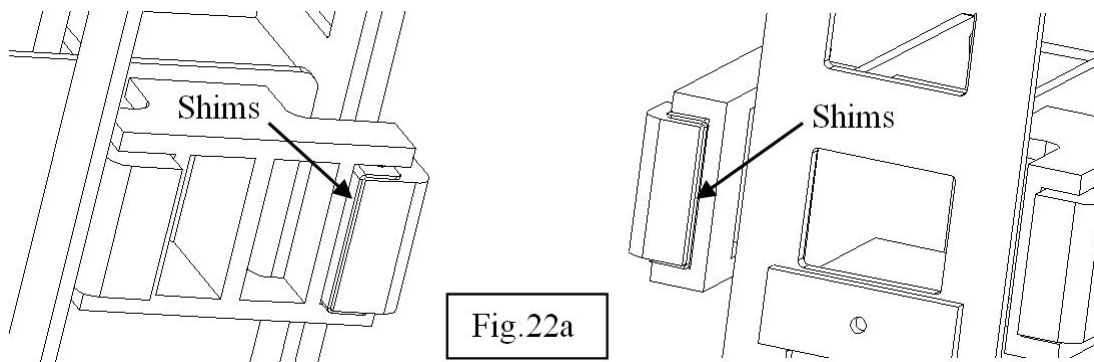
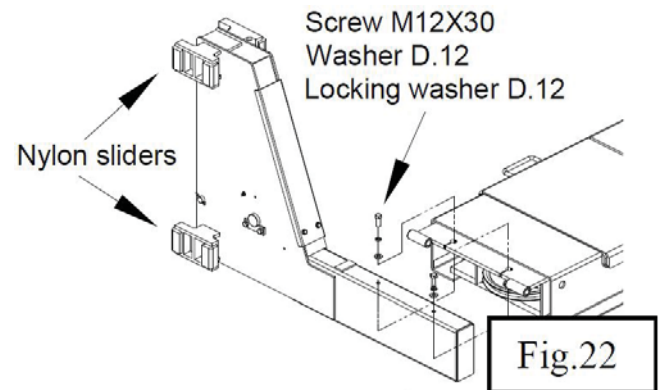

7.9 Installation Of Front Pulleys And Cables

- Assemble the pulleys, bearings, pulley cover and other accessories into the front beams as shown in fig.23.
- Install each cable to the column top plate using the nuts and washers as shown in fig. 24.

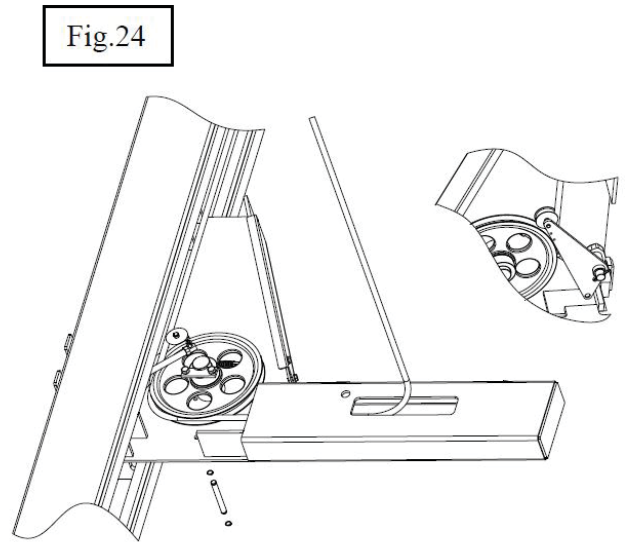
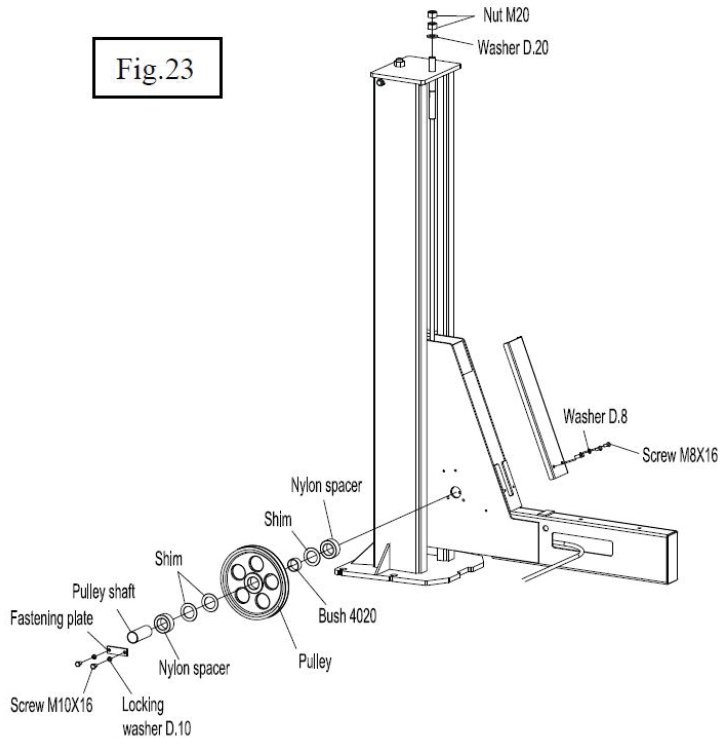

7.10 Anchoring Columns

- Before proceeding, install the space bar and bolt it on the runways as shown in fig. 25 to help maintain the runway spacing. Adjust runways until the diagonals are equal. Check the measurement referring to the fig.26 and make sure to keep columns square to the center line of lift.

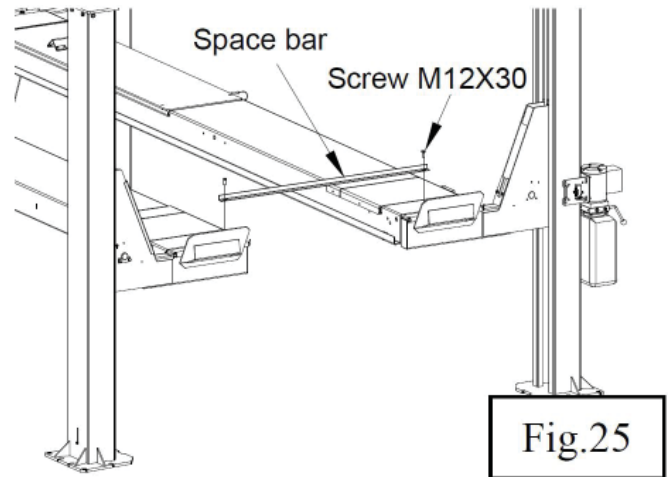

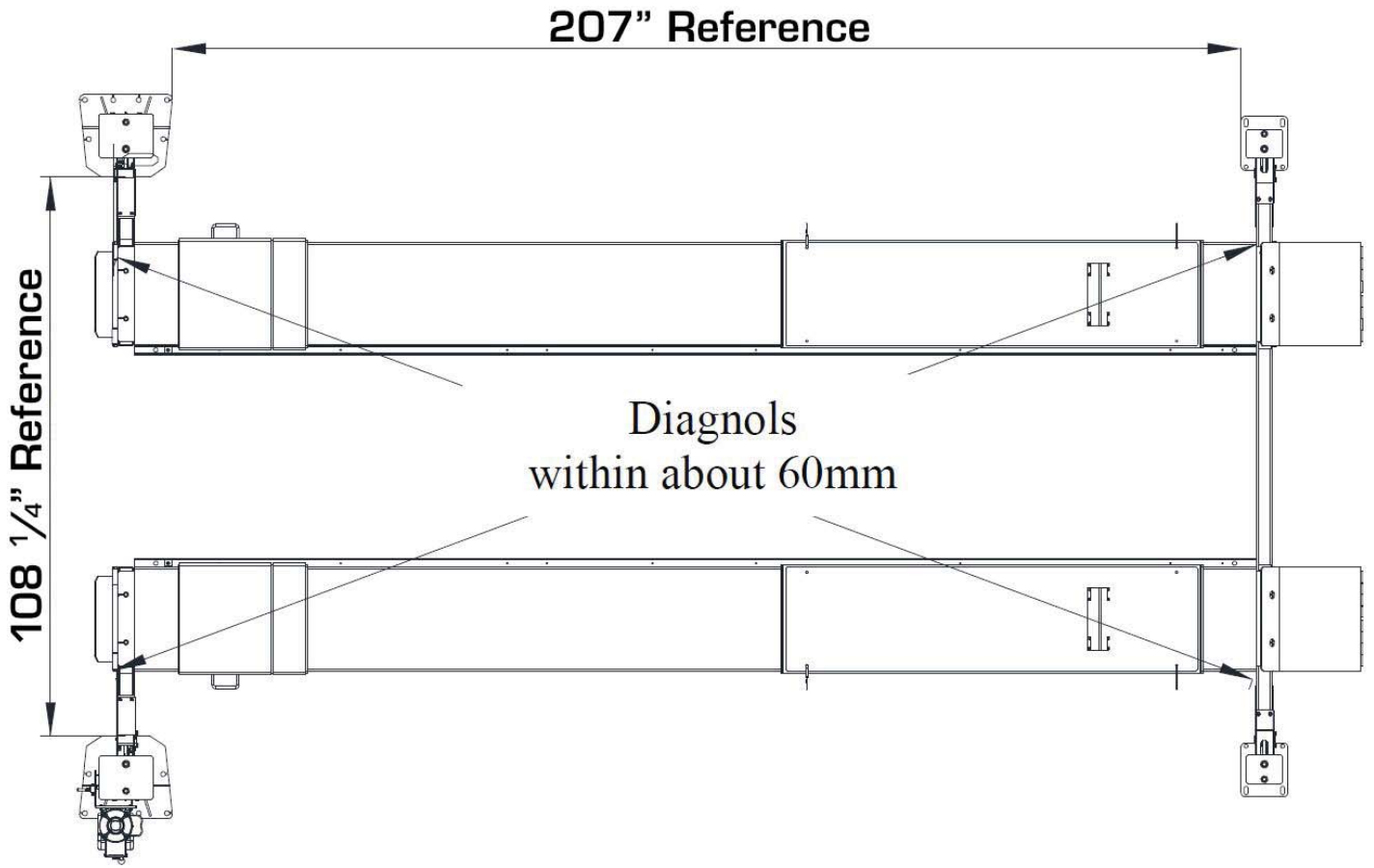

Figure 26 – Square And Diagonal Measurement

7.10.1 Anchoring Rear Columns

- Move a rear column towards the rear beam until the sliders contact the back of column. Center the beam in the column.
- Using the base plate as guide, drill each hole in the concrete approximately 120mm deep with the rotary hammer drill D.16.
- Assemble the washers and nuts on the anchors then tap into each hole with a hammer until the washer rests against the base plate. Be sure if shimming is required, enough threads are left exposed.
- If shimming is required, insert the shims as necessary around the anchor bolts. Check the columns for plumb. Re-shim if necessary
- With the shims and anchor bolts in place, tighten by securing the nut to the base.
- Repeat the above procedures for another column.

7.10.2 Anchoring Front Columns

- If necessary, readjust the runways until the diagonals are equal.
- Repeat the same procedures above for rear columns to anchor the front columns.

7.11 Installation Of Power Unit

- Attach the power unit onto the bracket on the power side column.
- Secure it using M8X25 screws, M8 nuts and the washers.
- Make sure to keep the power unit clean.

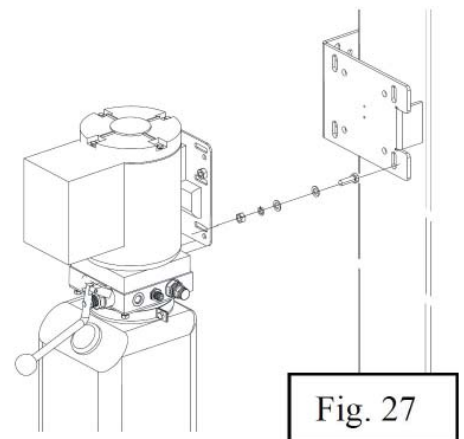

7.12 Connection Of Hydraulic Hoses



When routing the hydraulic hose, make sure that the hose is clear of any moving part, make sure to keep the hose and fittings clean from dust.

- Clean the hoses and fittings.
- Inspect all threads for damage and make sure that all hose fittings are in good condition.
- Route the hoses as shown.
- Tighten the hose fittings thoroughly. Make sure not to over-tighten the hose fittings so as to result in oil leakage.

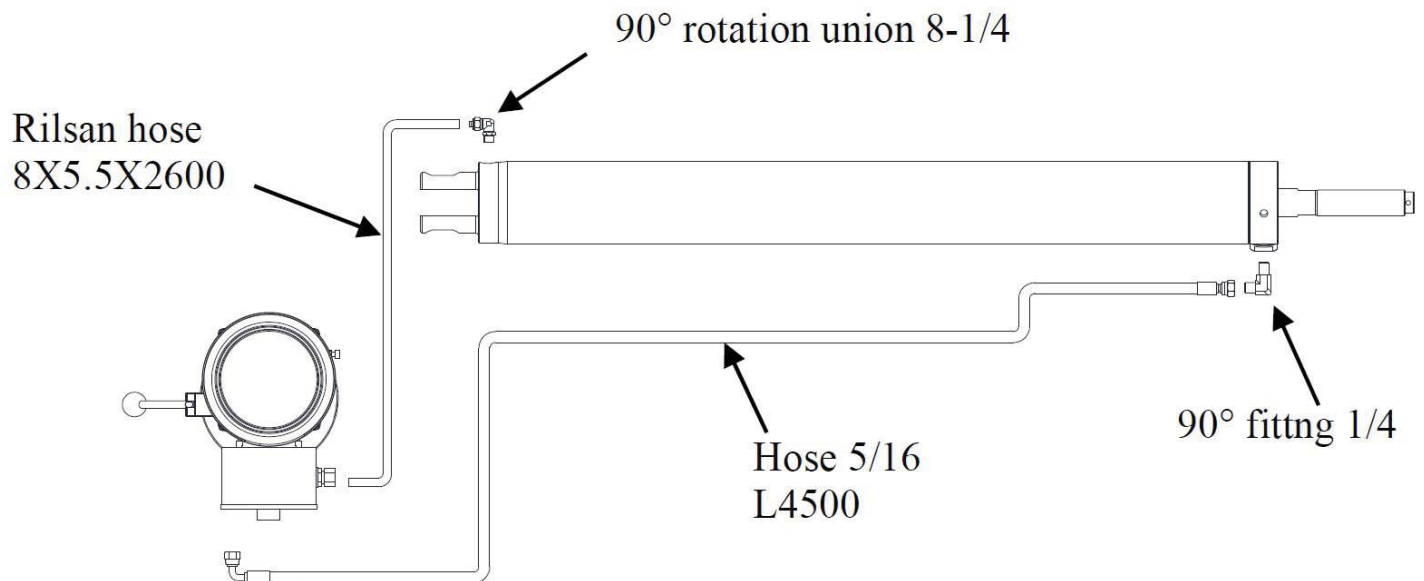

Figure 28 – Hydraulic Line Connection

7.13 Pneumatic System Connection



The air hose must be cut square with no burrs.

When routing the air tubes, make sure that the tubes are clear of any moving part. It may necessary to tie the hoses clear by using nylon tie straps or wire.

Filter/regulator must be equipped on the air circuit and the air pressure is to be set at 6-8bar.

The pneumatic supply at site (to which the pneumatic system of the lift is connected) must be equipped with a servicing unit composed of water separator, lubricator and pressure reducer. These devices can be supplied by the manufacturer on request.

For the connection of the pneumatic lines proceed as follow:

- Install the control valve on the motor bracket using screws M4X30 (ref. fig. 29).
- Connect the pneumatic lines referring to the diagram (fig.30);
- Connect the air valve to the pneumatic supply at site.
- Check for the air leaks by depressing the air valve.

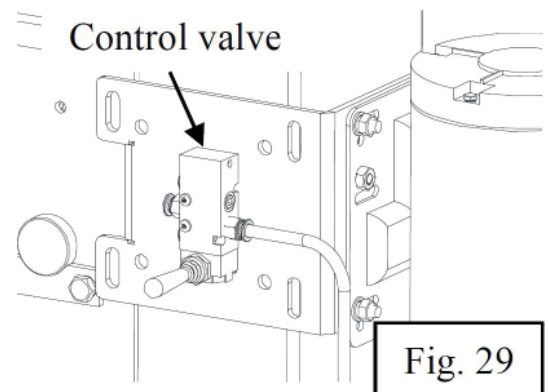

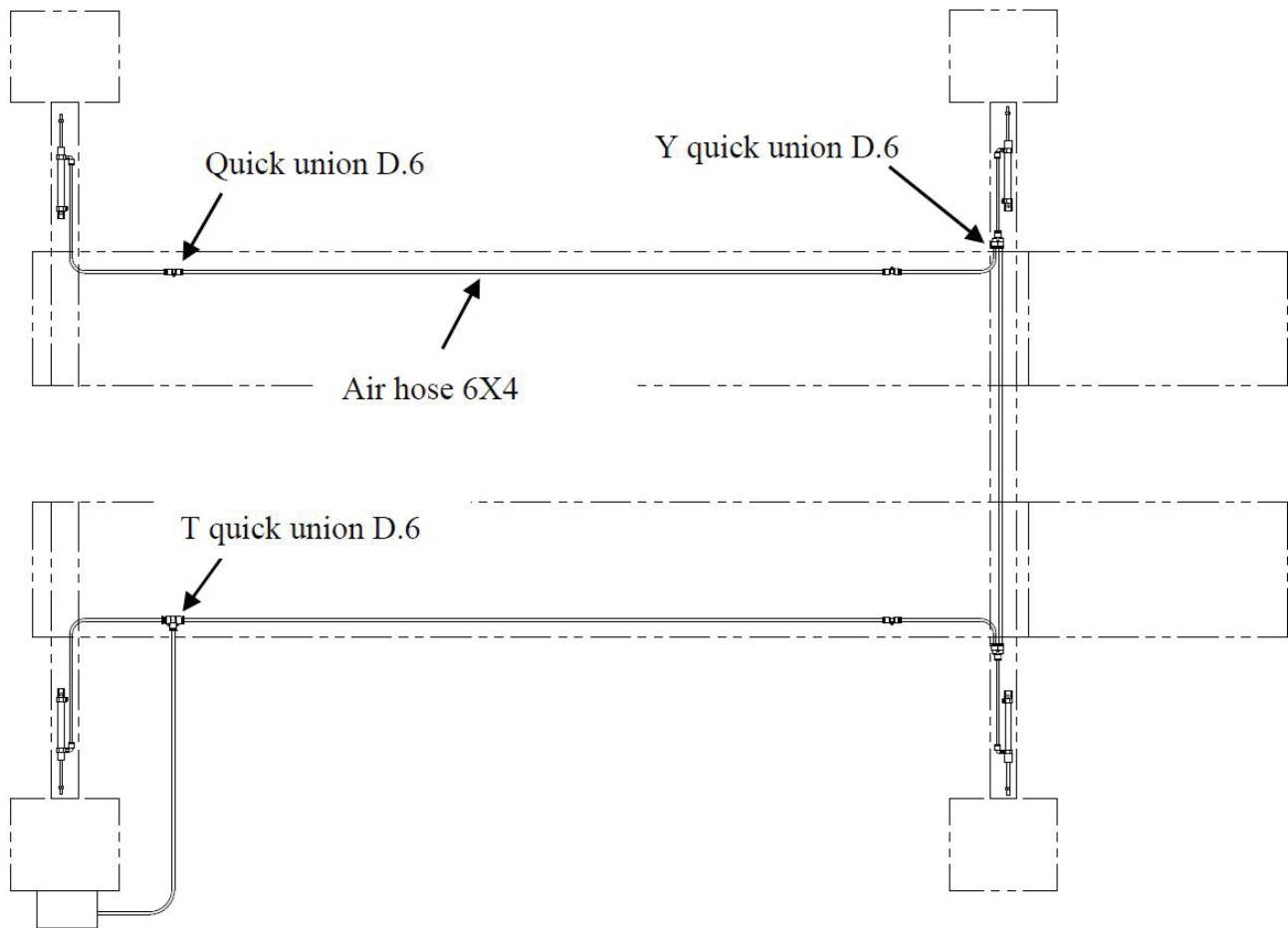



Figure 30 – Pneumatic Connection Diagram

7.14 Make The Electrical Hookup To The Power Unit

	<p>The hookup work must be carried out by a qualified electrician. Make sure that the power supply is right. Make sure the connection of the phases is right. The power unit must be kept dry.</p>
---	---

	<p>It is strictly forbidden to use 60Hz motor on 50Hz power supply. Never operate the motor on the power less than 208V. Motor damage may occur.</p>
---	---

- Make the electric hookup to the hydraulic power unit referring to the wiring diagram (fig. 6);
- Make sure to install a proper circuit breaker on the circuit (DZ47-63/ D32A/2P is suggested for single phase 208-240V).
- Make sure the lift is grounded well.

7.15 Oil Filling And Bleeding



DO NOT run power unit with no oil. Damage to pump can occur.
If motor gets hot or sounds peculiar, stop immediately and recheck the electric connection.

- Use the hydraulic fluid recommended in the chapter 5.5.
- Remove the vented cap on the oil tank and pour oil in the tank about 17 liters.
- Cycle the lift up and down several times to bleed the hydraulic system until the lift is lowered smoothly. To lower the lift, latches must be released by depressing the air valve.
- Fill the more fluid if necessary till the tank is full.

7.16 Final Installation

7.16.1 Runway Leveling Adjustment



Runways must be leveled side to side, front to rear. The maximum tolerance cannot be over 1.5mm.

- Raise the lift off all latches until the cables are supporting the lift and check that all cables are adjusted in the same tension.
- Verify if both the runways are leveled horizontally by means of a water gauge or a leveling instrument. If not, readjust cables.

7.16.2 Locking Position Adjustment



All latches must be engaging uniformly before any attempt is made to work on or near the vehicle.

- Raise the lift from bottom to top and verify if all latches can be clicked into the locking positions.
- Lower the lift to the topmost latch position to verify if four latches are engaging uniformly. If not, readjust cables.

7.16.3 Accessories Installation

- Install the ramps on the rear runways using the ramp pin and two split pins 5X45 as shown in fig.31.
- Check and install all pulley covers on the corners of the beams.
- Remove the space bar from the runways.

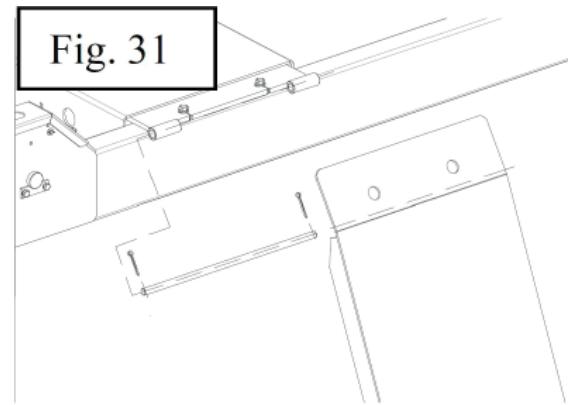

7.17 Check Before Start-Up

	<p>During START UP procedure, observe all operating components and check for proper installation and adjustment. DO NOT attempt to raise vehicle until a thorough operation check has been completed.</p>
---	--

7.17.1 General Checks

- Make sure to check that the columns are plumb;
- Make sure to check the lift anchored to the ground and all anchor bolts tightened.
- Make sure to check the electrical system feeding voltage is equal to that specified in the nameplate on the motor;
- Make sure to check the electric system connection in conformity of the electric plan shown as the electric diagram (fig. 6) and for proper grounding.
- Make sure to check all plastic sliders are on the position and greased properly.
- Make sure to check all pins are installed correctly and greased properly.
- Make sure to check all bolts, nuts and screws are tightened securely.
- Particularly, below checks must be followed:

7.17.2 Cable For Proper Installation

	<p>There will be some initial stretching of the cables in the beginning. It will be necessary to re-adjust the cables a week after the first week, then three months thereafter. Failure to do this will cause uneven lifting.</p>
---	---

- Check to make sure that all cables are routed correctly and are on the correct pulleys.
- Check that all cables are adjusted in the same tension and the lift can be raised evenly. If not, make the adjustment.

7.17.3 Safety Lock For Proper Installation

- Check to make sure that all air hoses are connected properly and the air pressure is set to 6-8bar.
- Check to make sure that the control valve for proper operation.
- Check if four latches are engaging uniformly. If not, make the adjustment.

7.17.4 Hydraulic System For Proper Operation

- Proper oil level in the tank, refill if needed.
- Raise the lift to the full height and keep the motor running for 5 seconds and check all hoses connections no leakage. Tighten the connections or reseal if necessary.
- Check the lift for reaching its maximum height.

	<p>If the vented cap is lost or broken, order the replacement. The oil tank must be vented well.</p>
---	---

7.18 Check With Load



WARNING: please follow carefully the instructions in the coming paragraph for avoiding damages on the lift.

Carried out two or three complete cycles of lowering with the vehicle loaded and lifting and:

- Repeat the checks provided for by 7.15.
- Check no strange noise during lifting and lowering.
- If the runways weren't leveled, readjust.

7.19 Installation Of Jacking Beam (Optional)

This jacking beam is designed to be equipped with a 4 post lift. The maximum capacity is 7000lbs (3200kg).

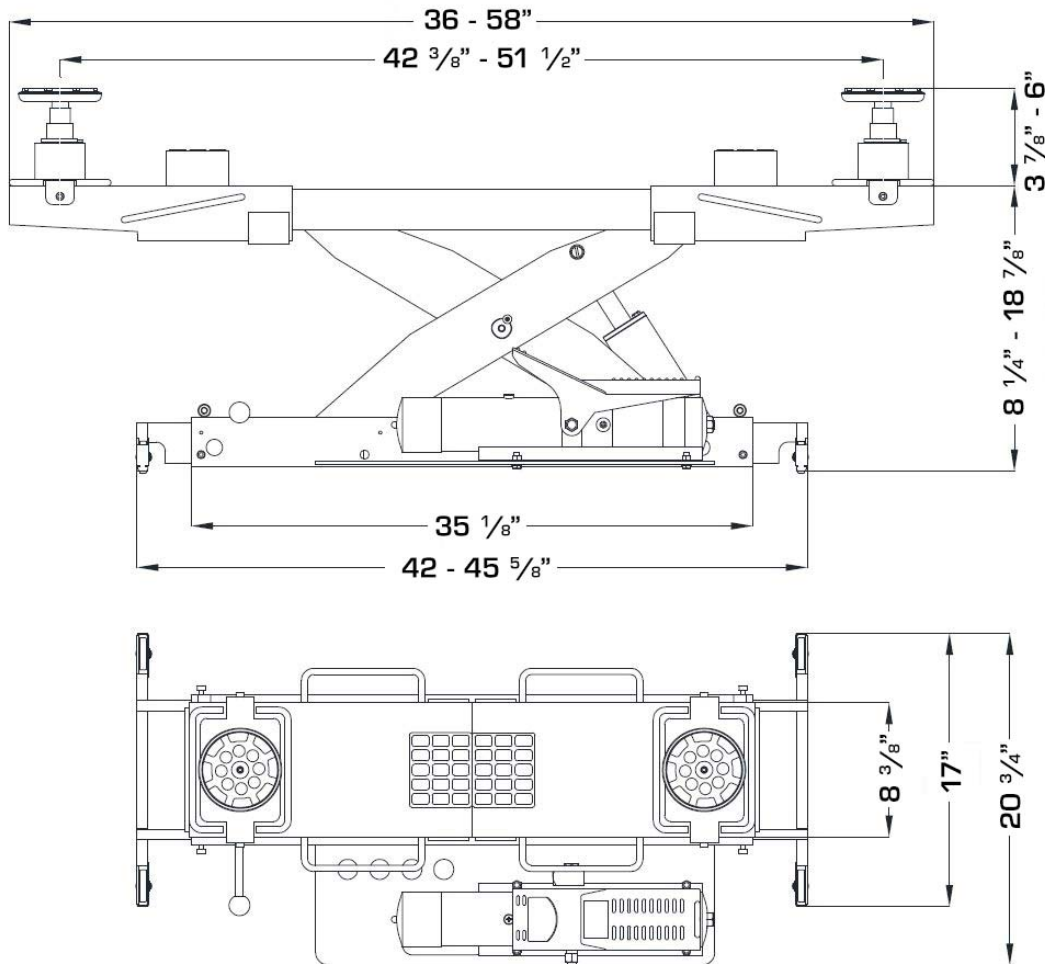

Figure 32 – Jacking Beam Layout

To install the jacking beam on a 4 post lift, do as followings.

- Lower the lift fully.
- Lower the jacking beam all the way down.
- Use a proper hoist equipment to place the jacking beam on rails inside runways of the lift.
- Adjust the base to the correct width.
- Check to make sure that all four rollers are seated properly on rails as shown in the fig.33.
- Make sure that rail channel is clean of debris.
- Raise the lift up off the ground so that the jacking beam is off the ground.
- Check the clearance and movement of the jacking beam by sliding it forward and rearward on the rails. Check all rollers are centered on the rails at all points along the rail's length. Width adjustment of the jack base may be necessary to ensure the proper operation.
- Connect the pneumatic line following the fig.7 and the instructions described in the chapter 7.13.
- Connect the hydraulic hose following the figure 34.
- Fill the pump reservoir with the oil suggested in the chapter 5.5.

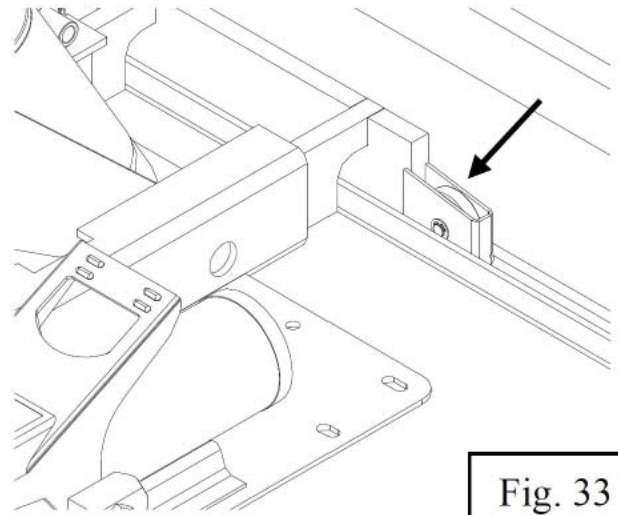

Fig. 33

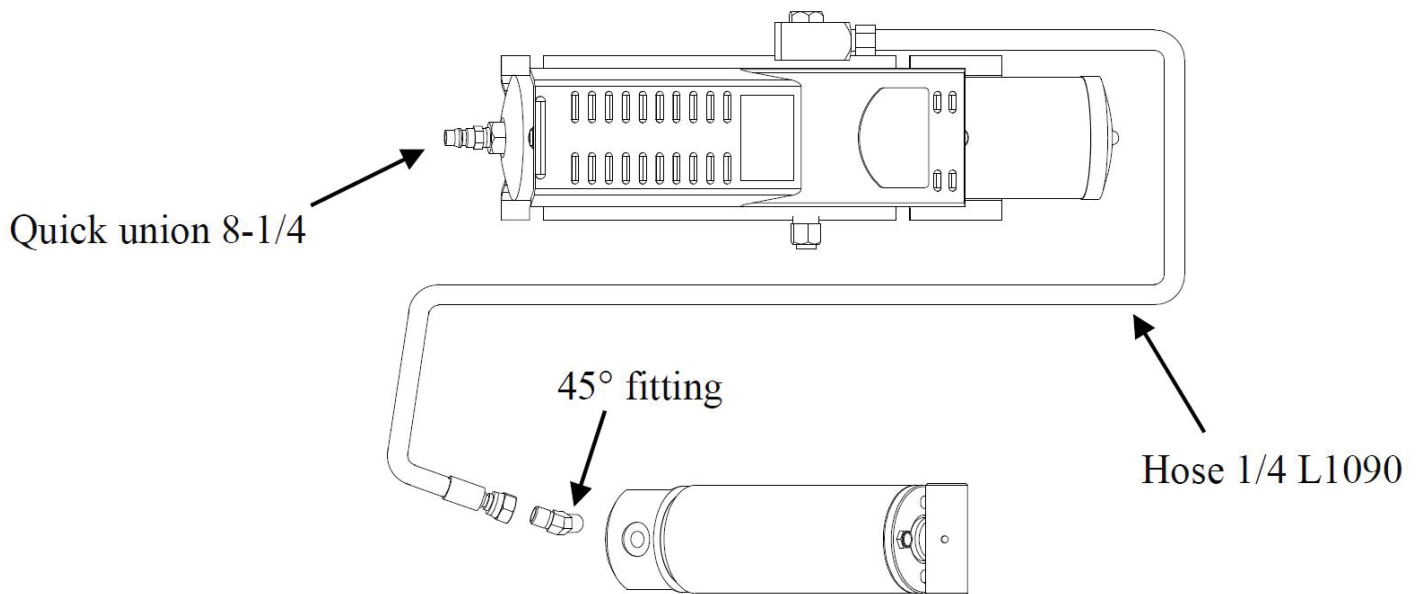

Figure 34 – Hydraulic Line Connection Of Jacking Beam

- Without a vehicle loaded, depress the pedal of the pump to raise the jack at full stroke to check for the proper operation.
- Check for the first lock operation by lowering the jack to the first lock position (about 444mm high) and then raising the jack to clear off the lock and in the meantime flipping the lock release handle up off the lock.
- Check for the second lock operation by lowering the jack to the second lock position (about 351mm high) and then raising the jack to clear off the lock and in the meantime flipping the lock release handle up off the lock.

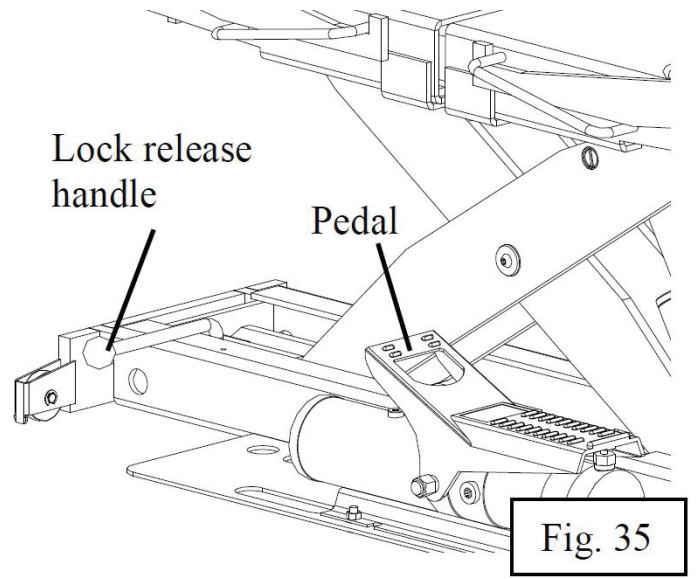

Fig. 35

Operation And Use

Never operate the lift with any person or equipment below.

Never exceed the rated lifting capacity.

Always ensure that all latches are engaged well before any attempt is made to work on or near the vehicle.

Never leave the lift in an elevated position unless the safeties are engaged.

If an anchor bolt becomes loose or any component of the lift is found to be defective, **DO NOT USE THE LIFT** until repairs are made.

8.1 Controls Of Lift

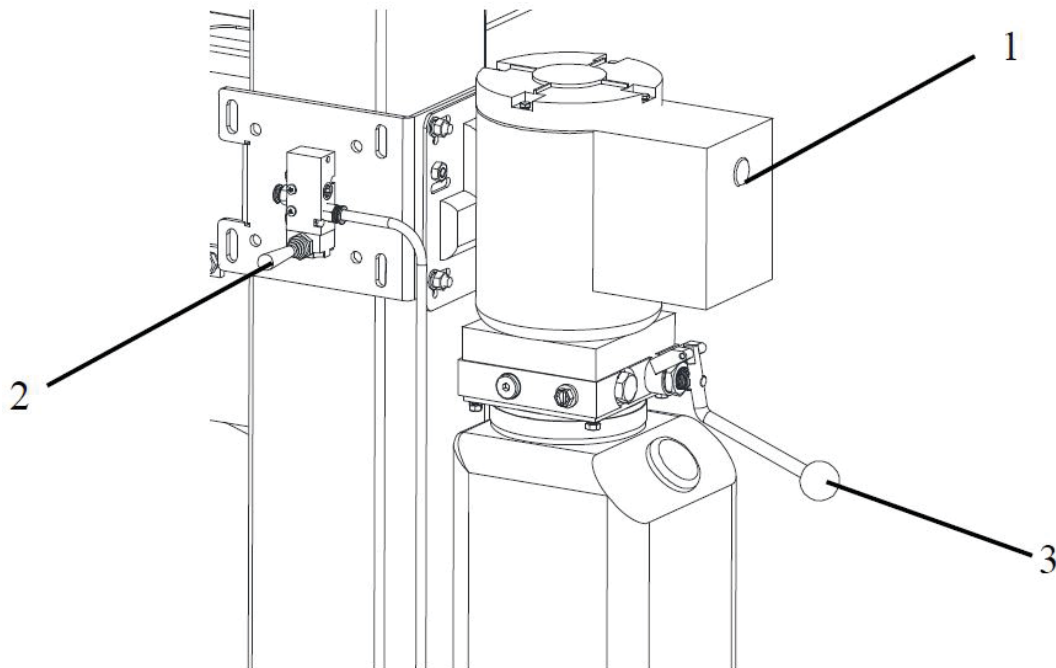

Figure 36 – Controls Of Lift

Controls for operating the lift are:

LIFTING BUTTON (1)

- When pressed, the power unit is running and the lift can be raised to a desired height until the button is released.

AIR CONTROL VALVE (2)

- When pressed, the lock latches will be released so that the lift can be lowered.

LOWERING HANDLE (3)

- When the air control valve is not pressed, press the lowering handle to lower the lift to engage the nearest latch rack.
- When the latches are released by pressing the air control valve, press the lowering handle in the meantime to lower the lift to the desired height under its weight and the load lifted until the handle is released.

Lift operation can be summarized into three steps:

8.1.1 *Lifting*

- Pay attention to overhead clearance;
- The lift must be fully lowered and no one in the service area while the vehicle is driven onto the lift;
- Position the wheels in center of each runway;
- Stop the vehicle when it contacts the front stops or at the desired position;
- Set the parking brake or place the wheel chocks on each side of the rear wheels;
- Make sure the all personnel must be exit before the lift is raised;
- Raise the lift by pushing the lifting button until reaching the desire height.

8.1.2 Standing

- Press the lowering handle to engage the nearest latch position;
- Always ensure that the latch in each column is engaged before any attempt is made to work on or near the vehicle.

8.1.3 Lowering

- Be sure the safety area is free of people and objects;
- Raise the lift high enough by pushing the lifting button to clear off the locks;
- Lower the lift by pressing both the air control valve and the lowering handle;
- Observe the lift and the vehicle to be sure the lift is level while being lowered;
- Lower the lift fully;
- Remove the wheel chocks and check to be sure that the area is clear before removing the vehicle off the lift.

Maintenance



Only trained personnel who knows how the lift works, must be allowed to service the lift.

To service properly the lift, the following has to be carried out:

- use only genuine spare parts as well as equipment suitable for the work required;
- follow the scheduled maintenance and check periods shown in the manual;
- discover the reason for possible failures such as too much noise, overheating, oil blow-by, etc.
- refer to documents supplied by the manufacture or dealer to carry out maintenance.



Before carrying out any maintenance or repair on the lift, disconnect the power supply, padlock the general switch and keep the key in a safe place to prevent unauthorized persons from switching on or operating the lift.

9.1 Ordinary maintenance

The lift has to be properly cleaned at least once a month using self-cleaning clothes.



The use of water or inflammable liquid is strictly forbidden.

Be sure the rod of the hydraulic cylinders is always clean and not damaged since this may result in leakage from seals and, as a consequence, in possible malfunctions.

9.2 Periodic Maintenance

Daily pre-operation	<ul style="list-style-type: none"> • Check hydraulic connections and hoses for leaks • Check air connections and hoses for leaks • Check safety lock audibly and visually while in operation • Check bolts, nuts and screws are tight
Every 1 month	<ul style="list-style-type: none"> • Check all cable connections, pins and bolts to insure proper mounting • Check all anchor bolts and retighten if necessary • Check columns for square-ness and plumb • Check steel cable tension, adjust if necessary • Check all lifting pads, replace if necessary • Lubricate sliders with grease • Lubricate all pivot pins • Check the hydraulic oil, fill or replace if necessary • Check hydraulic systems for proper operation
Every 12 months	<ul style="list-style-type: none"> • Verify that all components and mechanisms are not damaged • Verify the equalizer cables are not worn, change if necessary • Check the electrical system to verify that the motors operate properly (this work must be carried out by skilled electricians) • Empty the oil tank and change the hydraulic oil

Troubleshooting

A list of possible troubles and solutions is given below

Trouble:	Possible Cause:	Solution:
The lift does not work	There is no power	Check Power on to restore if necessary
	The electrical wires are disconnected	Reconnect
	The circuit breaker are blown	Check for correct voltage
Replace		
The lift does not raise	The lift is overloaded	Check the vehicle weight
	The motor direction of rotation is not correct.	Interchange the two phases on the main switch
	The oil in the power unit is not sufficient.	Add some hydraulic oil
	The UP button is faulty.	Check UP button and connection for proper operation. Replace if needed
	The lowering valve does not close.	Check and clean, if dirty or replace if faulty
	The suction tube or pump filter is dirty.	Check and clean if needed.
	Presence of air in the hydraulic system	Bleed the hydraulic system
The lifting capacity is not sufficient	The pump is faulty	Check the pump and replace if needed.
	Oil leakages in hydraulic circuit	Check the circuit for any leakage
The lift does not lower when the lowering lever and the safety release lever are pressed	The lowering valve does not work properly	Check the valve and replace if needed.
	The equalizer cables are not in the same tension.	Readjust the equalizer cables.
The lift does not lower smoothly	Presence of air in the hydraulic system	Bleed the hydraulic system
	Lubrication of sliders is not enough.	Grease
	Sliders are damaged	Replace

Part List

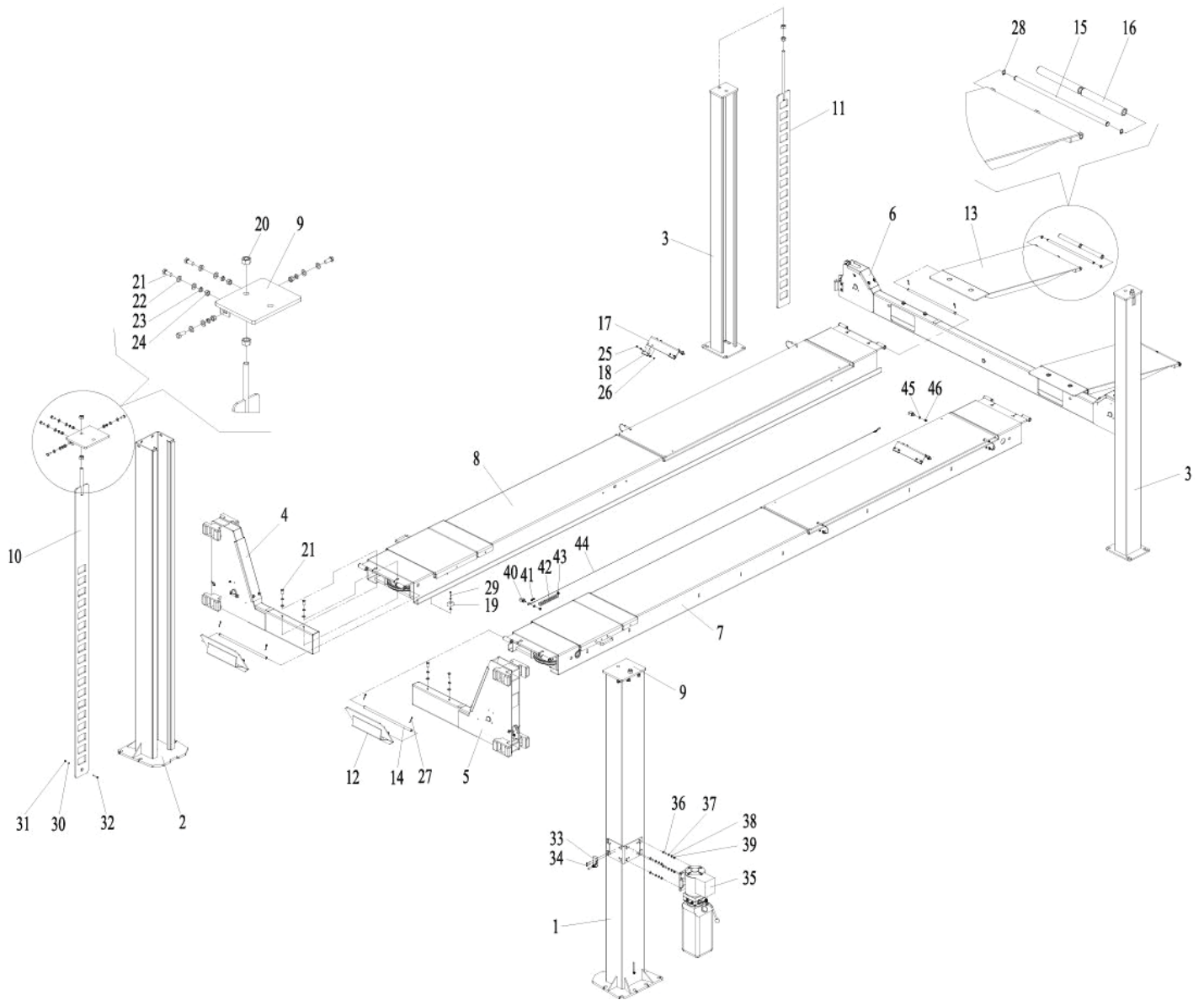

Figure 37 – General Part List

General Part List			
Item	Part Number	Description	Qty
1	Z72D110200A	Power-side column	1
2	Z72D110200B	Front column	1
3	Z72B110100	Rear column	2
4	Z72D220000	Front beam A	1
5	Z72D230000	Front beam B	1

General Part List

Item	Part Number	Description	Qty
6	Z72D210000	Rear beam	1
7	Z72D310000L	Power-side runway	1
8	Z72D320000L	Off-side runway	1
9	Z72D110300	Front top plate	2
10	Z72D111200	Front latch rack	2
11	Z72B111100	Rear latch rack	2
12	Z72D821000	Wheel stop	2
13	Z72D811000	Drive-on ramp	2
14	Z72B810001	Pin	4
15	Z72D810003	Ramp roller pin	2
16	Z72D810002	Ramp roller	4
17	Z72A300101	Angle plate	2
18	Z72A300102	Rubber	8
19	Z72D310013	Retainer	2
20	0203012	Nut M20	8
21	0201061	Screw M12X30	16
22	0205013	Washer D.12	24
23	0208009	Locking washer D.12	16
24	0203023	Nut M12	8
25	0206025	Screw M5X18	16
26	0203031	Nut M5	16
27	0213035	Split pin 4X30	8
28	0212002	Seeger D.16	4
29	0202027	Screw M6X35	2
30	0205006	Washer D.6	4
31	0204003	Self-locking nut M6	4
32	0202028	Screw M6X45	2
33	0306258	Air control valve 1/8	1
34	0206018	Screw M4X30	2
35	0302010	220V/3HP power unit	1
36	0201038	Screw M8X25	4
37	0205008	Washer D.8	4
38	0208006	Locking washer D.8	4
39	0203029	Nut M8	4
40	0215028	Screw M12	2
41	0215085	Clamp	2
42	0306101	Spiral hose L=6000	1
43	0306048	Union D.6-1/4	1
44	0604001	Cable L=5400	1
45	0205013	Washer D.12	2
46	0203023	Nut M12	2

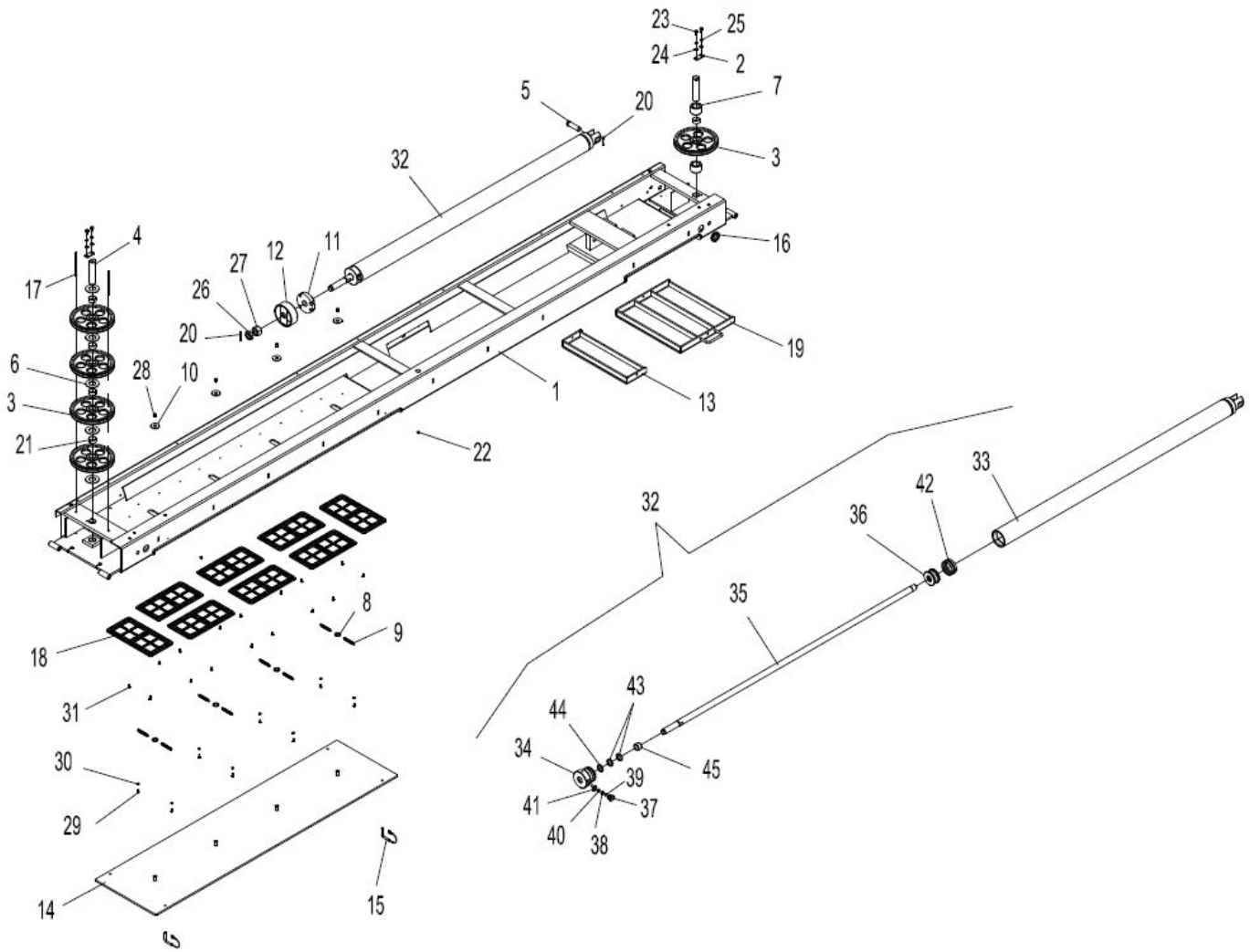

Figure 38 – Power-Side Runway Assembly

Power-Side Runway Assembly			
Item	Part Number	Description	Qty
1	Z72D311000L	Runway weldment	1
2	Z72B220005	Fastening plate B	2
3	Z72B210002	Cable pulley	5
4	Z72B310001	Pulley shaft	2
5	Z72B310002	Cylinder pin	1
6	Z72B310003	Nylon washer	5
7	Z72D310004	Nylon spacer	2
8	Z72D310007	Spring holder	4
9	Z72D310009	Spring	8
10	Z72D310010	Nylon washer	4
11	Z72B310100	Cable holder	1

Power-Side Runway Assembly

Item	Part Number	Description	Qty
12	Z72B310200	Cable retainer	1
13	Z72D310300	Recess spacer	1
14	Z72D310400	Rear slipping plate	1
15	Z72D841000	Plate stop pin	2
16	Z72B310012	Hose relief	1
17	Z72B310014	Anti-derailment pin	4
18	J63A332000	Nylon bearing unit	8
19	Z72D310200	Recess cover	1
20	0213113	Split pin 5X50	2
21	0210052	Bush 4020/SF-1	5
22	0206031	Screw M6X10	2
23	0201062	Screw M10X20	4
24	0205011	Washer D.10	4
25	0208007	Locking washer D.10	4
26	0204019	Jam nut M33X2	1
27	0203038	Nut M33X2	1
28	0207036	Screw M8X20	4
29	0201013	Screw M6X16	8
30	0203035	Nut M6	8
31	0206032	Screw M6X16	16
32	Z72BY90000	Cylinder unit	1
33	Z72BY90100	Cylinder liner	1
34	Z72BY90001	Guiding cover	1
35	Z72BY90002	Cylinder shaft	1
36	Z72BY90003	Piston	1
37	Z72BY90008	Restrictor body	1
38	Z11AY63806	Seager ring	1
39	Z11AY63807	Flow restrictor	1
40	021105	Seeger D. 19	1
41	0313076	Washer 3/4	1
42	0312018	Gasket 90X70X22.4 *	1
43	0310031	Seal 36X46X8 *	2
44	0311016	Scraper 36X44X5/6.5 *	1
45	0305006	Guiding ring 36X25X2.5 *	1
*	Z72BY90000S	Seal kit	1

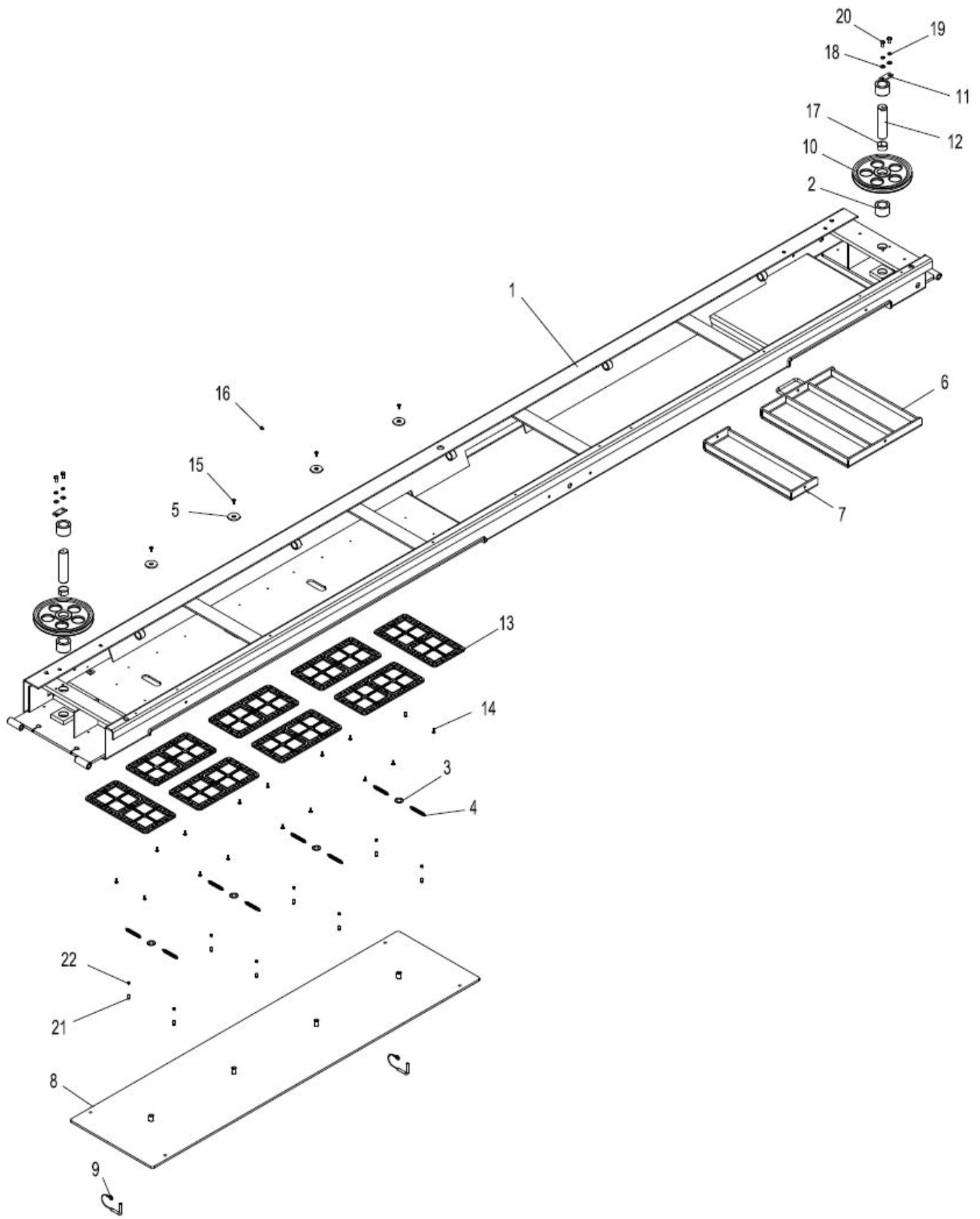

Figure 39 – Off-Side Runway Assembly

Off-Side Runway Assembly

Item	Part Number	Description	Qty
1	Z72D321000L	Runway weldment	1
2	Z72D310004	Nylon spacer	2
3	Z72D310007	Spring holder	4
4	Z72D310009	Spring	8
5	Z72D310010	Nylon washer	4
6	Z72D310200	Recess cover	1
7	Z72D310300	Recess spacer	1
8	Z72D310400	Rear slipping plate	1
9	Z72D841000	Plate stop pin	2
10	Z72B210002	Cable pulley	2
11	Z72B220005	Fastening plate B	2
12	Z72B310001	Pulley shaft	2
13	J63A332000	Nylon bearing unit	8
14	0206032	Screw M6X16	16
15	0207036	Screw M8X20	4
16	0206031	Screw M6X10	2
17	0210052	Bush 4020/SF-1	2
18	0205011	Washer D.10	4
19	0208007	Locking washer D.10	4
20	0201062	Screw M10X20	4
21	0201013	Screw M6X16	8
22	0203035	Nut M6	8

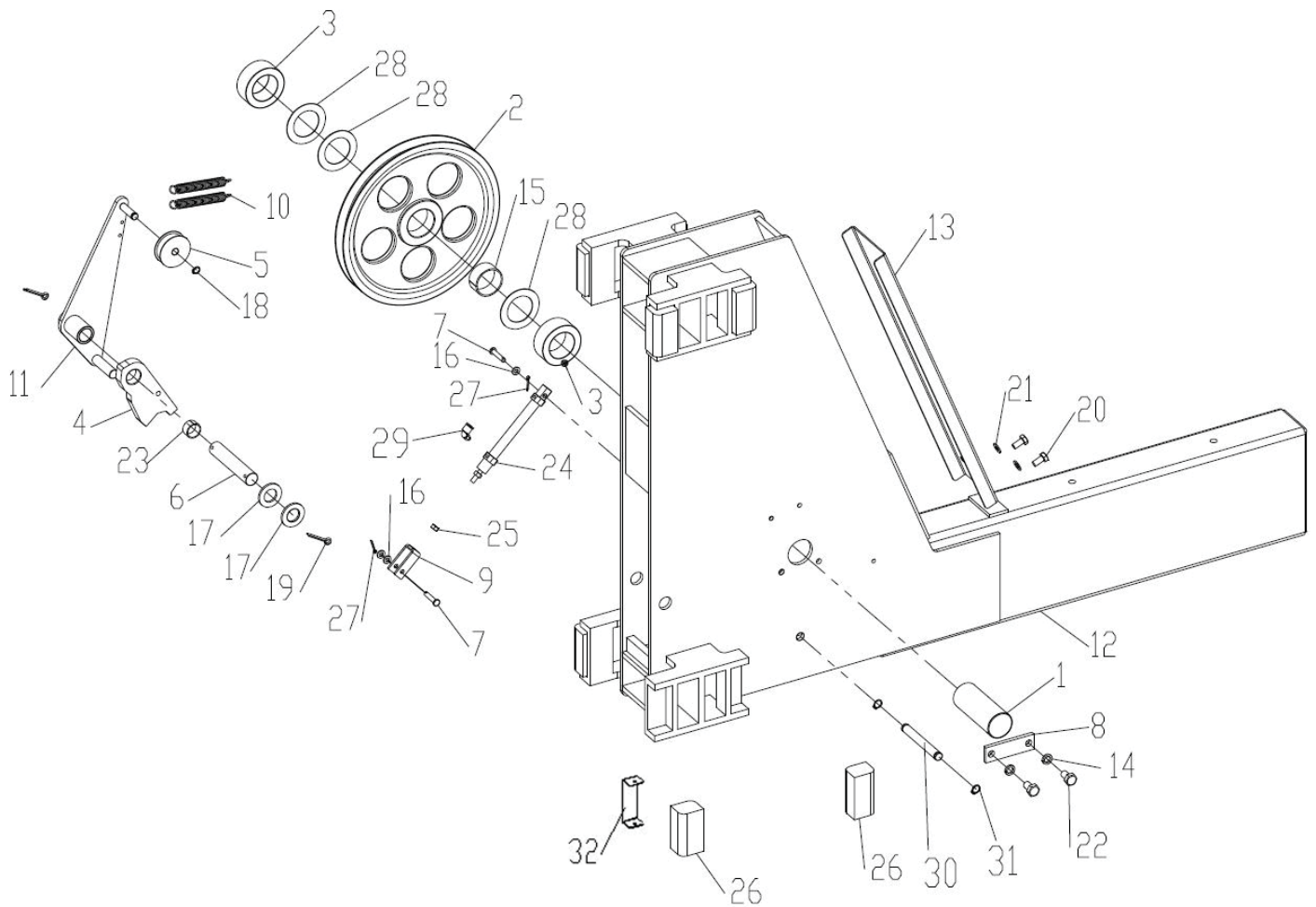

Figure 40 – Front Beam A Assembly

Front Beam A Assembly			
Item	Part Number	Description	Qty
1	Z72B210001	Pulley shaft	1
2	Z72B210002	Cable pulley	1
3	Z72B210003	Nylon spacer	2
4	Z72B210004	Safety latch	1
5	Z72B210005	Nylon roller	1
6	Z72B210006	Latch shaft	1
7	Z72B210007	Pin	2
8	Z72B210008	Fastening plate A	1
9	Z72B210009	Cylinder joint	1
10	Z71P211811	Spring	2
11	Z72D222000	Cable slack lever	1
12	Z72D221000	Beam A weldment	1

Front Beam A Assembly

Item	Part Number	Description	Qty
13	Z72D220013	Pulley cover	1
14	0208007	Locking washer D.10	2
15	0210052	Bush 4020/SF-1	1
16	0205006	Washer D.6	3
17	0205022	Washer D.20	2
18	0212013	Seeger D. 10	1
19	0213035	Split pin 4X30	2
20	0201026	Screw M8X16	2
21	0205008	Washer D.8	2
22	0201059	Screw M10X16	2
23	0210058	Bush 2012/SF-1	1
24	0306333	Latch release cylinder	1
25	0203035	Nut M6	1
26	XSZ-7-1	Nylon slider	8
27	0213054	Split pin 2X16	2
28	Z72A310010	Steel shim	3
29	0306275	90° quick union 6-M5	1
30	Z72B210013	Shaft	1
31	0212001	Seeger	2
32	Z72D220012	Shims	16

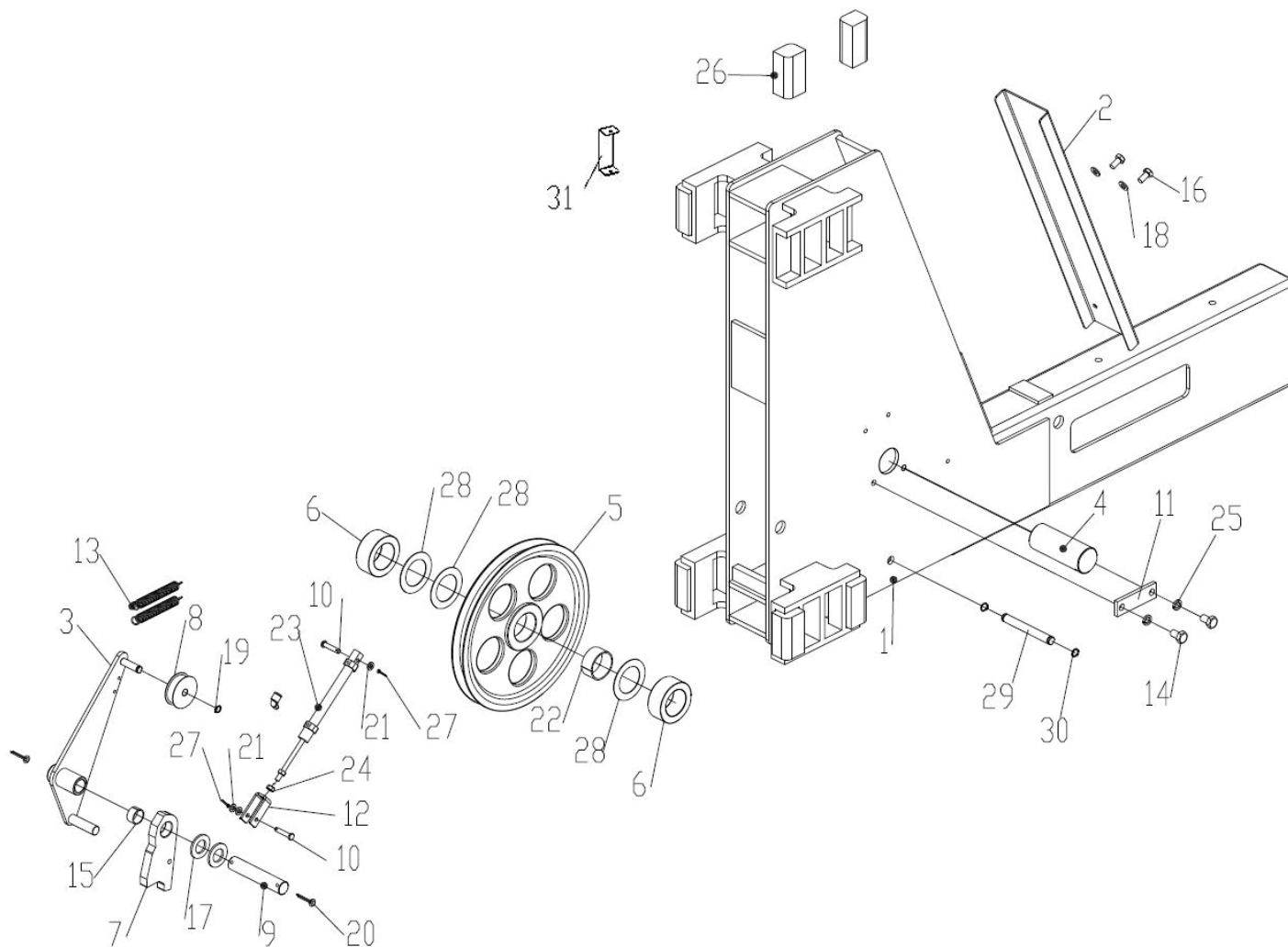

Figure 41 – Front Beam B Assembly

Front Beam B Assembly			
Item	Part Number	Description	Qty
1	Z72D231000	Beam B weldment	1
2	Z72D220013	Pulley cover	1
3	Z72D222000	Cable slack lever	1
4	Z72B210001	Pulley shaft	1
5	Z72B210002	Cable pulley	1
6	Z72B210003	Nylon spacer	2
7	Z72B210004	Safety latch	1
8	Z72B210005	Nylon roller	1
9	Z72B210006	Latch shaft	1
10	Z72B210007	Pin	2
11	Z72B210008	Fastening plate A	1

Front Beam B Assembly

Item	Part Number	Description	Qty
12	Z72B210009	Cylinder joint	1
13	Z71P211811	Spring	2
14	0201059	Screw M10X16	2
15	0210058	Bush 2012/SF-1	1
16	0201026	Screw M8X16	2
17	0205022	Washer D.20	2
18	0205008	Washer D.8	2
19	0212013	Seeger D. 10	1
20	0213035	Split pin 4X30	2
21	0205006	Washer D.6	3
22	0210052	Bush 4020/SF-1	1
23	0306333	Latch release cylinder	1
24	0203035	Nut M6	1
25	0208007	Locking washer D.10	2
26	XSZ-7-1	Nylon slider	8
27	0213054	Split pin 2X16	2
28	Z72A310010	Steel shim	3
29	Z72B210013	Shaft	1
30	0212001	Seeger	2
31	Z72D220012	Shims	16

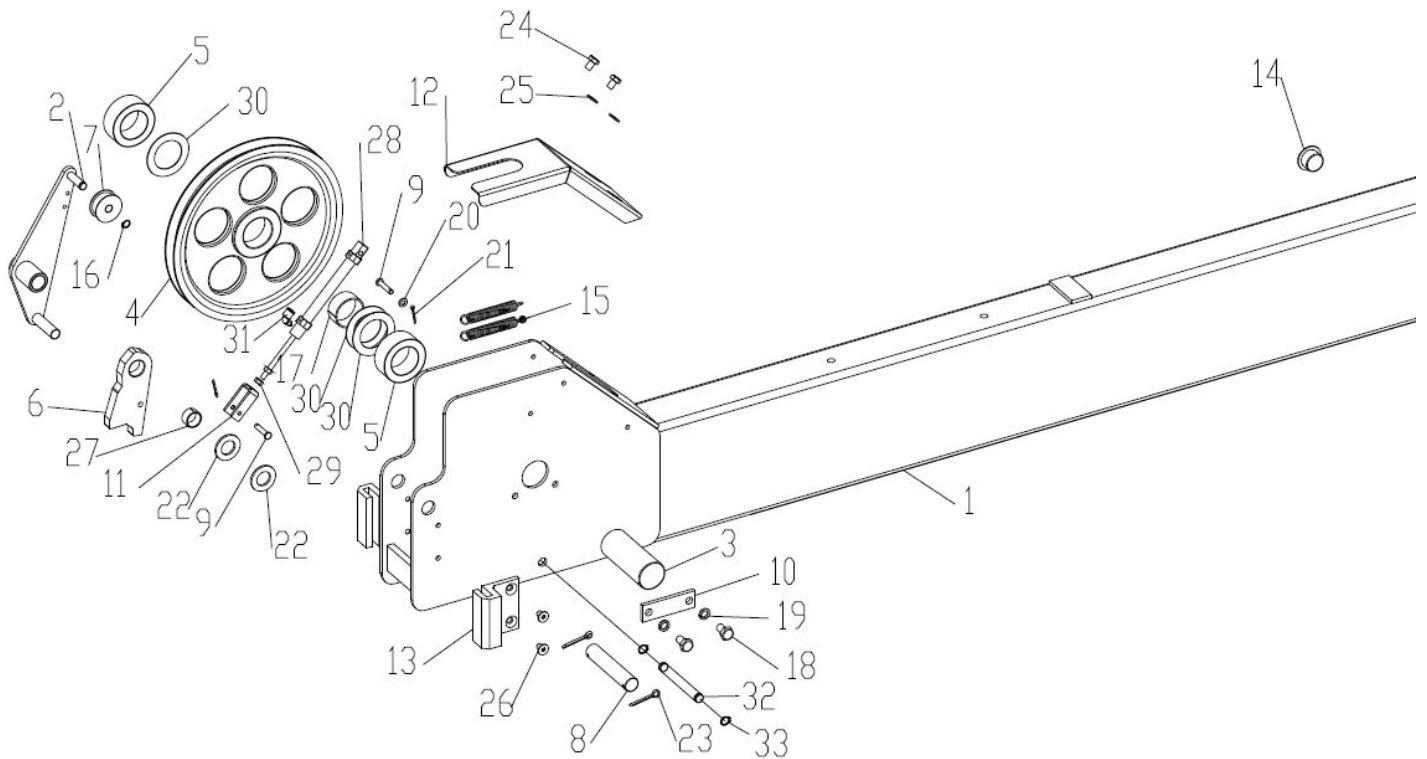

Figure 42 – Rear Beam Assembly

Rear Beam Assembly			
Item	Part Number	Description	Qty
1	Z72D211000	Rear beam weldment	1
2	Z72B212000	Cable slack lever	2
3	Z72B210001	Pulley shaft	2
4	Z72B210002	Cable pulley	2
5	Z72B210003	Nylon spacer	4
6	Z72B210004	Safety latch	2
7	Z72B210005	Nylon roller	2
8	Z72B210006	Latch shaft	2
9	Z72B210007	Pin	4
10	Z72B210008	Fastening plate A	2
11	Z72B210009	Cylinder joint	2
12	Z72B210010	Pulley cover	2
13	Z72B210011	Nylon slider	4
14	Z72B210012	Rubber plug	1
15	Z92A220201	Spring	4

Rear Beam Assembly

Item	Part Number	Description	Qty
16	0212013	Seeger D. 10	2
17	0210052	Bush 4020/SF-1	2
18	0201059	Screw M10X16	4
19	0208007	Locking washer D.10	4
20	0205006	Washer D.6	6
21	0213044	Split pin 2X20	4
22	0205022	Washer D.20	4
23	0213035	Split pin 4X30	4
24	0201022	Screw M8X12	4
25	0205008	Washer D.8	4
26	0207041	Screw M8X12	8
27	0210058	Bush 2012/SF-1	2
28	0306333	Latch release cylinder	2
29	0203035	Nut M6	2
30	Z72A310010	Steel shim	6
31	0306275	90° quick union 6-M5	1
32	Z72B210013	Shaft	2
33	0212001	Seeger	4

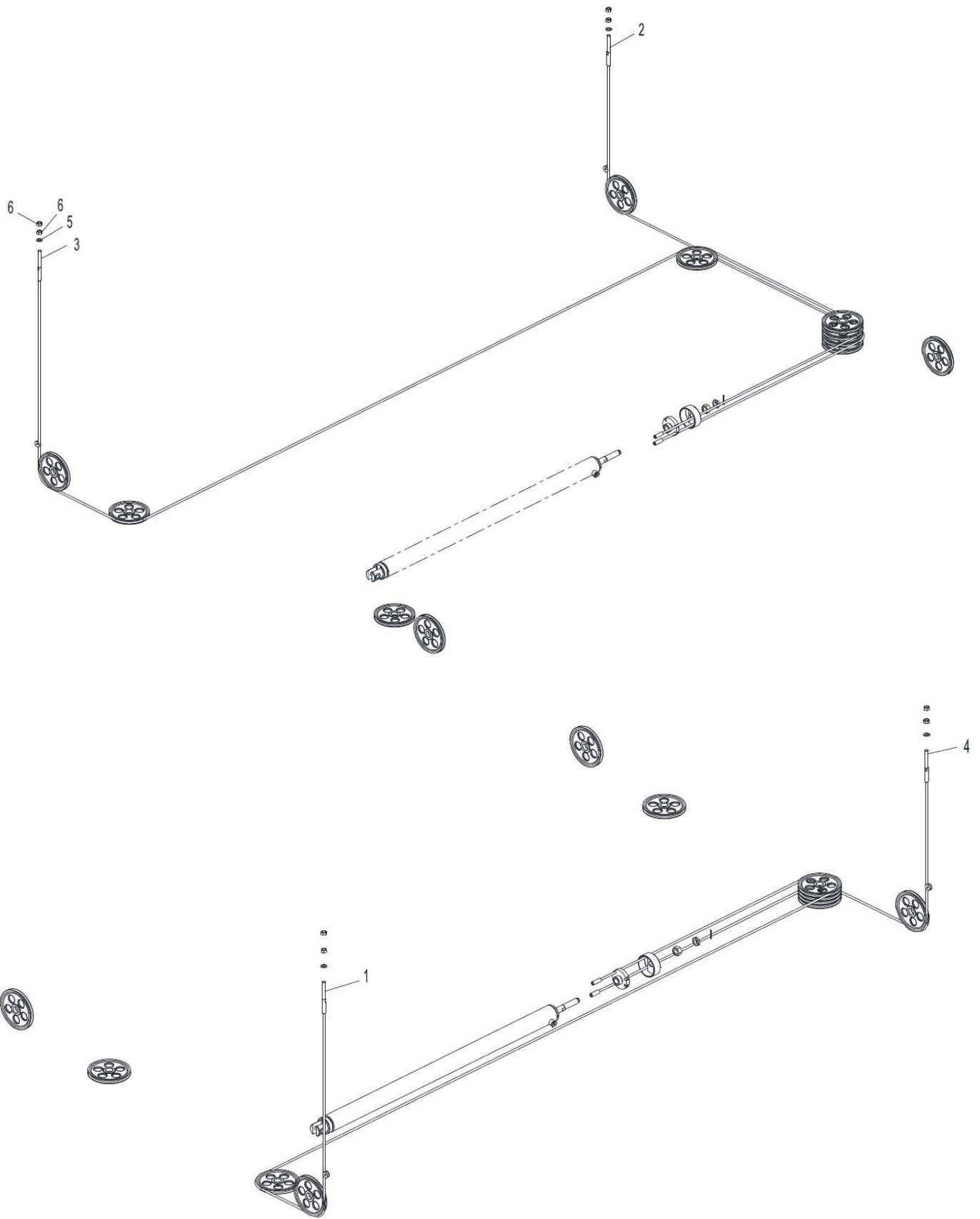

Figure 43 – Steel Cable Assembly

Steel Cable Assembly

Item	Part Number	Description	Qty
1	Z72D850100L	Steel cable A L=10075	1
2	Z72D850200L	Steel cable B L=5535	1
3	Z72D850300L	Steel cable C L=11855	1
4	Z72D850400L	Steel cable D L=4085	1
5	0205022	Washer D.20	4
6	0203012	Nut M20	8

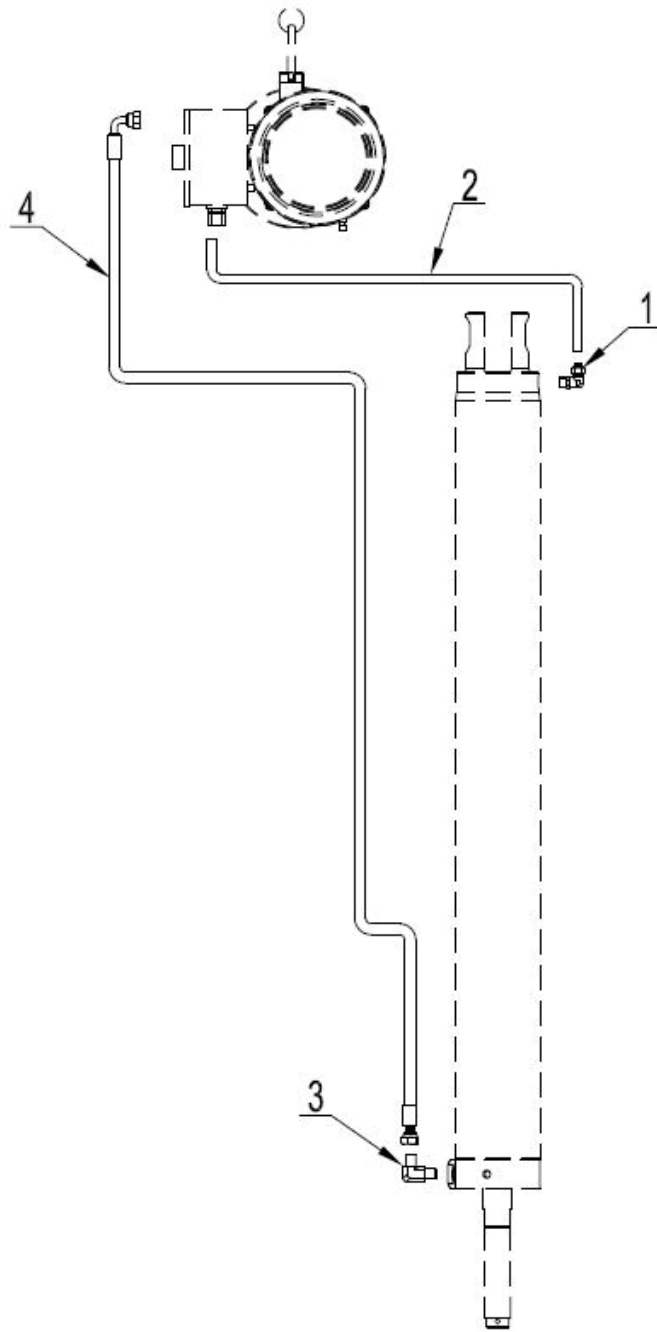

Figure 44 – Hydraulic Line

Hydraulic Line			
Item	Part Number	Description	Qty
1	0306065	Rotation union 8-1/4	1
2	0306096	Rilsan hose 8X5.5 L=2600	1
3	0303002	90° fitting 1/4	1
4	ZW4500	Hydraulic hose 5/16 L=4500	1

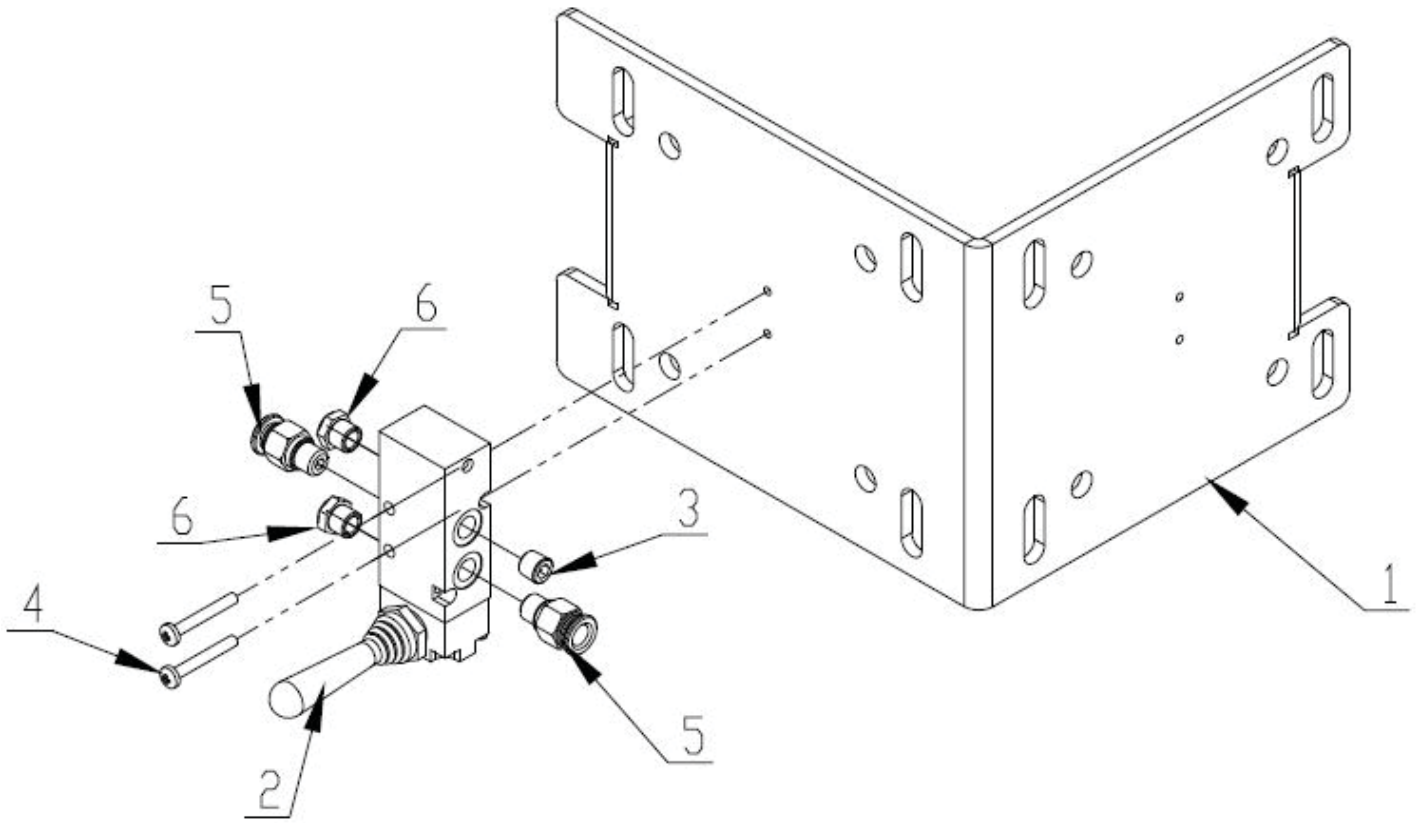

Figure 45 – Latch Release Valve Assembly

Latch Release Valve Assembly			
Item	Part Number	Description	Qty
1	Z72B110207	Motor bracket	1
2	0306258	Air control valve	1
3	0305014	Plug 1/8	1
4	0206018	Screw M4X30	2
5	0306045	Quick union 8-1/8	2
6	0306087	Silencer 1/8	2

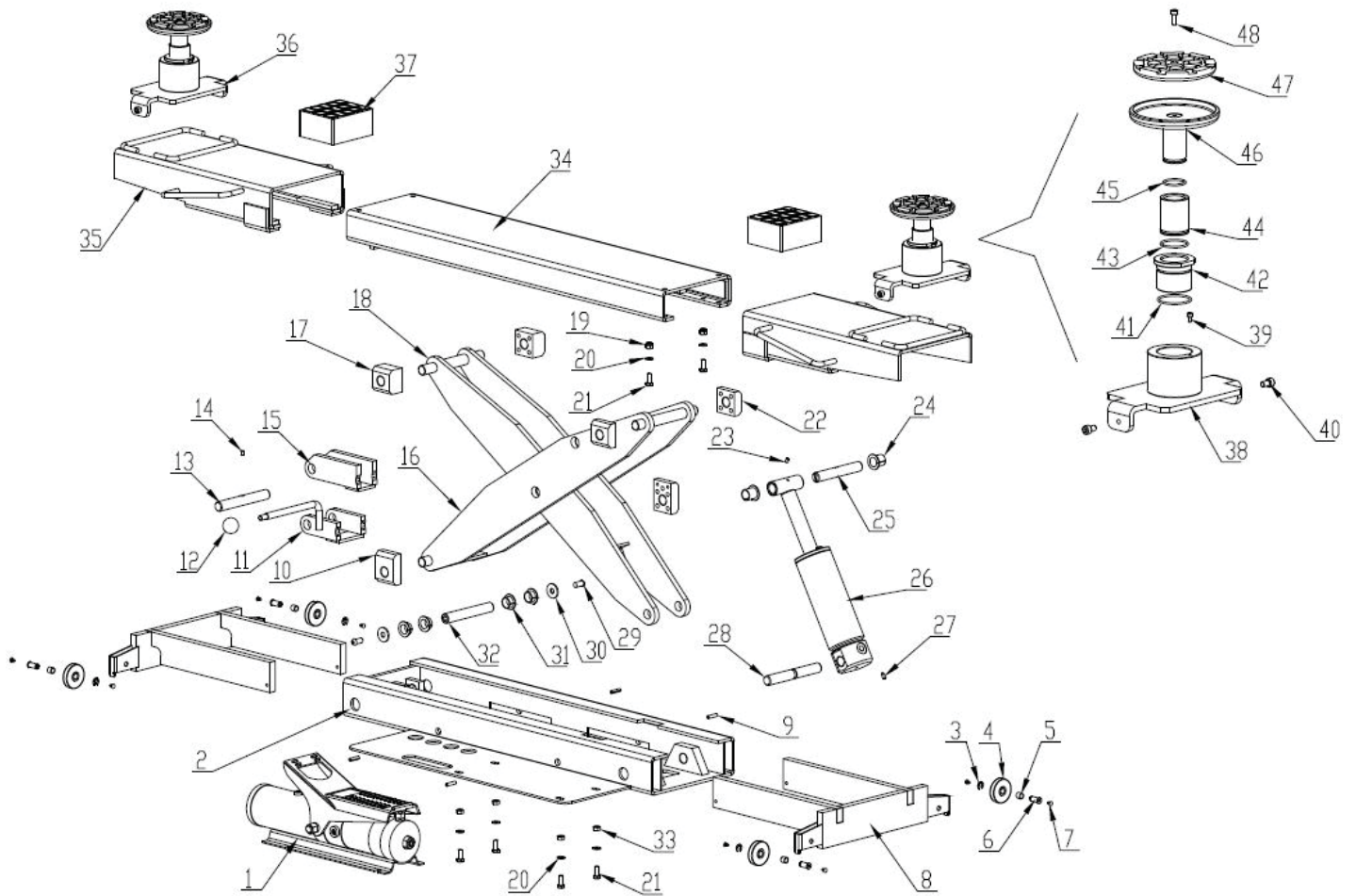

Figure 46 – Rolling Jack Assembly - Optional

Rolling Jack Assembly - Optional			
Item	Part Number	Description	Qty
1	0301030	Air pedal pump	1
2	J07B110000	Jack base	1
3	0211015	Seeger D.8	4
4	J07B100100	Wheel	4
5	0511172	Nylon bush 1010	4
6	J07B100001	Wheel shaft	4
7	0511173	Nylon pin	8
8	J07B120000	Base extension	2
9	0213109	Elastic pin 6X25	4
10	J07B000003	Nylon lower slider	2
11	J07B000200	Safety lock 2	1
12	0215017	Knob M10X33	1

Rolling Jack Assembly - Optional			
Item	Part Number	Description	Qty
13	J07B000005	Shaft	1
14	0209010	Screw M6X10	1
15	J07B000100	Safety lock 1	1
16	J07B200000	Outer scissor arm	1
17	J07B000001	Nylon upper slider 1	2
18	J07B300000	Inner scissor arm	1
19	0204004	Self-locking nut M8	2
20	0205008	Washer D.8	6
21	0201043	Screw M8X20	6
22	J07B000002	Nylon upper slider 2	2
23	0209030	Screw M6X8	1
24	0210089	Bush SF-1/2024F	2
25	J07B000007	Cylinder upper shaft	1
26	J07BY63000	Jack hydraulic cylinder	1
27	0209002	Screw M6X10	3
28	J07B000006	Cylinder lower shaft	1
29	0206069	Screw M10X20	2
30	J07B000008	Washer	2
31	0210086	Bush SF-1/2012F	4
32	J07B000004	Middle shaft	1
33	0203008	Nut M8	4
34	J07B400000	Jack table	1
35	J07B500000	Table extension	2
36	J07B600000	Lifting adaptor	2
37	0606033	Rubber pad 115X100X55	2
38	J07B600100	Adaptor base	2
39	0202020	Screw M5X8	2
40	0202043	Screw M8X12	4
41	0309091	O-ring 45X2.65	2
42	Z23A313002	Outer thread bush	2
43	0212034	Seeger D.42	2
44	Z23A313001	Inner thread bush	2
45	0212035	Seeger D.32	2
46	Z23A313100	Pad tray	2
47	Z23A313202	Round rubber pad	2
48	0202032	Screw M6X16	2

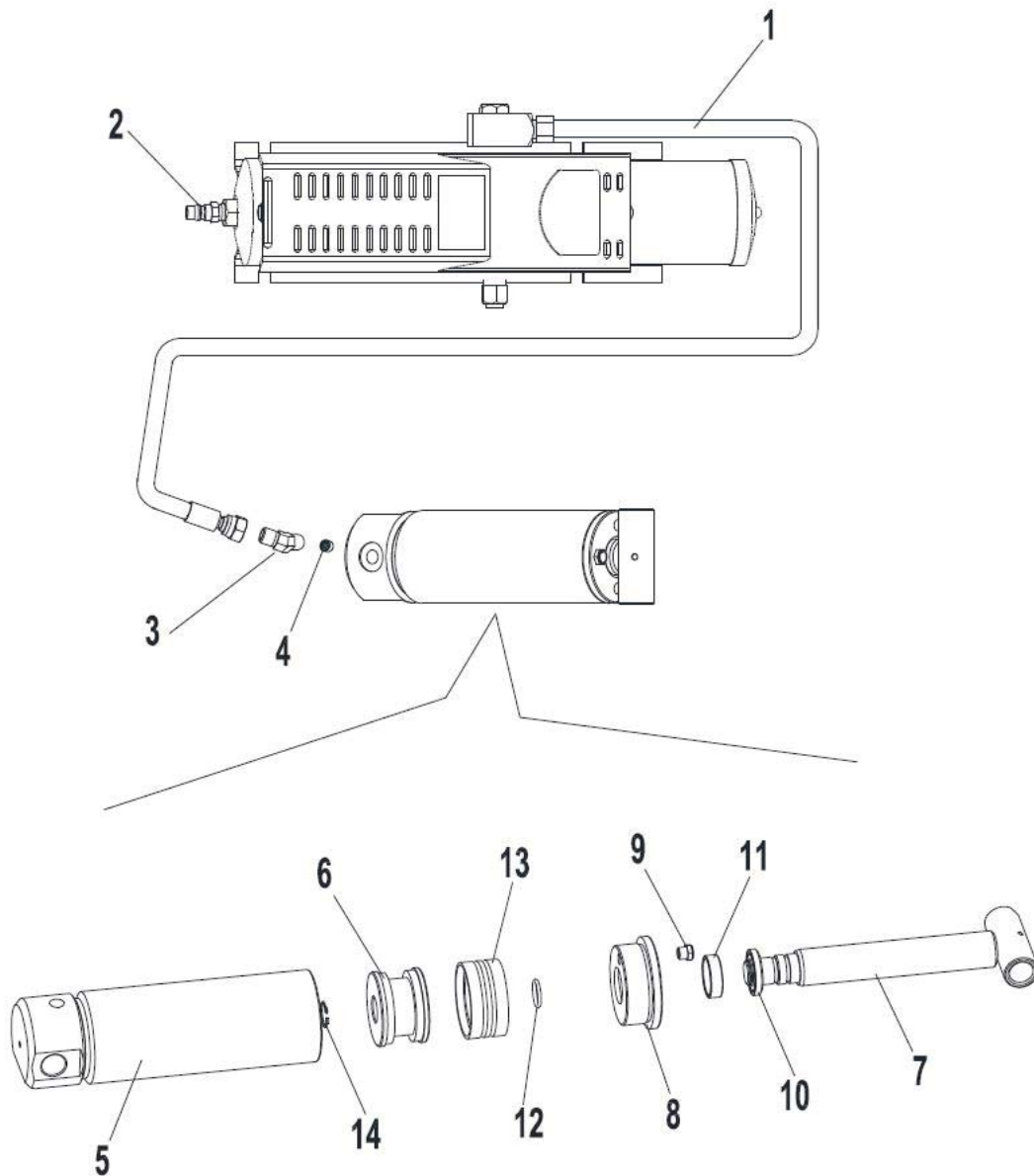

Figure 47 – Jack Hydraulic Cylinder Unit And Line

Jack Hydraulic Cylinder Unit And Line			
Item	Part Number	Description	Qty
1	ZY1090	Hose 1/4 L=1090	1
2	0306112	Quick union 8-1/4	1
3	0303020	45° union	1
4	0307022	Parachute valve 1/4	1
5	J07BY63100	Cylinder liner	1
6	8240TX-63-2	Piston	1
7	J07BY63200	Cylinder shaft	1

Jack Hydraulic Cylinder Unit And Line

Item	Part Number	Description	Qty
8	8240TX-63-3	Cylinder guiding cover	1
9	0306087	Silencer 1/8	1
10	0311005	Scraper 30X38X5/6.5	1
11	0305007	Guiding ring 30X10X2.5	1
12	0309022	O-ring 24X2.4	1
13	0312012	Gasket 63X47X18.4	1
14	0212005	Seeger D.20	1

Warranty



This item is warranted for five (5) years on structural components, two (2) years on hydraulic cylinders, and one (1) year on electric or air / hydraulic power units from invoice date. Wear items are covered by a 90 day warranty.

Our LIMITED warranty policy does **not include a labor** warranty. Our products are sold at such a competitive price that Atlas Automotive Equipment cannot afford to send technicians into the field to repair the Atlas® automotive lifts. We assume that the buyer of our automotive lifts is mechanically inclined or has employees that are mechanically inclined to perform essential repair services and or maintenance. We also have a list of service technicians that can come to your facility/house at the customer's expense.

NOTE: ALL WARRANTY CLAIMS MUST BE PRE-APPROVED BY THE MANUFACTURER TO BE VALID.

The Manufacturer shall repair or replace at their option for this period those parts returned to the factory freight prepaid, which prove after inspection to be defective. This warranty will not apply unless the product is installed, used and maintained in accordance with the Manufacturers installation, operation and maintenance instructions.

This warranty applies to the ORIGINAL purchaser only, and is non-transferable. The warranty covers the products to be free of defects in material and workmanship but, does not cover normal maintenance or adjustments, damage or malfunction caused by: improper handling, installation, abuse, misuse, negligence, carelessness of operation or normal wear and tear. In addition, this warranty does not cover equipment when repairs or alterations have been made or attempted to the Manufacturer's products.

THIS WARRANTY IS EXCLUSIVE AND IS LIEU OF ALL OTHER WARRANTIES EXPRESSED OR IMPLIED INCLUDING ANY IMPLIED WARRANTY OR MERCHANTABILITY OR ANY IMPLIED WARRANTY OF FITNESS FROM A PARTICULAR PURPOSE, AND ALL SUCH IMPLIED WARRANTIES ARE EXPRESSLY EXCLUDED.

THE REMEDIES DESCRIBED ARE EXCLUSIVE AND IN NO EVENT SHALL THE MANUFACTURER, NOR ANY SALES AGENT OR OTHER COMPANY AFFILIATED WITH IT OR THEM, BE LIABLE FOR SPECIAL CONSEQUENTIAL OR INCIDENTAL DAMAGES FOR THE BREACH OF OR DELAY IN PERFORMANCE OF THIS WARRANTY. THIS INCLUDES, BUT IS NOT LIMITED TO, LOSS OF PROFIT, RENTAL OR SUBSTITUTE EQUIPMENT OR OTHER COMMERCIAL LOSS.

The warranty shall be governed under the laws of Indiana, and shall be subject to the exclusive jurisdiction of the Court in the State of Indiana in the county of Marion.

PRICES: Prices and specifications are subject to change without notice. All orders will be invoiced at prices prevailing at time of shipment. Prices do not include any local, state or federal taxes.

RETURNS: Products may not be returned without prior written approval from the Manufacturer.

DUE TO THE COMPETITIVENESS OF THE SELLING PRICE OF THESE LIFTS, THIS WARRANTY POLICY WILL BE STRICTLY ADMINISTERED AND ADHERED TO.