

INSTALLATION & OPERATION MANUAL





Atlas Platinum 501

Wireless 8 Camera Alignment Machine



Atlas Automotive Equipment
www.atlasautoequipment.com
(866) 898-2604

SYMBOLS USED IN THE MANUAL

	SYMBOLS
	FORBIDDEN!
	Mandatory! Operations or jobs to be performed compulsorily
	Hazard! Be especially careful

CONTENTS

0	CAUTION	3
0.1	Preliminary Safety Information	3
1	INTENDED USE	4
2	OPERATOR TRAINING	4
2.1	General Preventive Measures	4
3	MACHINE COMPOSITION	5
3.1	Models ARS680WS, ARS680WD and ARS660WD Composition	5
3.2	Safety Devices	6
3.3	Measurement Range and Accuracy	6
3.4	Overall Dimensions	6
3.5	Managing PC	6
3.6	Detectors	7
3.6.1	<i>Front Detectors</i>	8
3.6.2	<i>Rear Detectors ARS680WS-WD</i>	8
3.6.3	<i>Rear Detectors ARS660WD</i>	8
3.6.4	<i>Detector Keypads</i>	9
3.7	Connection cables	9
3.8	Clamps	10
3.8.1	<i>Clamps STDA33</i>	10
3.8.2	<i>Clamps STDA34</i>	10
3.8.3	<i>Clamps STDA35</i>	11
3.8.4	<i>Clamps STDA46</i>	11
3.9	Rotating Plates	12
3.9.1	<i>Rotating Plates S110A7</i>	12
3.9.2	<i>Electronic Rotating Plates Connected to Detectors with STDS43 Via Radio Transmission (for ARS680WS models only)</i>	12
4	SWITCHING THE MACHINE ON AND OFF	13
4.1	Switching the Machine On	13
4.2	Switching the Machine Off	13
5	DETECTORS AUTOMATIC SWITCHING OFF	15
6	FLAT BATTERY INDICATION	15
7	PROGRAMME CONFIGURATION	16
7.1	DATABASE Groups Configuration	17
8	VEHICLE DIAGNOSIS AND ADJUSTMENT	19
8.1	Introduction Page	19
8.2	Vehicle Make and Model Selection	19
8.3	Selected Vehicle Technical Specification Displaying	22
8.4	Preliminary Operations	23
8.4.1	<i>Vehicle Check Preliminary Operations</i>	23
8.4.2	<i>Run-Out Preparation</i>	23
8.5	Run-Out	24
8.5.1	<i>Run-Out with Raised Wheels</i>	24
8.5.2	<i>Thrust Run-Out with Automatic Acquisition</i>	27
8.5.1	<i>Inclinometer-controlled Thrust Run-Out</i>	29
8.6	Measurement Preliminary Operations	32
8.7	Detectors Alignment and Levelling	33
8.8	Steering Procedure	34
8.9	Vehicle Diagnosis	35

8.10	Adjustment Preliminary Operations	36
8.11	Rear Axle Adjustment	36
8.12	Front Axle Adjustment	37
8.13	Additional Functions Menu	38
8.14	Printout of Measurements taken	39
9	DATABASE CUSTOMISATION	42
9.1	New Group Entry.....	42
9.2	New Group Deletion.....	43
9.3	New Vehicle Entry	44
9.4	Customised Vehicle Deletion	47
10	PROGRAMME AND DATABASE PROTECTION SMART CARD.....	48
10.1	DATABASE Management	48
11	DETECTORS' ERRORS	50
11.1	Data Reception/Transmission Error between Detectors and Cabin.....	50
11.2	Angle Measurement Horizontal Error	50
12	TROUBLES.....	51
13	MAINTENANCE.....	51
14	STORAGE AND SCRAPPING	52
15	MACHINE IDENTIFICATION DATA	52



Bluetooth brands are property of their owners, and are used by Atlas under license.

0 CAUTION

Any damage caused by failure to follow the instructions in this manual or improper machine use shall relieve Atlas of all liability.

0.1 Preliminary Safety Information



Before starting the machine:

- Read the instructions and the entire manual before using or working on the wheel aligner. This manual represents an integral part of the product and is intended to inform the user on how to use the ARS660WD, ARS680WD and ARS680WS wheel aligner. Keep the manual for the entire life of the machine. Keep it in an easy to access place and refer to it every time the need arises. All machine operators must be able to read the manual.
- Make sure the power supply is in conformity with the specifications shown on the plate. Voltage and frequency data plate is positioned on machine back side. Please, read plate data. NEVER connect aligner to a voltage or frequency other than the specified ones.
- Duly arrange wheel aligner power cable. This product features a 3-wire plug with built-in grounding. It can be plugged into a socket with built-in grounding, only. Should a grounded socket not be available for machine connection, contact an electrician. Do not tamper with or misuse plug.

Upon machine switching off:

- Do not switch off the built-in PC by unplugging it or by turning PC switch to off, but follow the procedure set forth in par.4.2 on page 13. PC wrong switching off could lead to HARD-DISK files "corruption".
- The switching off procedure set forth in par. 4.2 on page 13 does not affect detector recharge cables, which continue being powered.

In emergency conditions and before performing any maintenance:

- Insulate the machine against any power source using the special master switch, and remove plug from power socket.
- Do not try to service this unit arbitrarily, as the opening or removal of machine doors could expose user to hazardous voltage. Maintenance operations shall be carried out by authorised service personnel, only.

Work environment and machine cleaning:

- The work environment must be kept clean and dry, and must not be exposed to atmospheric agents. It must also be well lit.
- Do not clean the machine using jets of water and compressed air. To clean plastic panels or surfaces use a moist cloth (avoid using liquids containing solvents).

Atlas shall be entitled to make any changes to the models described in this manual at any time for reasons of a technical and commercial nature.

1 INTENDED USE

ARS660WD, ARS680WD and ARS680WS systems are machines for the detection of all vehicle special angles.

Angles are detected by four detectors with microprocessor technology and infrared measurement system, and data transmission (without any cable connection between detectors).

In ARS680WS models, the data of front cabin detectors are transmitted VIA RADIO through modules  **Bluetooth**.

Vehicle max. allowed wheelbase length for data transmission and angle measurement is 4.5m.

Machine operational temperature range: 0 to 40°C.

2 OPERATOR TRAINING

The machine must be used by specifically trained and authorised personnel, only. To ensure proper machine use and that measurements can be efficiently taken, operators must be correctly trained and acquire the skills consistent with the instructions provided by the manufacturer. In case of any doubts relating to machine use and maintenance, refer to the instruction manual and then, if such doubts persist, contact an authorised after-sales centre or Atlas technical assistance directly.

2.1 General Preventive Measures



- During operation and maintenance of this machine, always abide by the safety and accident-prevention regulations in force.



- The machine must only be used by adequately trained and authorised persons.



- This machine must only be used for the purpose for which it was expressly intended. Atlas declines all liability for injury or damage to persons animals and things caused by improper machine use.



- Accessories and spare parts must be fitted by persons authorised by Atlas and only original spare parts and accessories must be used.



- The machine must only be operated in places where there is no danger of explosions or fire.



- Removal or changes made to safety devices, or warning signals on the machine can cause serious hazards and represent a violation of European safety regulations.



- Before doing any maintenance jobs on the system, always disconnect the power supply.

In case of doubt, do not interpret, but contact Atlas technical assistance in order to obtain instructions suitable for performing operations in total safety.



- Do not allow unauthorised personnel to come near the wheel aligner during use.

3 MACHINE COMPOSITION

3.1 Models ARS680WS, ARS680WD and ARS660WD Composition

PC KEYBOARD

Machine features a 102-key, PC-type command keyboard. Function keys allow using almost all machine functions. Vehicle general data, customer data, and vehicle database customisation can also be entered via PC keyboard.

MONITOR

All models feature a 19", 16/9, high-definition, colour monitor. Monitor use and maintenance instructions can be found on the manual coming with the monitor itself. Comply with these instructions.

MANAGING PC UPPER COMPARTMENT

For PC characteristics see par. 3.5 page 6

MACHINE MASTER SWITCH

SENSORS

See para. 3.6 on page. 7

CENTRAL PRINTER HOUSING

Results are printed with a inkjet colour printer for A4 size sheets. Printer use and maintenance instructions can be found on the manual coming with the printer itself. Comply with these instructions.

LEADS FOR RECHARGING THE SENSOR BATTERIES

CONNECTION CABLES

See para. 3.7 page 9

MEASUREMENT CABIN

A measurement cabin is used for all measurement operations. This cabin also features the electronic components necessary for the processing and management of the readings made by detectors. Power supply: 220 / 240 Vac single phase 50/60Hz. Max. absorbed power: 500w

ROTATING PLATES

See par. 3.9 page 12

CLAMPS

See par. 0 page 9

STEERING LOCK is a tool used to keep vehicle steering in a fixed position. It is used before the adjustment procedure, as shown by the instructions displayed during programme.

PEDAL DEPRESSOR is a tool used to lock brake pedal during measurement preliminary operations. It has to be used as shown in the instructions displayed during programme.

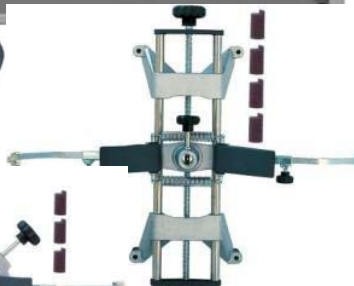
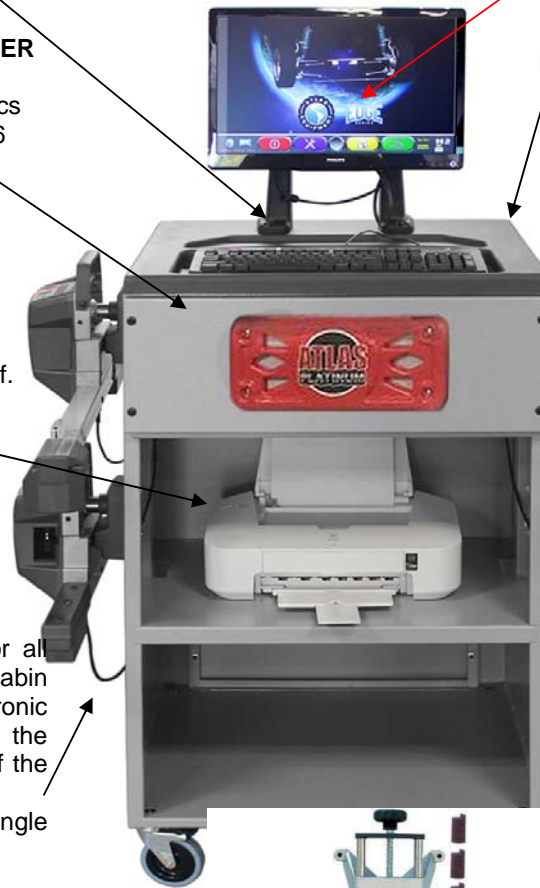

3.2 Safety Devices

Wheel aligner features a safety device (master switch) positioned on the rear of the machine, see chap. 3 on page 5. Master switch cuts off machine power when set to “0”.

3.3 Measurement Range and Accuracy

Axle	Measurement	Accuracy	Measurement Range	Measurement Total Range
Front	Toe	± 2'	± 2°	± 20° x 2
	Partial toe	± 1'	± 1°	± 20°
	Set-back	± 2	± 2°	± 5°
	Camber	± 2'	± 3°	± 10°
	Caster	± 5'	± 10°	± 18°
	Kingpin	± 5'	± 10°	± 18°
Rear	Toe	± 2'	± 2°	± 20° x 2
	Partial toe	± 1'	± 1°	± 20°
	Set-back	± 2'	± 2°	± 5°
	Camber	± 2'	± 3°	± 10°
	Thrust angle	± 2'	± 2°	± 5°

3.4 Overall Dimensions

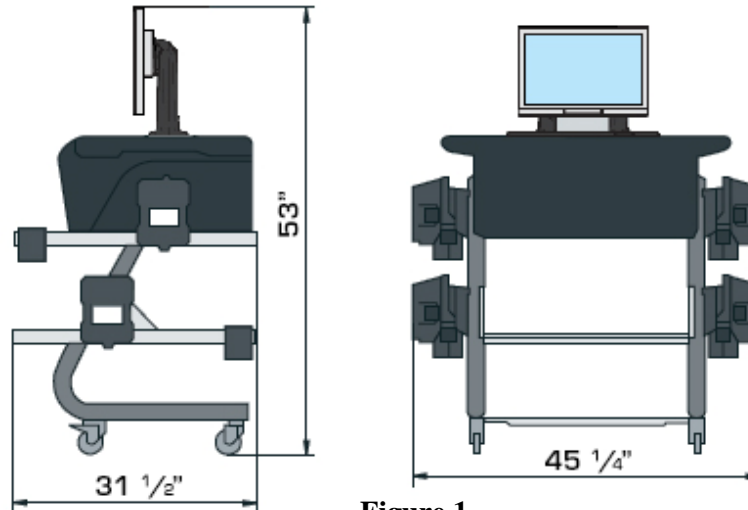

Figure 1

3.5 Managing PC

Software is installed on managing PC (personal computer), positioned inside cabin.

Managing PC features:

- Processor VIA Nano 64bit @ 1.6GHz.
- RAM 1 Gb;
- Smart card reader
- 4 USB; 1 LAN Ethernet 10/100Mb;
- PS2 keyboard and mouse input; Windows XP Embedded Standard 2009™ operating system, in English language
- 1366x768 Pixels HD Ready video output
- Hard Disk ≥ 160 Gb

3.6 Detectors

Detectors assembled on ARS660WD, ARS680WD and ARS680WS do not need any cable or cord connection for angle measurement.

Detecting units consist of infrared data transmitters/receivers and CCD-type transducers with infrared emitter focal point.

All the characteristic angles of vehicle axles are controlled with 8 CCD sensors (6 sensors for the ARS660WD series) and infrared transmission.

Data transmission among infrared detectors is effective also under critical lighting conditions.

For ARS680WS models, data are transmitted from front detectors VIA RADIO through modules  **Bluetooth** located inside front detectors and cabin.

For the transmission of data between the front sensors and the console in wheel aligner ARS680WD and ARS660WD, the connection cable must be fitted in the special connector on the lower of the sensor (see para. 3.6.1 on page 8).

Rear detectors do not communicate directly with cabin: their data are transmitted/received through front detectors, via infrared ray transmission.

Power is supplied by rechargeable 6V long-lasting batteries. For ARS680WS models front detectors and all rear detectors are recharged thanks to the cables for batteries recharge positioned onto cabin.

In the case of ARS660WD and ARS680WD aligners, the front sensors are power conveyed through the connection cables (see para. 3.7 on page 9) because they don't have batteries.

For all detectors with rechargeable batteries, power supply and consumption data are the following:

	REAR DETECTORS	FRONT DETECTORS
Power supply	Lead battery 6V - 3.3Ah (ARS680WS and WD) NiMh battery 6V - 2Ah (ARS660WD)	Lead battery 6V - 3.3Ah
Average operation with fully effective and charged battery	Approx. 12 hours	Approx. 10 hours
Average recharge time	Approx. 10 hours	Approx. 10 hours

3.6.1 Front Detectors

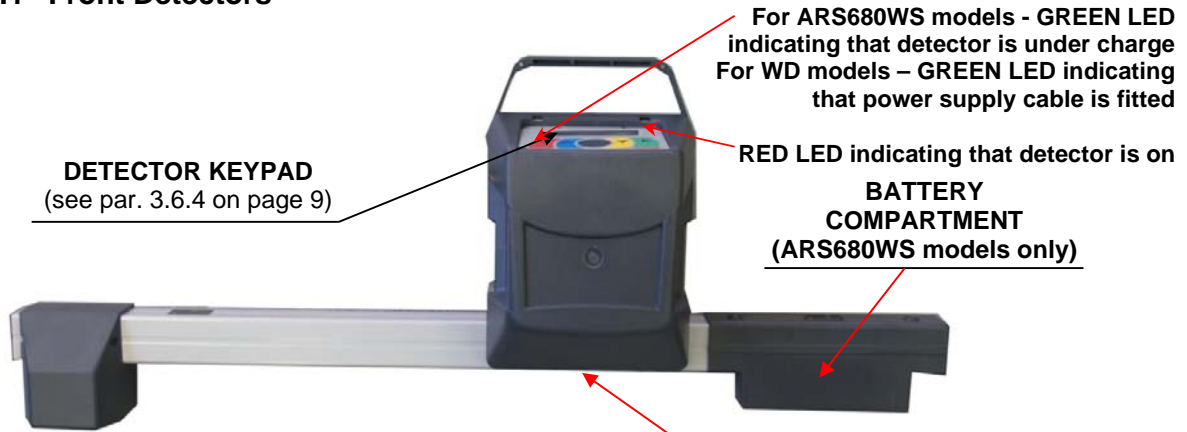

Figure 2

For ARS660WD and ARS680WD models
CONSOLE CONNECTION CABLE CONNECTOR
(see para. 3.7 on page 9)
For ARS680WS models – BATTERY RECHARGE
CABLE CONNECTOR (see para. 3.1 on page 5)

3.6.2 Rear Detectors ARS680WS-WD

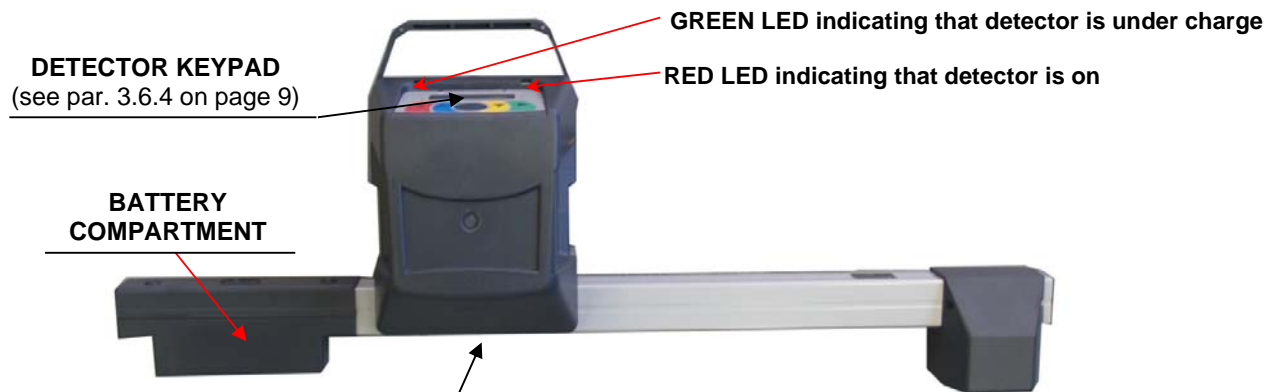

Figure 3

3.6.3 Rear Detectors ARS660WD

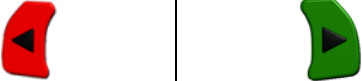

Figure 4

3.6.4 Detector Keypads



Figure 5

KEYS	DESCRIPTION
	Detector switch-on key.
	If pressed at the same time, they allow detector manual switching off.

Legend of Figure 5:

- | | |
|--|--|
| <p>A -</p> <ul style="list-style-type: none"> • Green LED on: <p>B -</p> <ul style="list-style-type: none"> • Red LED steady on: • Red LED flashing (with battery detectors): | <p>For ARS680WS front detectors and for all rear detectors: detector battery is under charge</p> <p>For ARS680WD and ARS660WD front detectors: indicating that power supply cable is fitted</p> <p>detector is on</p> <p>detector is flat (when battery residual charge is lower than or equal to 30%); it will turn off after a few minutes</p> |
|--|--|

3.7 Connection cables

The connection cables are fastened to the front sensors (see Figure 2).

Their job is to permit communication between the front sensors and the console as well as power the sensors themselves.

The rear sensors never communicate directly with the console. Their data are transmitted/received through the front sensors.

Always use the left cable with the left detector and right cable with the right detector. Reversing the cables the communication is not possible. Cables are not interchangeable.

3.8 Clamps

Four types of clamps are available, depending on the different needs.

3.8.1 Clamps STDA33

Clamps STDA33 are of the screw-on self-centering type for 10" to 19" alloy rims, with removable tabs.

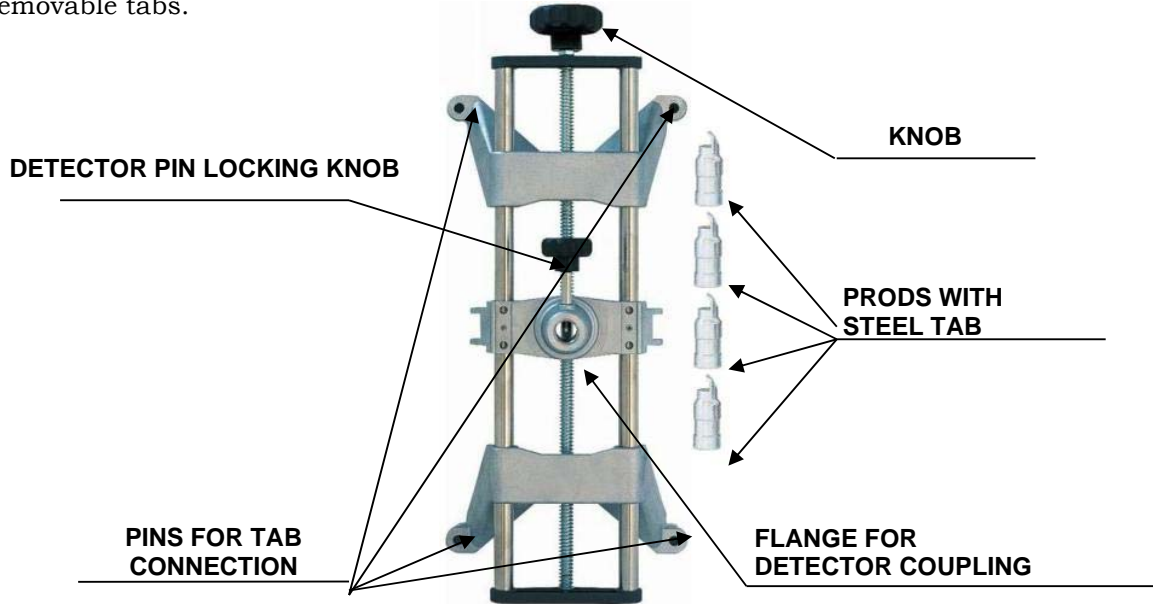

Figure 6

3.8.2 Clamps STDA34

Clamps STDA34 are of the 3-resting point self-centering type for 10" to 19" rims, and feature removable tabs (different types of ABS tabs are available for the different types of alloy rims).

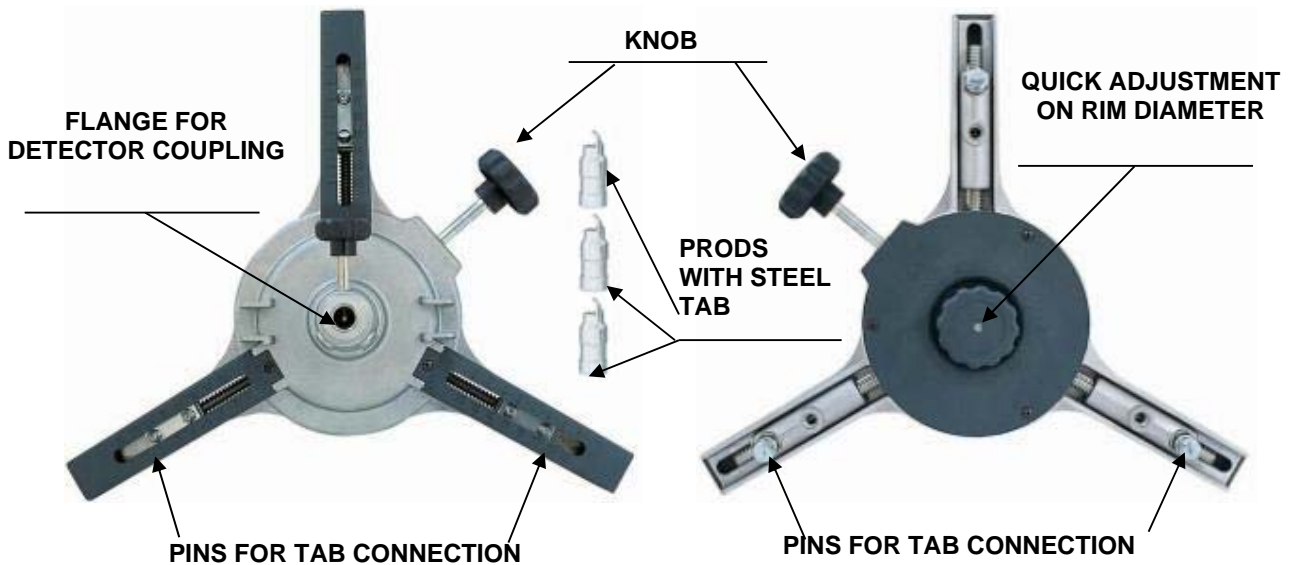

Figure 7

3.8.3 Clamps STDA35

Clamps STDA35 are of the 3-resting point self-centering type for 10" to 20" rims, with manual approach and locking unit on tyre.

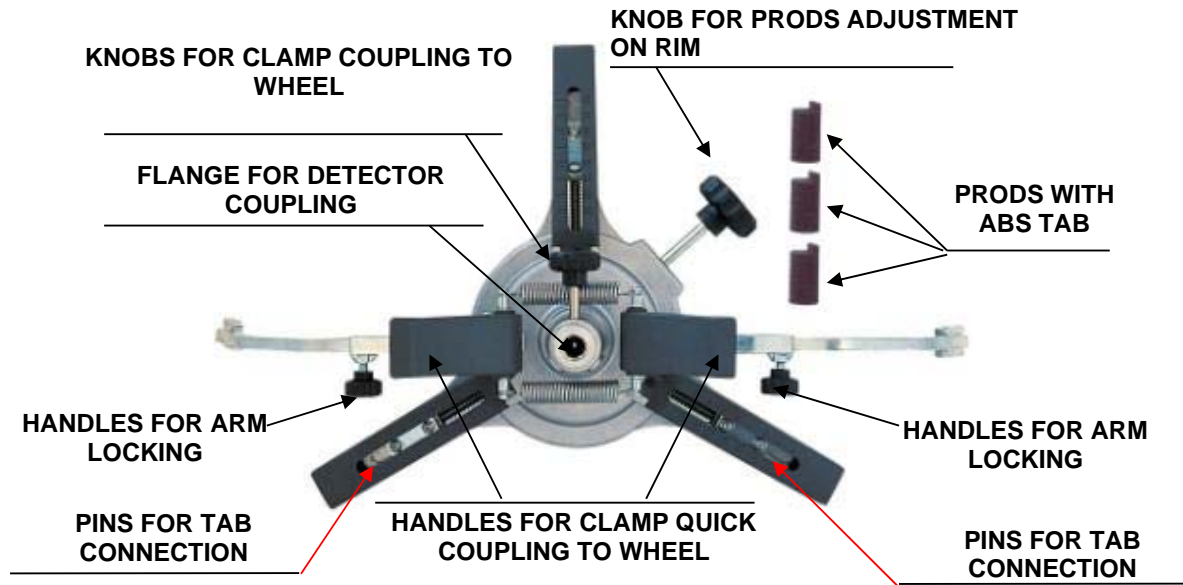

Figure 8

3.8.4 Clamps STDA46

Clamps STDA46 are of the 4-resting point type for 10" to 20" rims, and feature locking units.

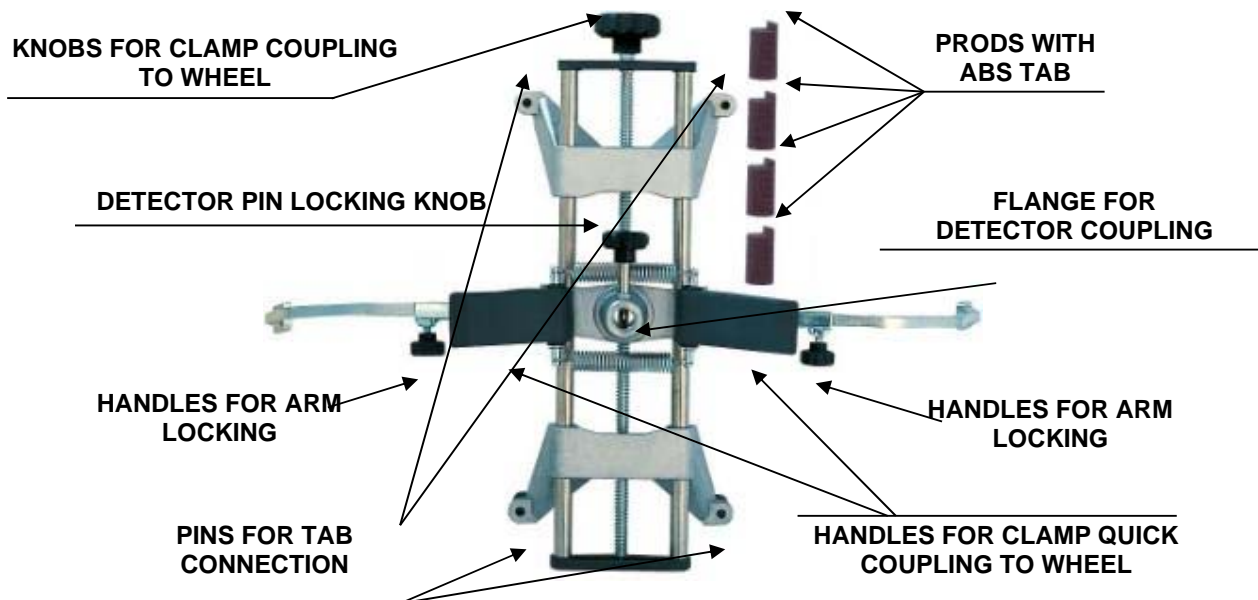

Figure 9

3.9 Rotating Plates

3.9.1 Rotating Plates S110A7

Rotating plates S110A7 have a disc diameter of 250 mm, and a loading capacity of 1,000 kg.

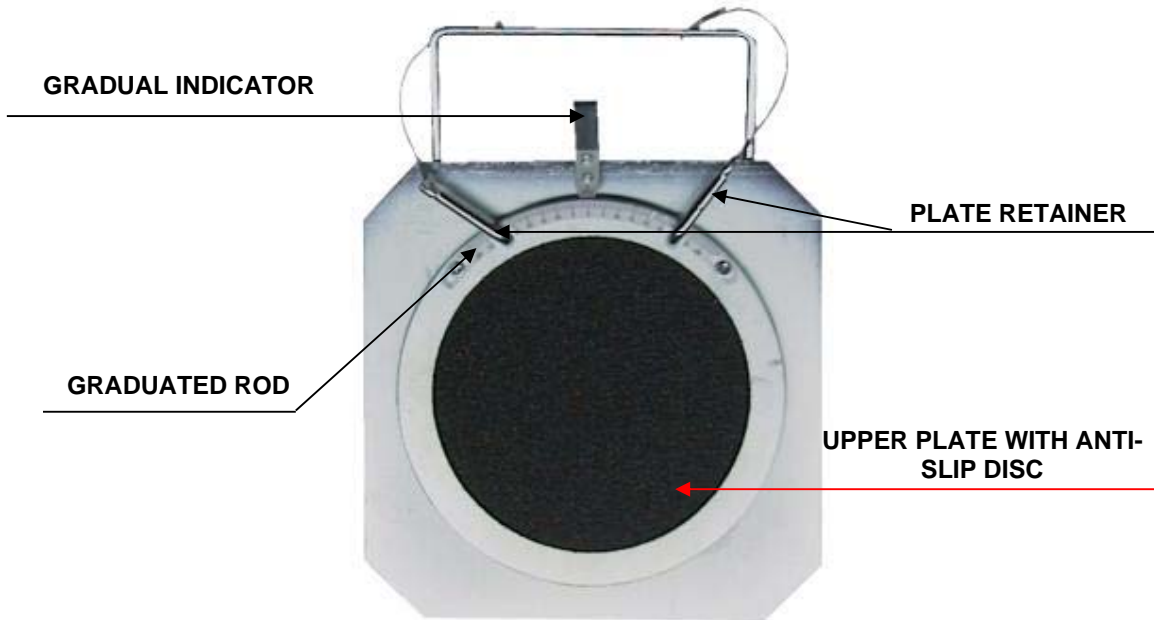

Figure 10

3.9.2 Electronic Rotating Plates Connected to Detectors with STDS43 Via Radio Transmission (for ARS680WS models only)

Electronic rotating plates STDA43 have a 300 mm anti-slip disc, and a loading capacity of 1,250 kg.

They require a low rotating torque and, as they feature an encoder, provide a high resolution.

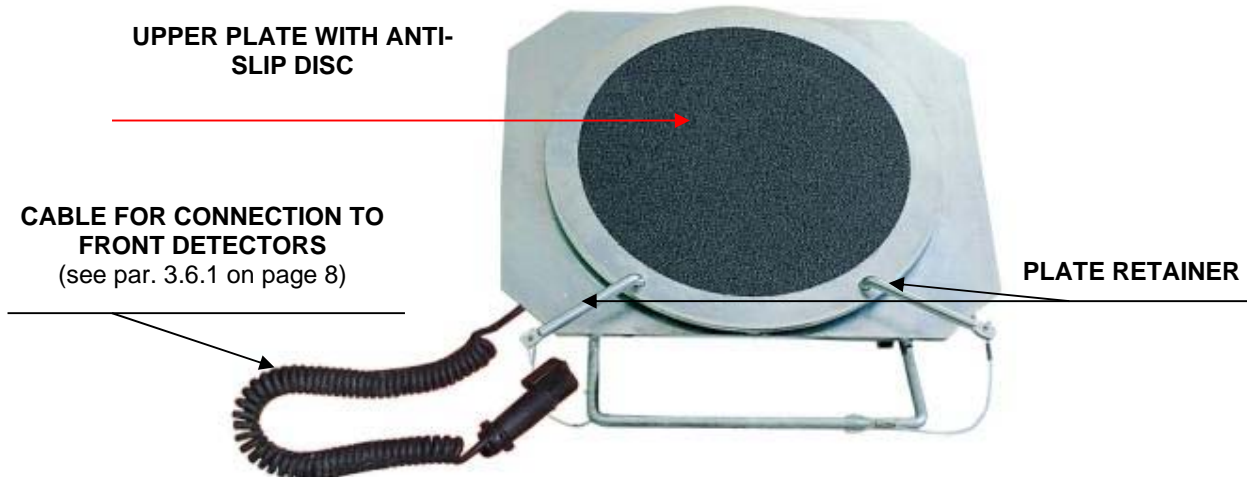

Figure 11

4 SWITCHING THE MACHINE ON AND OFF



WARNING: Before switching the machine on, make sure that the **SMART CARD** for programme enabling and the database are in the special reader on PC front side.
See chap. 10.

4.1 Switching the Machine On

To switch the machine on and to gain access to the programme, turn the special switch positioned on machine back side.

Once PC initialisation is completed by Windows operating system™, programme will be automatically enabled and the introduction page will be displayed. From this page you can enable all machine functions (see par. 8 on page 19).



Figure 12

4.2 Switching the Machine Off

From the introduction page (see par. 8 on page 19) you can switch the machine off by selecting the corresponding key.









	DETECTOR KEYPAD	PC KEYBOARD	DESCRIPTION
			It enables machine switching off procedure request



Figure 13

	DETECTOR KEYPAD	PC KEYBOARD	DESCRIPTION
			It cancels. It goes back to the introduction page. (par. 8 on page19)
			Final confirmation of machine switching off

You have to wait for a few seconds. Then turn the machine off with the switch positioned on machine back side.



WARNING:

The switching off procedure does not affect detector recharge supports, which continue being powered.

5 DETECTORS AUTOMATIC SWITCHING OFF

When the introduction page is displayed, system makes all detectors automatically switch off. Detectors will anyway automatically switch off after 5 minutes approx. if no data are received (ex. cabin is off).

It is anyway recommended to always switch detectors manually off (see par. 3.6.4 on page 9) when they are not used.

6 FLAT BATTERY INDICATION

System displays a flat battery warning signal (Figure 14).

This signal is also visible on the detector through the flashing of start RED LED (see par. 3.6.4 on page 9).

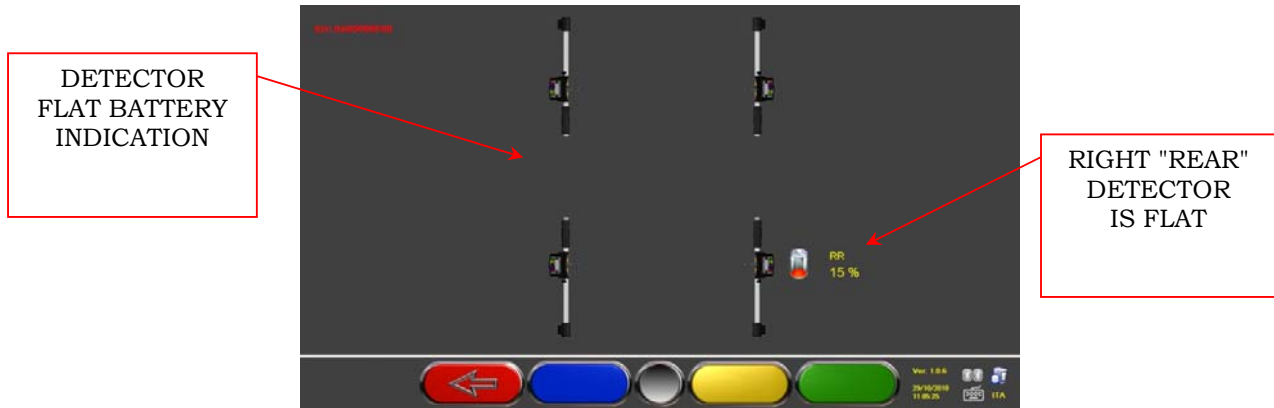



Figure 14

When the residual charge is LOWER than or EQUAL to 30%, system displays the page of flat battery indication (Figure 14). Detector will automatically switch off after a few minutes. Try not to reach this condition, and charge detectors as soon as possible.

To quit the signal page, press F1  .

7 PROGRAMME CONFIGURATION

To proceed to programme configuration, select F2  from the introduction page, as explained in par. 8.1 on page 19.

You will enter a configuration menu allowing editing the different programme characteristics according to your needs.



Figure 15

Language selection: You can select your dialogue language among the many available ones.

Configuration: programme will display the screen of Figure 16













You can edit system parameters, database profile, specify which parts are fitted on the machine, parts type, make a Bluetooth search to couple detectors with cabin.

Print Menu: Print can be customised by entering workshop data, selecting the type of desired printout, and selecting the pre-set printer (if more than one printer is connected).

Backup / Restore: In order not to run the risk to lose any vehicle and customer database data, it is recommended to create a backup copy (data saving). We recommend using a "flash disk" USB key for this process.

Lost or deleted data can be restored if the backup operation has been carried out, thanks to the restore procedure.

Additional functions: programme displays screen Figure 67, from which you can access TEST or sensor Calibration applications (reserved to skilled and authorised personnel), and the "DATABASE MANAGEMENT", see chap. 10

	DETECTOR KEYPAD	PC KEYBOARD	DESCRIPTION
			It goes back to the introduction page. (par.8.1 on page19)
			It moves selection up.
			It moves selection down.
			It confirms selection.

7.1 DATABASE Groups Configuration

Select "GROUPS CONFIGURATION" from program configuration page, as explained in par. 7 on page 16.

You can edit system parameters, database profile, and specify which parts are fitted on the machine, and parts type as well.

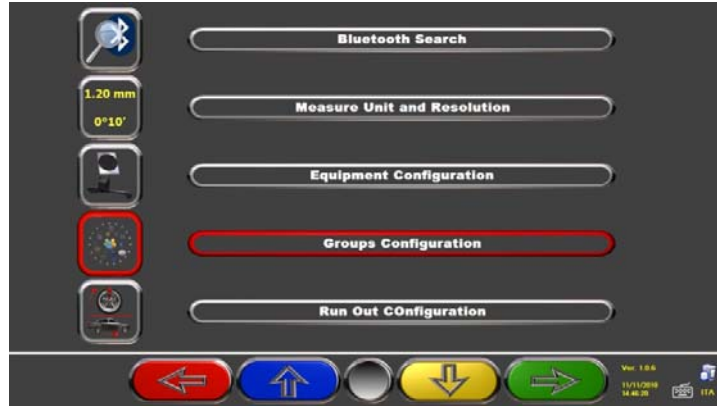

















Figure 16

	DETECTOR KEYPAD	PC KEYBOARD	DESCRIPTION
			It goes back to the start configuration page. (par.8.1 on page19)
			It moves selection up.
			It moves selection down.
			It confirms selection.

Select "DATABASE" option, and confirm. The following screen will be displayed:



Figure 17

	DETECTOR KEYPAD	PC KEYBOARD	DESCRIPTION
			It goes back to Figure 16
			It moves selection up.
			It hides/displays the different Database profiles.
			It moves selection up, displaying the following profiles.
			It confirms selection.

Page Figure 17 displays a list, with the different DATABASE profiles, including the MAKES of the vehicles circulating in the different countries and regions all over the world.

Using key F5 , you can hide and/or display any profile so as to manage Database according to your needs.

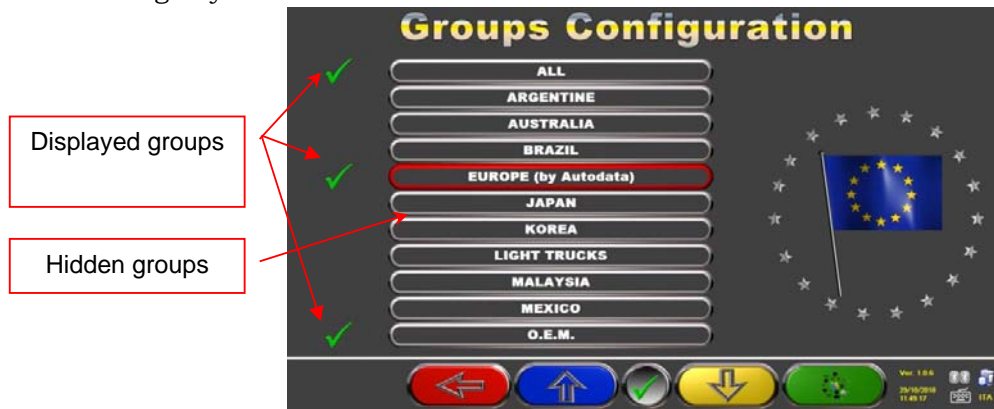



Figure 18

By selecting any group and pressing F4, , you can also customise your profile by hiding and/or displaying the available makes, with key F5 .

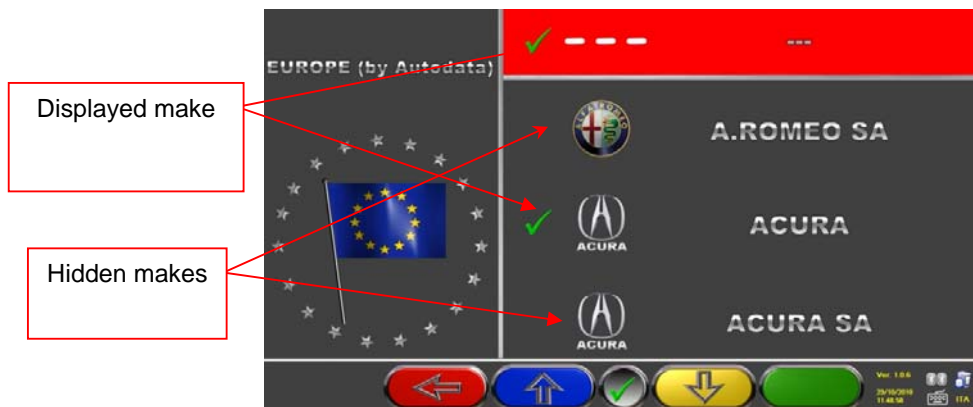

Figure 19

8 VEHICLE DIAGNOSIS AND ADJUSTMENT

8.1 Introduction Page

Upon machine switching on (see par. 4.1 on page13), programme start screen will be displayed. You can select different functions.



Figure 20

	DETECTOR KEYPAD	PC KEYBOARD	DESCRIPTION
			It switches machine off (par.4.2 on page13)
			Programme configuration (par. 7 on page 16)
			It accesses customer database
			It selects the list with different database profiles (par.7.1 on page 17)

Press F4 to continue.

8.2 Vehicle Make and Model Selection



List with different database profiles (par. 7.1 on page 17)

Figure 21

Press F4  to select vehicle make and model. Programme shows the list of the makes of the selected group (see Figure 23),

Or press F5  to start a search using keys (model/make/year) or the V.I.N number (Vehicle Identification Number) which is a unique serial number used by the automobile industry to identify motor vehicles. V.I.N. consists of a 17-alphanumeric digit plate usually positioned inside engine compartment. See Figure 22.

Note: by pressing F5  you select the search mode: Through search keys such as Make name, model/year, or VIN (Figure 22) or through a manual selection (Figure 23).

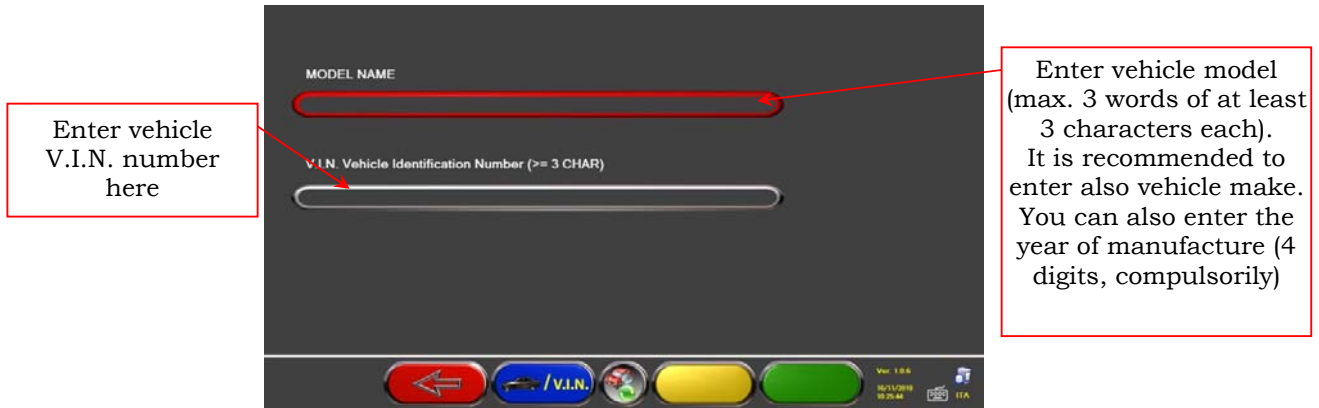



Figure 22

Press  to move cursor from "model name" to "V.I.N." entering field

Press  to continue, and display the list of all the vehicles complying with the just-entered search criteria; then select the correct vehicle and display the page of the selected vehicle technical specifications (par. 8.3)

To select vehicle make and model, press  from the introduction page (Figure 20) or from the database profile page (Figure 21).

The program will display the following box:

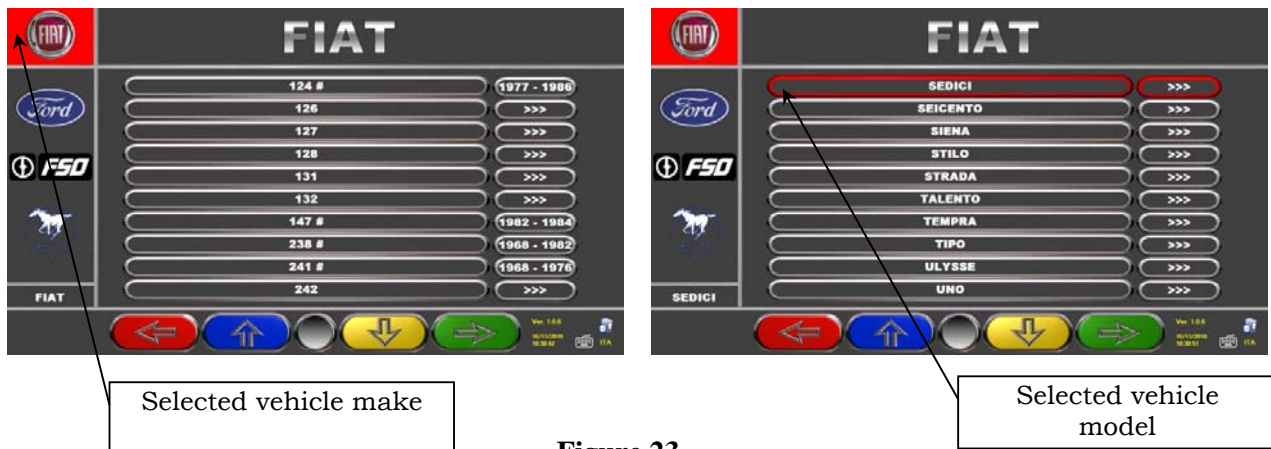







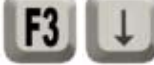









Figure 23

Make and model of the vehicle you are going to work on shall be compulsorily selected.

	DETECTOR KEYPAD	PC KEYBOARD	DESCRIPTION
			It goes back to the introduction page. (par.8.1 on page19)
			It moves selection up.
			It moves selection down.
			It confirms selection and goes to the following phase
			It moves selection up by one page.
			It moves selection down by one page.
			It moves selection to list top.
			It moves selection to list bottom.

NOTE: To speed-up selection phase, you can type the name of vehicle make or model, or part of them, on the PC keyboard, and then scroll the list until finding the desired one.

8.3 Selected Vehicle Technical Specification Displaying

When a vehicle is selected (see par. 8.2 on page 19), a screen showing the measurements and tolerances supplied by the manufacturer is displayed.



Figure 24

	DETECTOR KEYPAD	PC KEYBOARD	DESCRIPTION
			It goes back to vehicle selection (par. 8.2 on page 19)
			Possibility to enter chassis height or kingpin data, as envisaged by the manufacturer
			It displays vehicle technical specifications next page
			It changes rim diameter value
			It goes to preliminary operations (par. 8.4 on page 23)

8.4 Preliminary Operations

8.4.1 Vehicle Check Preliminary Operations

Before starting the check of vehicle geometrical alignment, the following checks shall be carried out:

- Check and, if necessary, eliminate any clearance on suspensions and on steering linkage
- Check and, if necessary, eliminate any hard spot or yielding of suspension spring parts.
- Adjust tyre pressure to the values specified by the manufacturer.
- Position and distribute any load envisaged by the manufacturer.









8.4.2 Run-Out Preparation

After having displayed vehicle technical specification page (see par. 8.3 on page 22), you can prepare vehicle for Run-Out procedure. Proceed as follows:

- Fit clamps and detectors onto wheels
- Raise vehicle from lift platforms (if an Run-Out with raised wheel is carried out, see par. 8.5.1)
- Lock rotating plates



Figure 25

	DETECTOR KEYPAD	PC KEYBOARD	DESCRIPTION
			It goes back to previous page
			Raised wheel Run-Out selection (par. 8.5.1 on page 24) or thrust Run-Out (par. 8.5.2 on page 27)
			It continues to next page (Run-Out) (par. 8.5 on page 24)

Note: during this phase, the images showing the 4 sensor batteries with the residual charge % are displayed.

8.5 Run-Out

The Run-Out procedure proves useful to compensate for rims and clamps unbalance. This procedure can be skipped by pressing F4.

This procedure can be enabled also after having diagnosed the vehicle, by selecting the special option from menu (see chap. 8.13 - Preliminary Operations).

To carry out the Run-Out procedure, you should have performed the preliminary operations, as explained in par. 8.4.2 on page 23.

8.5.1 Run-Out with Raised Wheels

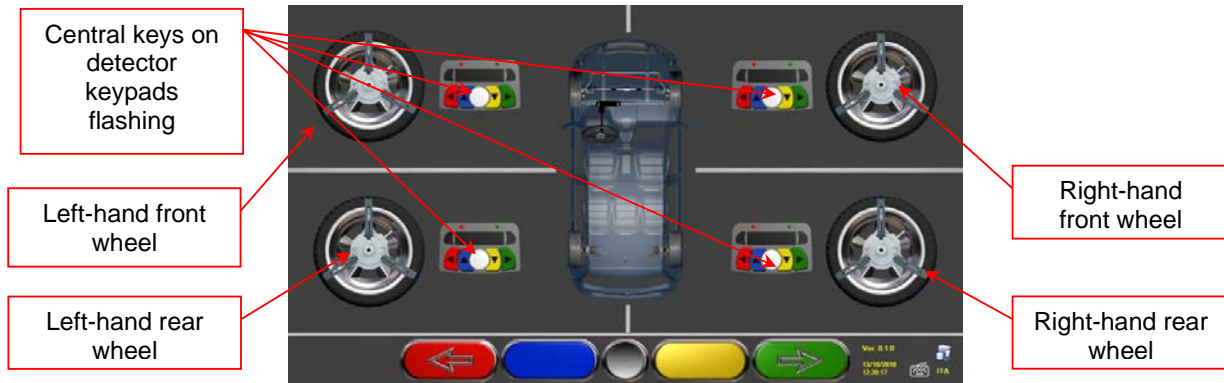







Figure 26

	DETECTOR KEYPAD	PC KEYPAD	DESCRIPTION
			It goes back to Run-Out preliminary operations (par.8.4.2 on page23)
			Make measurement preliminary operations (par 8.6. on page 32)

It is recommended to thoroughly comply with the displayed instructions.

During the start phase, the central keys of the displayed keypads are flashing, to indicate which key has to be pressed to start the procedure. It is neither necessary to start from a special wheel, nor to proceed according to a defined key order (see Figure 26).

The procedure should be carried out on all four wheels so, on the monitor, detector keypad central keys will flash so as to suggest that you start the procedure by pressing the special key (see Figure 26). During configuration, you can set the Run-Out procedure in 2 or 3 points. The example shows a 3-point procedure.

When keypad central key is pressed, the following screen will be displayed:

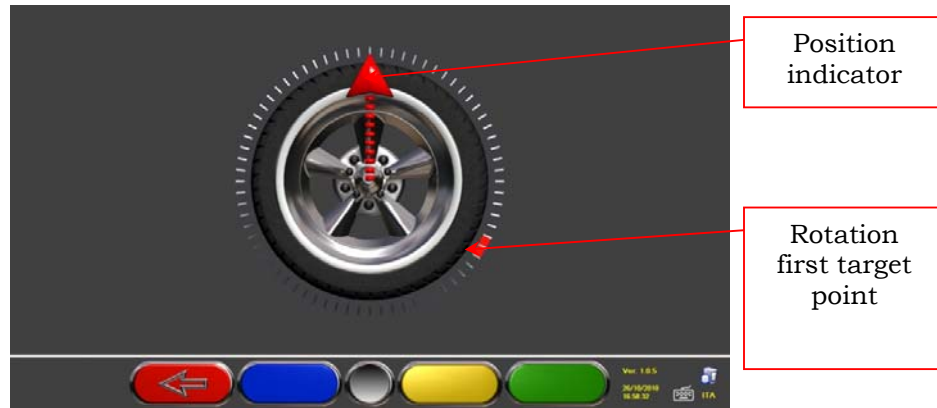

Figure 27

Figure 27 shows wheel current position.

Upon procedure start, a “self-calibration” is carried out so that the position indicator is facing up. Turn wheel rim by hand so as to allow the real-time displaying of wheel position and of the corresponding position indicator. Update is made approx. every 3 times a second. The first target is to turn wheel by 120° and reach the first highlighted point. Rotation can be made in both directions, but it is nevertheless recommended to follow the direction shown by the arrow to reach the indicated position more quickly.

Turn wheel by 120° and, once the target position is reached, press detector keypad central key, as indicated on the screen Figure 28.



Figure 28

Figure 29 is displayed for approx. three seconds, which are enough for the programme to acquire measurement readings. The red LED previously flashing on detector keypad (par. 3.6.4 on page 9) will turn off during data acquisition; then it will flash again:



Figure 29

Now you shall turn wheel until position indicator matches the second point, positioned at about 240° from the starting position.

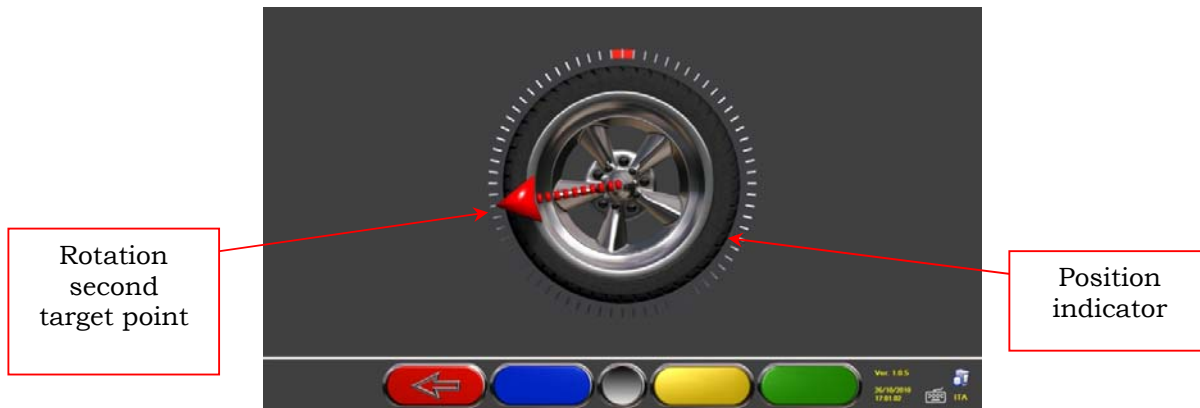

Figure 30

Turn wheel by 240° and, once the target position is reached, press detector keypad central key, as indicated on the screen Figure 28.

The last phase consists in taking wheel back to the starting point: third point. Once last rotation (to go back to starting position) has been carried out, programme acquires the last measurement readings. The screen Figure 29 will be displayed again for approx. three seconds. After measurement acquisition, programme will automatically continue, and the following screen will be displayed:

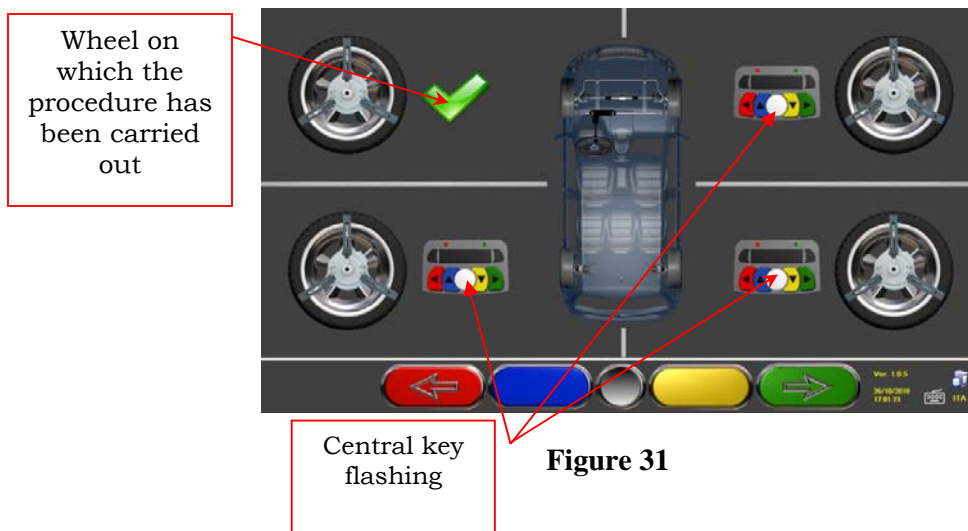

Figure 31

On Figure 31 the front left wheel is shown with a tick on the side, to indicate that the procedure has been carried out on that wheel. Procedure can anyway be repeated by pressing again the central key of the concerned detector. When the Run-Out procedure has been completed on all wheels, programme will automatically go to the next phase.

NOTE: Watching the monitor during this procedure could sometimes prove difficult, mainly when working on rear wheels. To prevent this problem, the Run-Out three acquisition points can be easily associated to the position of the 3 clamp arms (if made on 3 points) or to the 2 clamp sides with 4 points (if made on 2 points).

The different phases can be followed by looking at the red LED on the keypad of each detector:
 Red LED flashes when wheel has to be turned.
 Red LED turns off when one of the three points is being sampled
 Red LED is steady when the procedure has been completed.

NOTE 2 : During system configuration, you can also define that procedure is carried out on 2 points instead of 3. This means that wheel will be turned twice by 180°, instead of being turned three times by 120°, as described above.

8.5.2 Thrust Run-Out with Automatic Acquisition

To carry out the thrust Run-Out with automatic acquisition procedure, press F3 to select

“thrust Run-Out” during the preliminary operations (see par. 8.4.2 on page 23)  .
 The following screen will be displayed:

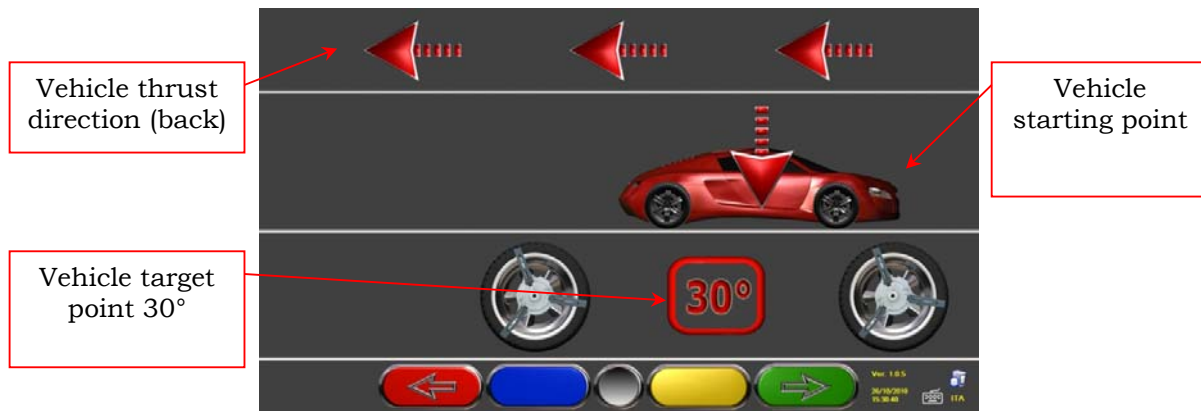

Figure 32

To carry out the thrust Run-Out operation, it is recommended to carefully follow the displayed instructions.

RELEASE detectors, so that they are free to oscillate upon wheel movement. Wait for detectors to stop oscillating, and start moving vehicle backwards, very slowly, until the rotation of the wheel has turned 30 degrees. You can observe this rotation on the 3-point races of the clamps.

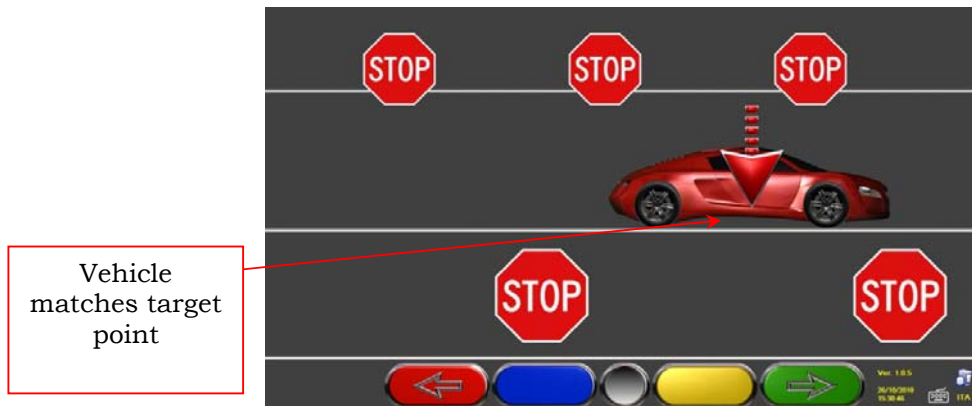

Figure 33

As soon as vehicle matches target point, wait for detectors to stop oscillating. "STOP" will be displayed for approx. three seconds, which are enough for the programme to acquire measurement readings. Then the following screen will be displayed:

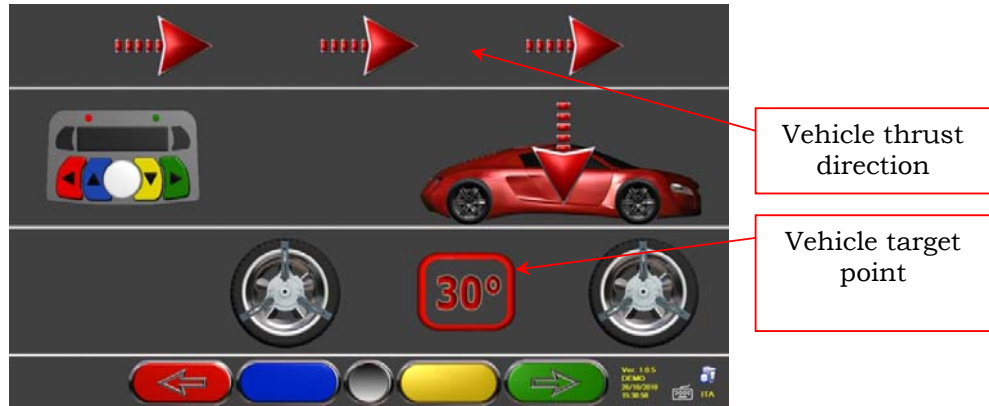

Figure 34

Move vehicle forward again, until the rotation of the wheel did not make back 30 degrees forward (final point). "STOP" will be displayed for approx. three seconds, and measurement readings acquired. The thrust Run-Out procedure has been completed.

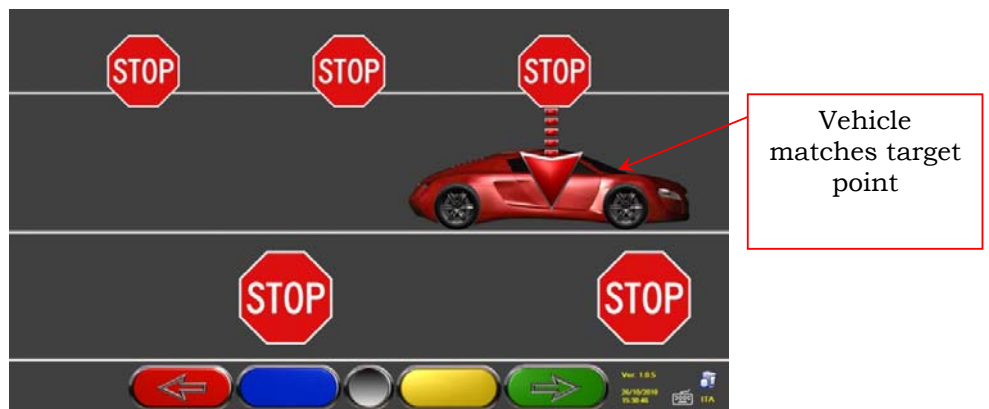

Figure 35

Should you be willing to repeat the operation once the programme has already entered a following phase, you can go back to this page by pressing F1, and repeat the above procedure. Once the Run-Out procedure has been completed, programme will automatically go to the next phase.

8.5.1 Inclinometer-controlled Thrust Run-Out

Inclinometer control during the thrust Run-Out procedure is used to measure more accurately the rotation angle pertaining to the calculation.

From the Run-Out configuration menu, set – Thrust Run-Out → “inclinometer”.

Lower the reference detector (usually it is the left front one) until its end is almost touching the ground, then lock it in place. RELEASE the other detectors, so that they are free to oscillate upon wheel movement. When finished, press central key to confirm.

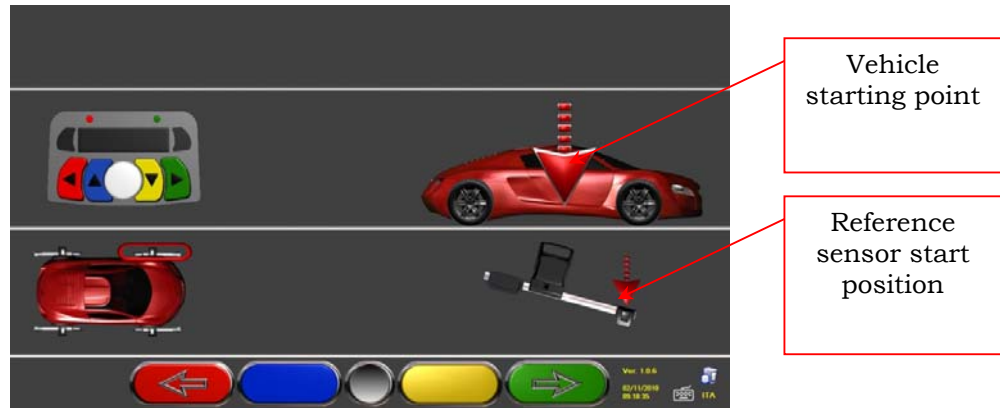

Figure 36

Move vehicle back, very slowly, until reference sensor reaches the target position (end up - see Figure 37). When finished, press central key to confirm.

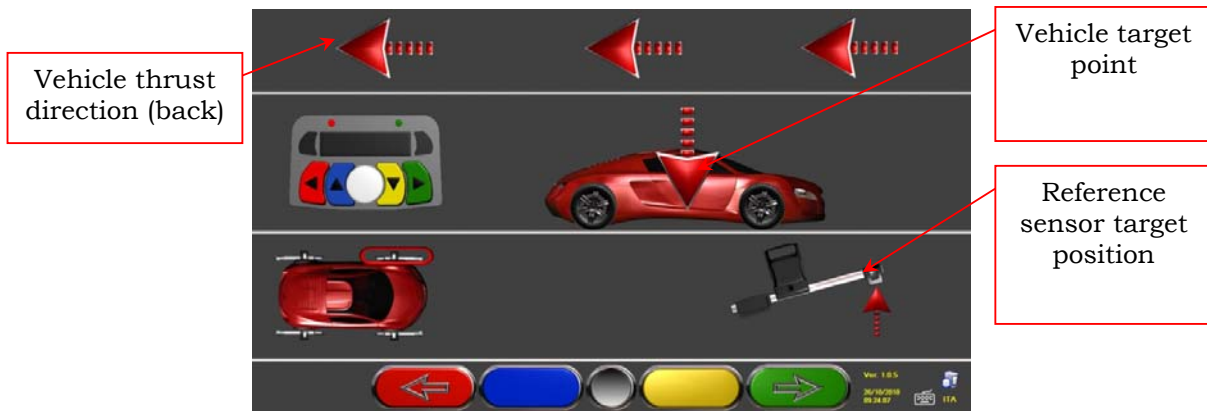

Figure 37

Position reference sensor horizontally - clearly levelled - and, when finished, press central key to confirm.

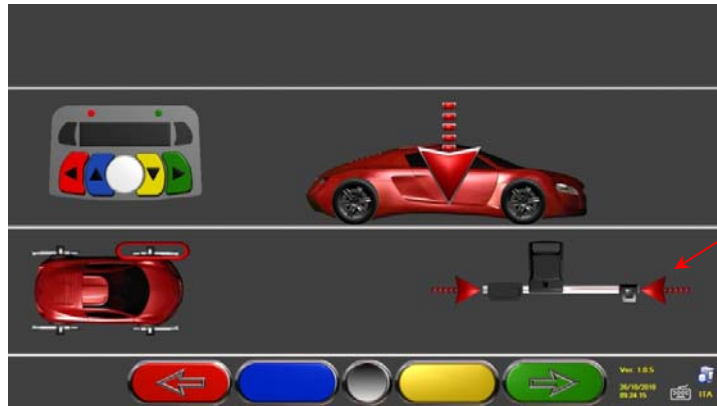

Figure 38

“STOP” is displayed for approx. three seconds, which is enough for the programme to acquire measurement readings.

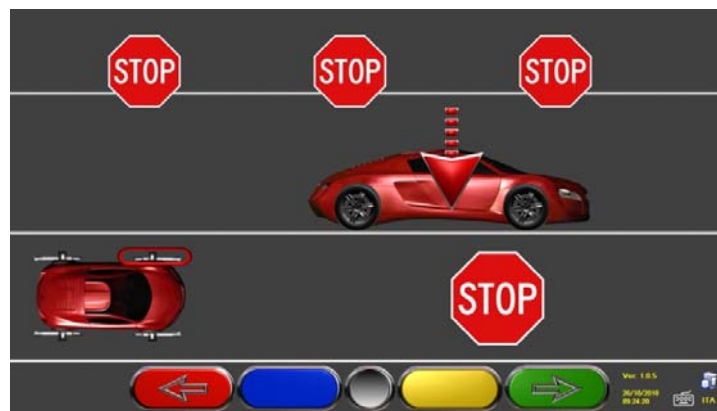

Figure 39

Position reference sensor again with the end up, almost in the "target" position reached in Figure 47 and, when finished, press central key to confirm.



Figure 40

Move vehicle forward, very slowly, until reference sensor reaches again almost the start position. When finished, press central key to confirm.

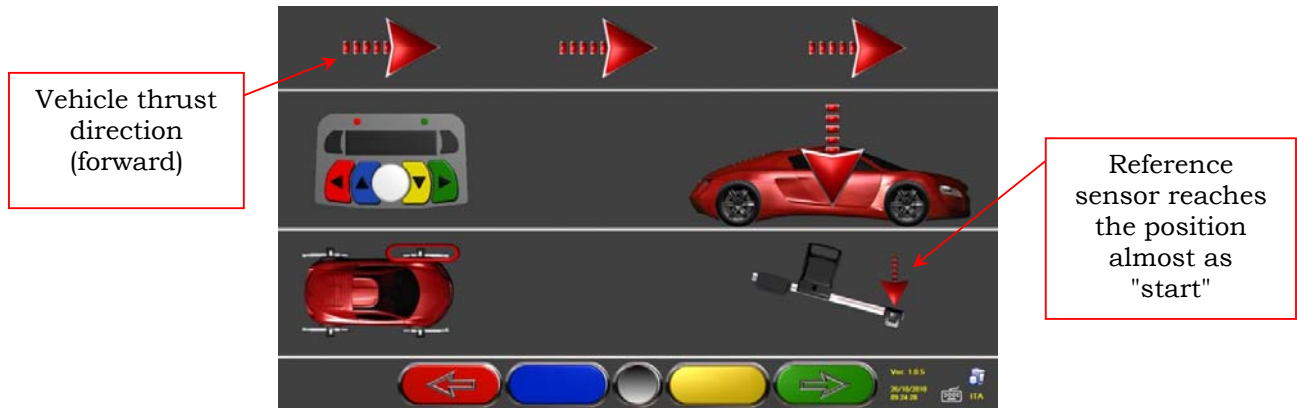

Figure 41

Position reference sensor horizontally - clearly levelled - and, when finished, press central key to confirm.
“STOP” is displayed for approx. three seconds, which is enough for the programme to acquire measurement readings.

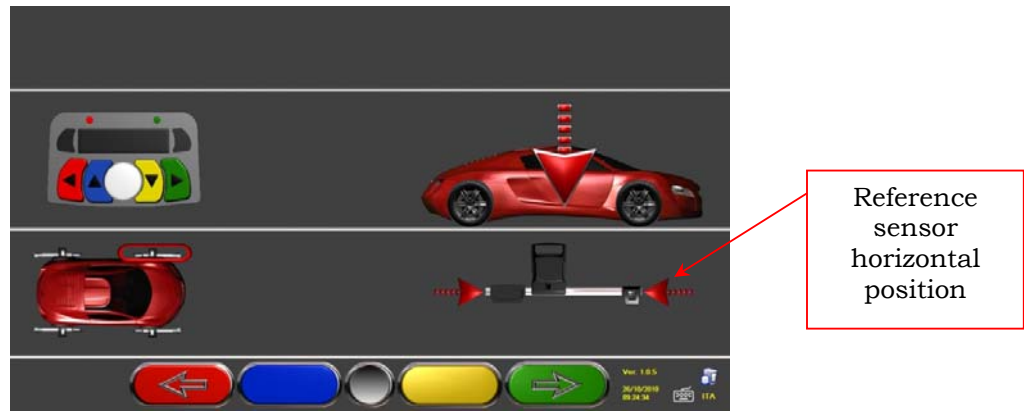

Figure 42

The thrust Run-Out procedure with “inclinometer control” has been carried out.

Should you be willing to repeat the operation once the programme has already entered a following phase, you can go back to this page by pressing F1, and repeat the above procedure. Once the Run-Out procedure has been completed, programme will automatically go to the next phase.

8.6 Measurement Preliminary Operations

After having carried out the Run-Out procedure as explained in par. 8.5 on page 24, vehicle shall be prepared for measurement readings. The following screen will be displayed:

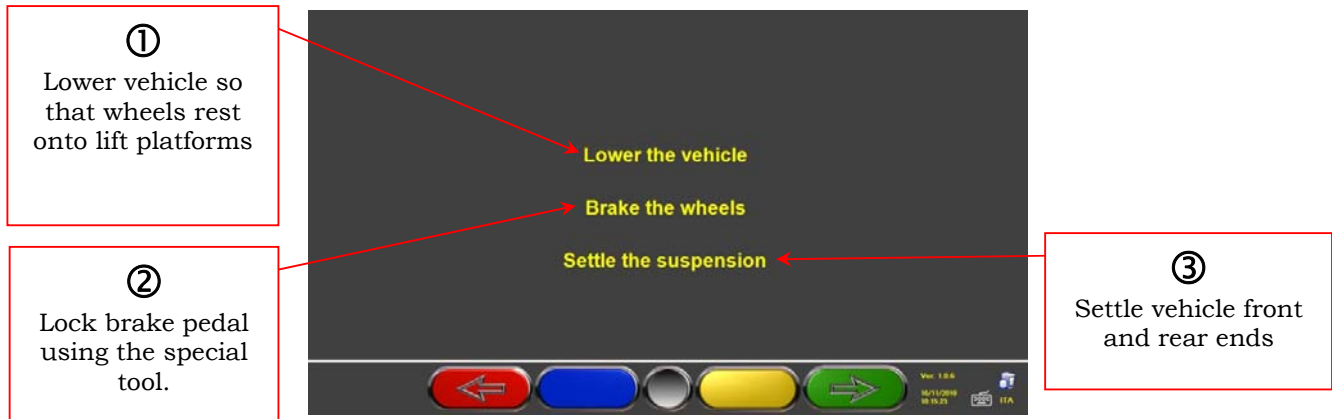







Figure 43

	DETECTOR KEYPAD	PC KEYBOARD	DESCRIPTION
			It goes back to Run-Out procedure (par. 8.5 on page 24)
			It continues to the alignment procedure (par. 8.7 on page 33)

- 1) Lower vehicle so as to make wheels rest on lift platforms (of course, only if the Run-Out procedure has been carried out with raised wheels)
- 2) Release front plates, and any rear platform
- 3) Brake wheels with hand brake, and lock brake pedal with the special tool (this operation is necessary when carrying out a steering for kingpin correct calculation).
- 4) Settle vehicle front and rear ends (this operation shall be carried out only if the Run-Out with raised wheels procedure has been performed).



Press  to continue.

8.7 Detectors Alignment and Levelling

To proceed to detectors alignment and levelling procedure, you should have first carried out measurement preliminary operations, as explained in par. 8.6 on page32 .



Figure 44

	DETECTOR KEYPAD	PC KEYBOARD	DESCRIPTION
			It goes back to measurement preliminary operations. (par. 8.6 on page 32)

Turn steering wheel from left to right, or vice-versa, until wheels are aligned, namely until display level is not perfectly centred.

Adjust detectors until they are levelled, and lock them in place by turning the special knobs. This operation shall be carried out on all four detectors.

If front wheels are too misaligned, no levelling will be displayed.

NOTE: Once detector alignment and levelling operations are completed, the “STOP” images will be displayed under the alignment level to indicate that the programme is acquiring vehicle data measurements. Now also detector calibration check is carried out. Programme will automatically continue only after detectors are correctly aligned and levelled.

WARNING: The vehicle being diagnosed could feature a front spoiler preventing communication among detectors. Should this be the case, the special “spoiler” procedure will be automatically started.

Follow the displayed graphic representation, and lower front sensors so that the transducers positioned onto arm end are below the spoiler. System acquires front toe measurement, and then the alignment and levelling procedure of Figure 44 will be displayed again. Align and level, the programme will continue automatically.

8.8 Steering Procedure

Once detectors are aligned and levelled (see par. 8.7 on page 33), the steering procedure can be carried out in order to define:

- Caster
- Kingpin
- Included angle

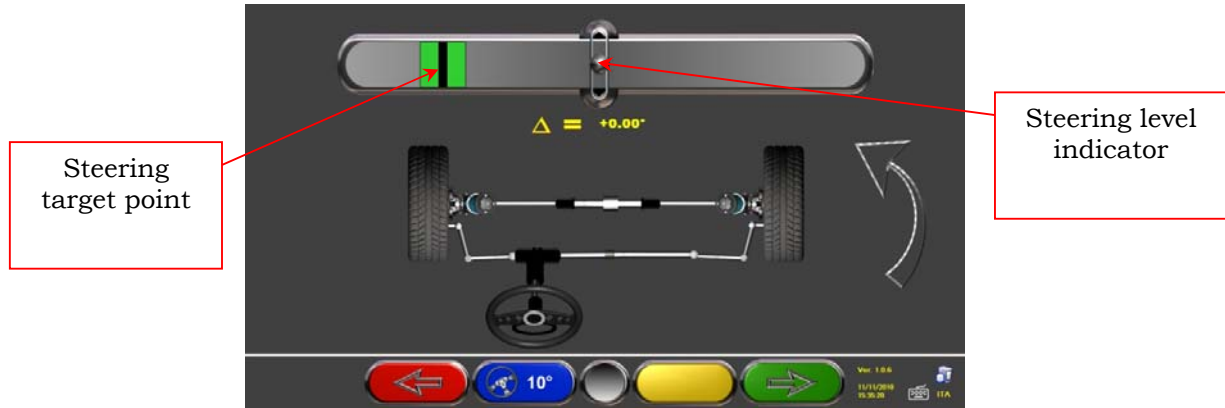

Figure 45

	DETECTOR KEYPAD	PC KEYBOARD	DESCRIPTION
			Repeat alignment and levelling procedure (par. 8.7 on page 33)
			Press this key to select the type of steering to be made. (*)
			It displays vehicle diagnosis page (par. 8.9 on page 35)

(*) Type of steering to be made:

- Steering at 20°
- ACK steering (at 20° with Toe-out on turn)
- Steering at 10°
- Max. steering with rotating plates with ENCODER (optional – for ARS680WS models only)

Steering procedure can also be skipped: the values of the above-specified data measurements will not be available. To skip the procedure, press F4 to directly display vehicle diagnosis page.

Should the procedure not be carried out at this stage but only at the end of adjustments, you can select the corresponding option from the menu.

8.9 Vehicle Diagnosis

After having carried out the steering procedure (see par. 8.8 on page 34), a diagnosis page showing a summary of the operations carried out on vehicle rear axle (Figure 46) will be displayed.



Figure 46

	DETECTOR KEYPAD	PC KEYBOARD	DESCRIPTION
		F1 ←	Repeat steering procedure. (par. 8.8 on page34)
		F2	It changes values displaying layout
		F3	It displays vehicle technical specifications (it may be changed, if needed). (par. 8.3 on page22)
		F4 → ↩	It displays diagnosis page with a summary of front axle measurements (Figure 47)

Press F4 to display the diagnosis page with a summary of front axle measurements (Figure 47). If you press F3 from here , programme will allow the printout of diagnosis measurements.

Press F4 to continue with data adjustment, programme will display Figure 48, press F4 again to confirm.



Figure 47



Figure 48

Now you can prepare vehicle for adjustment (see par. 8.10 on page 36), confirm with F4 (Figure 48).

8.10 Adjustment Preliminary Operations

Select F4 from Figure 48 (see par. 8.9 on page 35) to carry out adjustment preliminary operations. Follow the displayed instructions to carry out adjustment preliminary operations. Press F4 to continue.

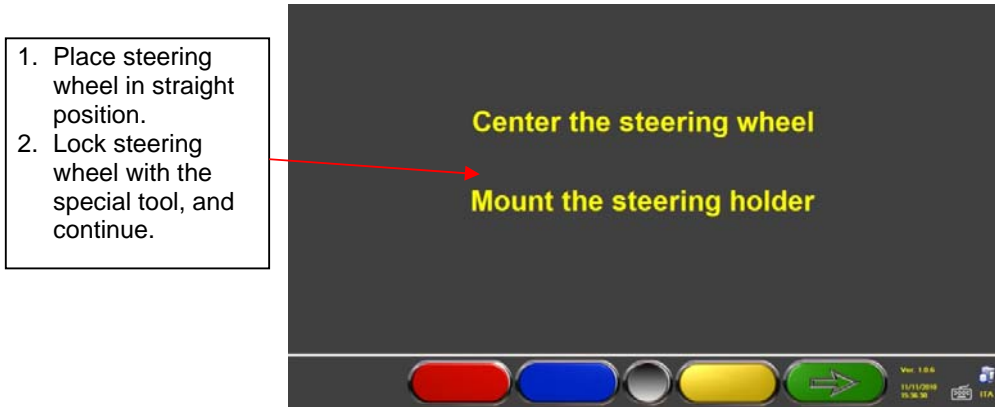

Figure 49

8.11 Rear Axle Adjustment

Rear axle adjustment procedure can be made by pressing F4 from Figure 49 after having carried out adjustment preliminary operations (par. 8.10 on page 36).

Proceed to adjustment, where allowed, as follows:

- Rear camber - Rear partial toe

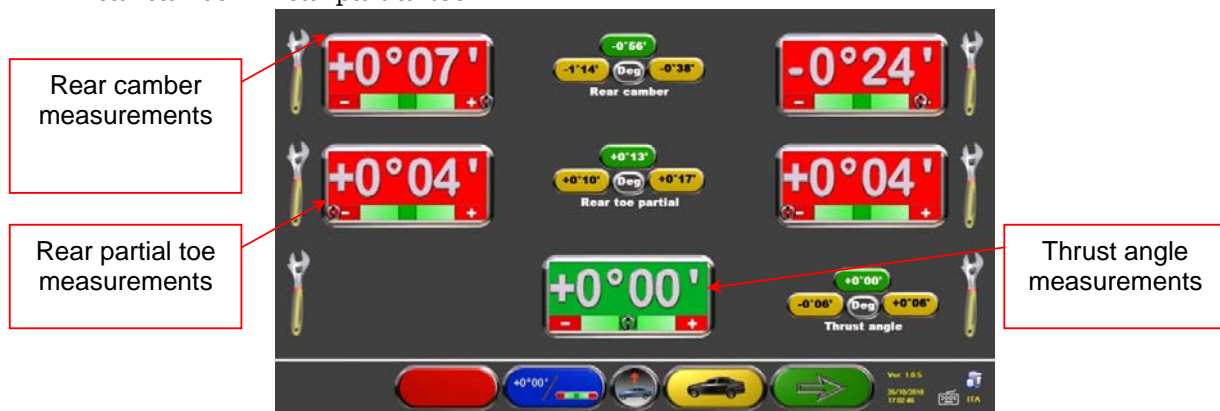

Figure 50

	DETECTOR KEYPAD	PC KEYBOARD	DESCRIPTION
			It changes values displaying layout (large numbers/large cursors)
			“Jack-Hold” procedure (adjustment with raised wheels)
			It displays vehicle technical specification page. (par. 8.3 on page 22)
			It continues to front axle adjustment. (par. 8.12 on page 37)

8.12 Front Axle Adjustment

Front axle adjustment procedure is launched by selecting in the rear axle adjustment page (Figure 52) after having carried out adjustment preliminary operations (see par. 8.10 on page 36).

To adjust angles, the correct sequence is the following: CASTER – CAMBER – TOE.

WARNING: When entering this stage, caster values are “FROZEN”.

To “de-freeze” these values, you can press Shift+F5 at the same time when the measurement selection “R” is on caster measurement values, or select F2 to display a menu page with additional functions (par. 8.13 on page 38). Now select “Caster Adjustment”.

Once caster values have been adjusted or, even if they are not adjusted as they are deemed to be correct, it is recommended to “FREEZE” again these values. This procedure prevents caster values from varying in case detectors are inadvertently moved.

To this end, take measurement selection “R” (see Figure 51) onto the caster values, and proceed as described above.

A grid will be displayed onto caster values, to indicate that they are “frozen”.

Then adjust front axle



Figure 51

	DETECTOR KEYPAD	PC KEYBOARD	DESCRIPTION
			Repeat steering procedure. (par. 8.8 on page34)
			It displays options menu. (par. 8.13 on page 38)
			Selection key of the measurement to be adjusted.
			Operations completed ! Customer data entry (par. 8.14 on page 39)
			It repeats adjustment operations (par. 8.11 on page 36)

8.13 Additional Functions Menu

To carry out some additional operations or to repeat some of programme phases (in case they have not given satisfactory outcomes or have not been carried out at all), select F3  from the FRONT AXLE ADJUSTMENT page (see par. 8.12 on page 37).

You will access an additional function menu allowing carrying out the following procedures:

PRELIMINARY OPERATIONS: see par. 8.4.1 on page 23

TOE CURVE: Toe curve can be adjusted by following the displayed figures, as follows:

- Settle vehicle, press F4
- Position the special tool under front axle, press F4
- Adjust front partial toe, as recommended by the manufacturer, press F4
- Remove tool from axle, and press F4. Programme will go back to the adjustment phase.











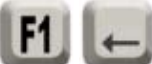

CHASSIS DIAGNOSIS: A graphic-geometrical representation of the axles of the vehicles you are working on can be displayed.

DATABASE: It allows displaying vehicle selection page (8.2 on page 19) and, if needed, selecting a different vehicle

CASTER ADJUSTMENT: see par. 8.12 on page 37.

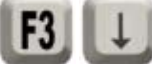

Figure 52

	DETECTOR KEYPAD	PC KEYBOARD	DESCRIPTION
			It goes back to front adjustment page (par 8.12. on page 37)
			It moves selection up.
			It moves selection down.
			It confirms selection.

8.14 Printout of Measurements taken

By selecting the following key from the customer data entry page, the following screen will be displayed:



the following screen will be displayed:

Adjustment

Customer* **Rossella MANZONE**

Reg. number* **DJ452AS**

Chassis n. **12054**

Km **28600**

Note

Ver. 1.0.6
11/11/2010
15.38.25

Figure 53

	DETECTOR KEYPAD	PC KEYBOARD	DESCRIPTION
			Repeat steering procedure. (par. 8.8 on page 34)
			It stores the carried out diagnosis inside a special "customer database" so as to allow test later displaying (par. 8.13 on page 38)
			It displays a print preview of the test carried out (par. 8.14 on page 39)
			It goes back to start page without storing test

ARS680 WS











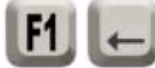

Customer: Rossella MANZONE Date: 11/11/2010 13:38
 Reg. number: DJ452AS Vehicle: SEEDS (2006 - ...)
 Vehicle make: FIAT Km done: 17'

Front axle		Nominal values	Diagnosis	Adjustment
	Steering	0°	-0.50°	-0.50°
	Front toe	0%	-0.50°	-0.50°
	Front toe per side	0%	-0.50°	-0.50°
	Front camber	0%	-0.50°	-0.50°
	Camber	0%	-0.50°	-0.50°
	Kingpin	0%	-0.50°	-0.50°
	Kingpin angle	0%	-0.50°	-0.50°
	Steering axis inclination (SAI)	0%	-0.50°	-0.50°
	SAI	0%	-0.50°	-0.50°
	SAI angle	0%	-0.50°	-0.50°

Rear axle		Nominal values	Diagnosis	Adjustment
	Steering	0°	-0.50°	-0.50°
	Rear toe per side	0%	-0.50°	-0.50°
	Rear camber	0%	-0.50°	-0.50°
	Steering axis inclination (SAI)	0%	-0.50°	-0.50°
	SAI	0%	-0.50°	-0.50°
	SAI angle	0%	-0.50°	-0.50°

Ver. 1.0.6
11/11/2010
15.38.41

Figure 54

	DETECTOR KEYPAD	PC KEYBOARD	DESCRIPTION
			It goes back to “vehicle data entry” phase of Figure 53
			It allows selecting a printer different from the pre-set one
			It sends print report to printer
			It allows defining colours on the printout of out-of-tolerance data (Red to highlight them or Black NOT to highlight them)

A report on the performed test is printed with customer data, vehicle data before and after adjustment, vehicle technical specifications supplied by manufacturer, and any other remarks for the customer.

To access the data contained inside customer database, press F3  from the start page (see Figure 20)

Legend of the printout example shown in the previous page (Figure 55).

- 1 - ATLAS logo of the manufacturer
- 2 - Space dedicated to workshop data customisation
- 3 - Test date and time
- 4 - Vehicle being tested and vehicle owner data
- 5 - Vehicle being tested manufacturing data
- 6 - Vehicle being tested diagnosis data
- 7 - Vehicle being tested data after adjustment
- 8 - Front axle data table
- 9 - Rear axle data table
- 10 - Space devoted to manual remarks



ARS680 WS

Customer :
Reg. number :
Vehicle make :
Km :

Rossella MANZONE
DJ452AS
FIAT
28600

Date :
Vehicle :
Rim diam.

11/11/2010 15:39

SEDICI (2006 - ---)
17"

Front axle



Nominal values



Diagnosis



Adjustment



Total toe	Dg	-0,34°	-0,28°	-0,20°	+0,31°	-0,80°	+0,56°	+0,75°
Ft. toe partial	Dg	-0,17°	-0,14°	-0,10°	+0,73°	+0,49°	+0,70°	+0,19°
Front camber	Dg	-0,87°	-0,57°	-0,28°	+3,46°	-0,71°	+1,44°	-0,69°
Caster	Dg	+3,95°	+4,25°	+4,55°	+18,18	+2,69°	+0,77°	+3,46°
King-pin	Dg	+11,00	+12,00	+13,00	+18,91	+7,96°	+10,22	+18,18
Incl. angle	Dg	-----	-----	-----	+18,91	+7,25°	+11,66	+18,88
Toe-out on turns (20°)	Dg	+1,35°	+1,85°	+2,35°	+0,47°	+1,62°	+0,47°	+1,62°
Steering in	Dg	+30,00	+32,00	+34,00	---	---	---	---
Steering out	Dg	+36,00	+38,00	+40,00	---	---	---	---

Rear axle



Nominal values



Diagnosis

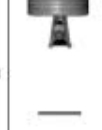

Adjustment



Total toe	Dg	+0,32°	+0,44°	+0,56°	+0,14°	+0,24°	+0,24°	+0,24°
Rear toe partial	Dg	+0,16°	+0,22°	+0,28°	+0,14°	+0,10°	+0,14°	+0,10°
Rear camber	Dg	-1,23°	-0,93°	-0,63°	-0,11°	-0,36°	+0,25°	-0,36°
Thrust angle	Dg	-0,10°	+0,00°	+0,10°	---	+0,02°	---	+0,02°

Figure 55

9 DATABASE CUSTOMISATION

Vehicle database can be customised by creating customised groups and vehicles.

9.1 New Group Entry

To create customised groups and store them inside database, the group configuration page shall be displayed (see par. 7.1 on page 17).

Press “Ins” on the keyboard  .

The following screen will be displayed:



Figure 56

Type the name of the new profile (the example Figure 56 shows “ITALIA”), and press F4 to confirm.



Figure 57

Now press F4 to enter the new “ITALIA” group and display the available makes with F5  , as specified in Figure 19. Then display profile, always pressing F5, as described here below in Figure 58.

Press F1 to quit.



Figure 58

9.2 New Group Deletion

You have to display the group configuration (see par. 7.1 on page 17), select the customised group you want to delete, then press "cancel"  : , and press F4 to confirm.



Figure 59

Warning: If a customised group is deleted, it will no longer be possible to restore it, unless you have a database backup copy.

9.3 New Vehicle Entry

To create customised vehicles and store them inside the database, you shall first of all display the page of the measurements and tolerances supplied by the manufacturer of an already-existing vehicle (see par. 8.3 on page 22).

Press “Ins” on the keyboard :
The following screen will be displayed:





Figure 60

As you can see in Figure 60 on the highlighted point, the make of the selected vehicle is highlighted by a red background.



You can enter or confirm the name of the make of the vehicle you want to create. Then, select and enter:

- Vehicle model and submodel name
- Manufacturing start date
- Manufacturing end date
- Rim diameter
- Front track
- Rear track
- Left wheelbase
- Right wheelbase
- Load conditions
- Tank conditions

Use the following keys for data selection:

	Move selection to the following datum.
	Move selection to the previous datum.

After data entry, you can delete them using the following keys:

	It deletes the whole selected element
	It deletes the last character of the selected element

Once the manufacture end date has been entered and you move on the next datum, the following screen relating to load conditions will be displayed



Figure 61

After having selected rim diameter, the following data to be entered are vehicle track and wheelbase, in the following screen:











Figure 62





Then enter tank and load conditions
Now the screen will look as follows:



Figure 63

	DETECTOR KEYPAD	PC KEYBOARD	DESCRIPTION
			It goes back to the introduction page. (see chap. 8 on page 19)
			It moves selection up.
			It moves selection down.

As you can see from the zoom on the right side of Figure 63, you will have to specify if the point datum refers to can be adjusted or not.

	The point to which the data refer can be adjusted. To define it as not-adjustable, press:	
	The point to which the data refer cannot be adjusted. To define it as adjustable, press:	
Once the desired option has been selected, press:		



Once angle “adjustability” has been specified, you can enter the **graphic animations**.

Select the correct image or animation with keys  , then press “Enter” to confirm 

Now you shall enter vehicle standard tolerance values as for:

FRONT AXLE:	REAR AXLE
<ul style="list-style-type: none"> • Toe • Camber • Caster • Kingpin • Included angle • Max. steering 	<ul style="list-style-type: none"> • Toe • Camber • Thrust angle

Select data as described above, and enter values.

Warning: To separate whole values from decimals, try using a “dot”  or a “comma” .

When you have completed values entering, the following screen will be displayed. You will have to select an option:



Figure 64

Press F4  to confirm and create the customised vehicle.

If vehicle database is displayed, you can observe that also the just-created customised vehicle is present; it is listed under a separate make, in alphabetical order, written in italic.

Using the same procedure, you can edit the values of a customised vehicle without having to create a new one. The final screen will be like the one of Figure 64 with the additional item:

“Edit customised vehicle”

Select this option to edit vehicle data.

9.4 Customised Vehicle Deletion

You have to display vehicle database, and select the customised vehicle you wish to delete,

then press Ctrl + Canc:  + 

Warning: If a customised vehicle is deleted, it will no longer be possible to restore it, unless you have a database backup copy.

10 PROGRAMME AND DATABASE PROTECTION SMART CARD

ARS660WD, ARS680WD and ARS680WS all feature a PC with SMART CARD reader. This SMART CARD, inserted inside reader, allows programme operation, and enables access to vehicle DATABASE.

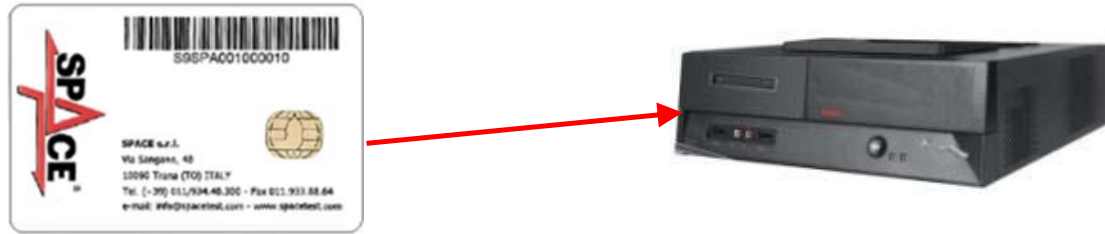

Figure 65

Every machine has its own unique SMARTCARD that cannot be replaced with the SMARTCARD of another machine for whatever reason. Should this SMARTCARD be removed or replaced, programme will display an error message, such as Figure 66, and will not give the authorisation to continue.



Figure 66

Database can be updated by downloading files from Internet. Contact your retailer for further details on the download from the manufacturer's web site.

10.1 DATABASE Management

To update database, proceed as follows:
Select "Database Management" option from programme configuration menu (see chap. 7) as specified in Figure 67, and press F4 to continue.



Figure 67



SMARTCARD serial number

Figure 68



When a USB flash disk key is inserted (such as the one supplied with the machine, and containing system Back-Up), the keys for database management are displayed, as shown in Figure 69.



SMARTCARD serial number

F2 → EXPORT CERTIFICATE

F3 → IMPORT TOKEN (release key)

F4 → IMPORT Database on PC

Figure 69

F2  → Export certificate on USB flash disk. Customer shall send it to the manufacturer so that a release key can be prepared (as an alternative to the communication of customer's SMARTCARD serial number).

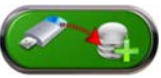
F4  → It allows copying the correct path of the DATABASE file that has been previously downloaded from internet and inserted inside USB flash disk ROOT. Updated databases shall then be released through "Token" import.

F3  → Manufacturer sends the release code (called Token) to the customer after having checked the fulfilment of requirements (such as payment of the new Database). This "Token" file shall be pasted inside USB flash disk ROOT and, by selecting this key, Token is imported in the correct path on your own PC so that the new database is released.

11 DETECTORS' ERRORS

11.1 Data Reception/Transmission Error between Detectors and Cabin

During data transmission/reception between detectors and cabin, the following screen may be displayed:

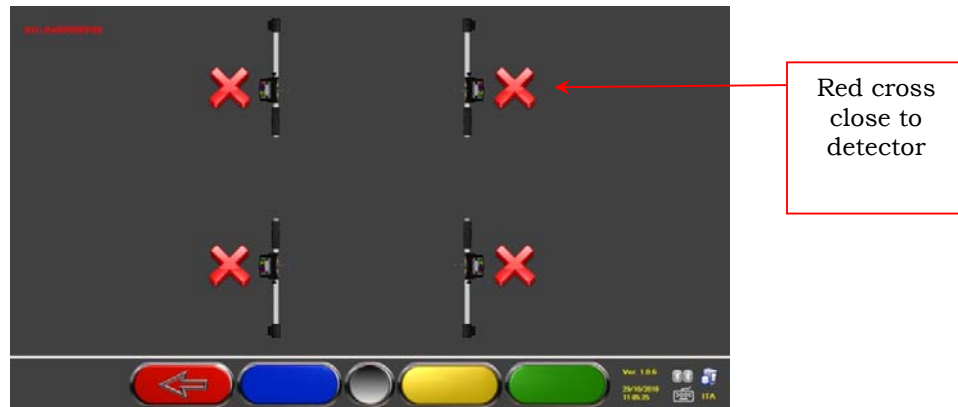

Figure 70

This means that there is a transmission/reception failure due to one or several of the following problems:

- Detectors infrared transceivers are not working
- There is a failure or a radio interference inside the transmission system,
- There is a hinder (ex. vehicle door open) between front and rear detectors.

Rear detectors do not directly communicate with cabin: their data are transmitted/received passing through front detectors so, if a front detector is not working properly, data could not be transmitted to the corresponding rear detector, even if this latter is working.

If the cause of failure is eliminated (ex. vehicle door is closed) error page will immediately disappear, and the measurement page will be displayed again. If the problem continues, check system hardware by switching machine off. Of course, it is not recommended to abruptly power cabin off; follow the correct switching off procedure:

- Press “Esc” on keyboard to go back to the introduction page (chap.8 on page19).
- Switch machine off following the correct procedure (see par.4.2 on page 13).

11.2 Angle Measurement Horizontal Error

The following screens may be displayed during infrared data measurement:

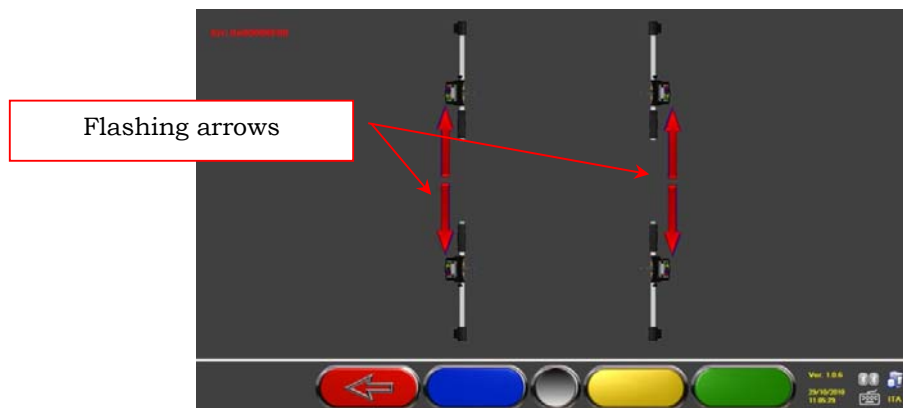

Figure 71

This error page indicates that one or more horizontal infrared measurements cannot be carried out.

There may be several causes:

- One or more CCD sensors (digital infrared transducer for horizontal angle measurement) are not working.
- One or more infrared emitters for horizontal angle measurement (I.R. LED) are not working.
- There is a hinder (ex. vehicle door open) between front and rear detectors.

If the cause of failure is eliminated (ex. vehicle door is closed) error page will immediately disappear, and the measurement page will be displayed again. If the problem continues, check system hardware by switching machine off. Of course, it is not recommended to abruptly power cabin off; follow the correct switching off procedure:

- Press “Esc” on keyboard to go back to the introduction page (see chap. 8 on page 19).
- Switch machine off following the correct procedure (see par.4.2 on page 13).

12 TROUBLES

Some of the most common problems that could arise on wheel aligners are listed here below. Atlas declines all liability for injury or damage to persons, animals and properties caused by the intervention of unauthorised personnel, and by the use of non-original spare parts.

Before doing any operation on the system, always disconnect the power supply.

In case of doubt, do not interpret, but contact Atlas technical assistance in order to obtain instructions suitable for performing operations in total safety.

TROUBLE	CAUSE	REMEDY
NO OPERATION	- No mains voltage - Interrupted protection fuses	- Check mains voltage - Check protection fuses
Monitor does not work	- No supply voltage - No video signal	- Check power cable connection - Check video signal cable connection between PC and monitor
PC cannot be switched on	- No supply voltage	- Check PC ON/OFF switch - Check power cable connection
Printer does not work (see also printer user's manual)	- No supply voltage - No signal	- Check ON/OFF voltage - Check power cable connection - Check printer signal cable connection with PC

13 MAINTENANCE

WARNING! Before doing any maintenance job, the machine will have to be disconnected from the power mains.

To clean plastic panels or surfaces use alcohol (AVOID USING LIQUIDS CONTAINING SOLVENTS).

DISPLAY shall be cleaned with a dry cloth; if very dirty, clean it with a moist cloth, then dry it.

Do not spray the alcohol directly on the control panel and do not clean using strong jets of compressed air.

Keep optical unit methacrylate filters clean using a slightly moist cloth, do not use solvents; Printer cleaning, cartridge replacement and any other maintenance operation on printer are described in the manual supplied with the printer itself. Always refer to this manual before carrying out any maintenance operation on printer.

14 STORAGE AND SCRAPPING

Storage - If the machine has to be stored for a long period of time, disconnect all supply lines and protect the display screen, which could be damaged by excessive dust. Grease any parts liable to be damaged by dryness.

Scrapping - If the machine is to be no longer used, it must be made inoperative: All those parts that could represent a potential hazard risk must be correctly disposed of. Dispose of parts according to category. Scrap as iron scrap through authorised channels. Parts considered as special waste must be removed and split up according to type and then disposed of through authorised channels according to applicable regulations.

15 MACHINE IDENTIFICATION DATA

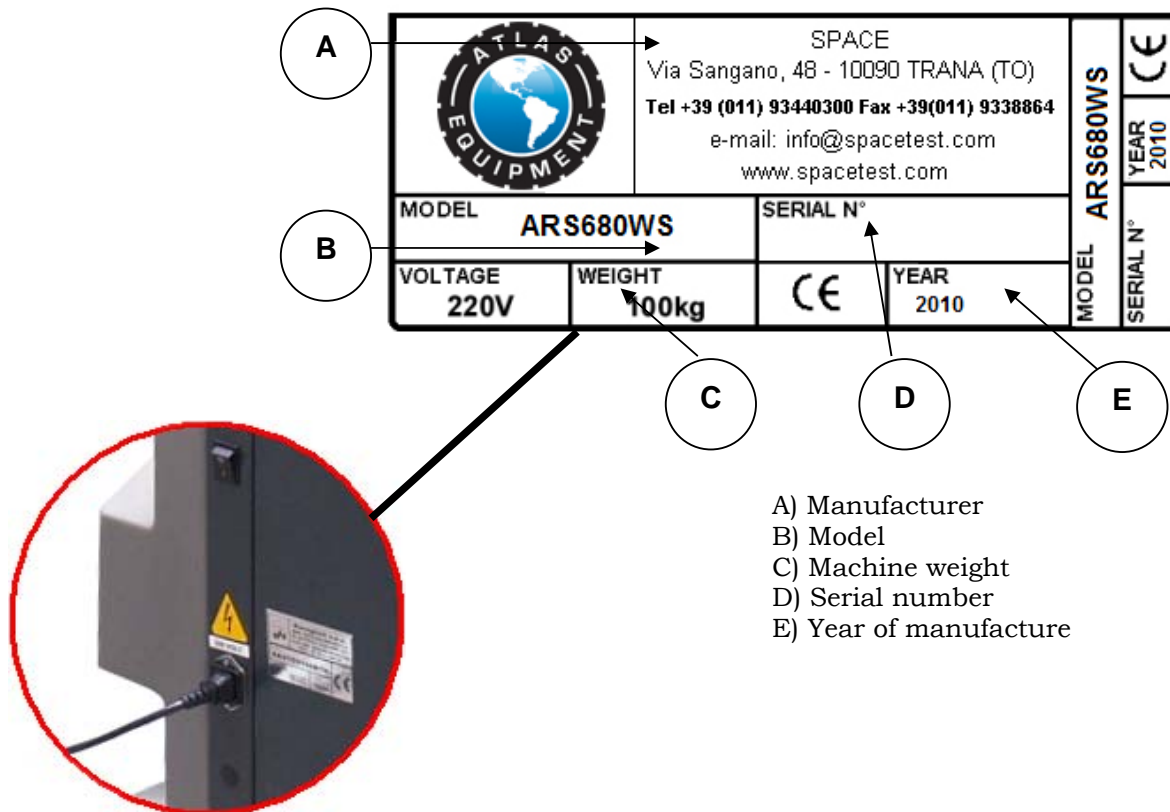

		SPACE Via Sangano, 48 - 10090 TRANA (TO) Tel +39 (011) 93440300 Fax +39(011) 9338864 e-mail: info@spacetest.com www.spacetest.com		MODEL ARS680WS	YEAR 2010	CE
MODEL ARS680WS		SERIAL N°				
VOLTAGE 220V	WEIGHT 100kg	CE	YEAR 2010	MODEL ARS680WS	SERIAL N°	

A) Manufacturer
B) Model
C) Machine weight
D) Serial number
E) Year of manufacture

WARNING: It is strictly forbidden to tamper with, notch, somehow alter or even remove machine identification plate; do not cover it with temporary panels, etc... as it shall always be clearly visible.

Said plate must always be kept clean.

CAUTION: Should the plate be accidentally damaged (removed from the machine damaged or even partially illegible) inform immediately the manufacturer.