

# USE AND MAINTENANCE MANUAL

## PRESS ARM HELP

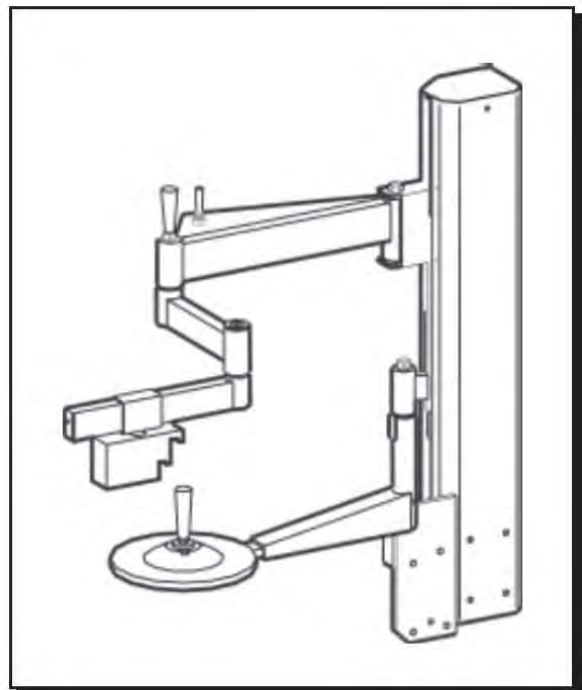
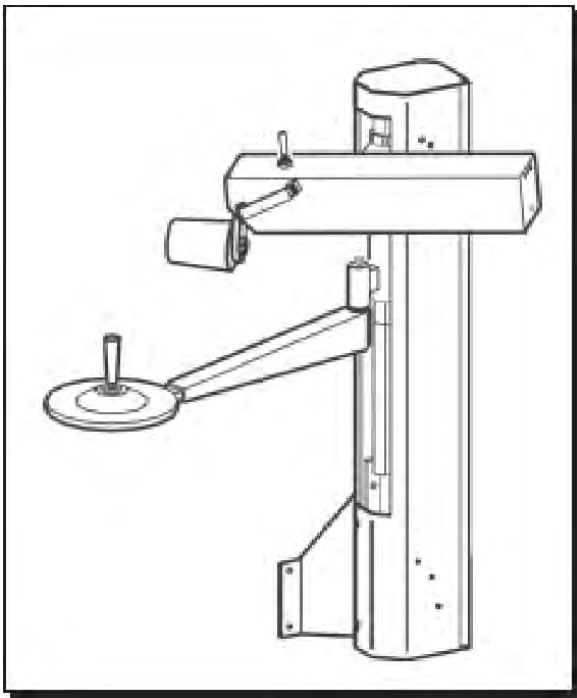

## CONTENTS

<b>1</b>	<b>INTRODUCTION</b>	<b>3</b>
<b>2</b>	<b>PRODUCT DESCRIPTION</b>	<b>4</b>
<b>3</b>	<b>GENERAL INFORMATION</b>	<b>5</b>
<b>4</b>	<b>INSTALLATION</b>	<b>6</b>
<b>5</b>	<b>USE</b>	<b>10</b>
<b>6</b>	<b>MAINTENANCE</b>	<b>12</b>

## CHAPTER 1 - INTRODUCTION

Thank you for purchasing a product from the line of accessories. The machine has been manufactured in accordance with the very best quality principles. Follow the simple instructions provided in this manual to ensure the correct operation and long life of the machine. Read the entire manual thoroughly and make sure you understand it.

### IDENTIFICATION DATA

A complete description of the “Model” and the “Serial number” will make it easier for our technical assistance to provide service and will facilitate delivery of any required spare parts. For clarity and convenience, we have inserted the data of your tyre changer in the box below. If there is any discrepancy between the data provided in this manual and that shown on the plate fixed to the machine, the latter should be taken as correct.

This manual is an integral part of the product. Before using the tyre changer, read carefully the warnings and instructions contained in this manual since they provide important information on operating safety and maintenance.



**Keep this manual for future reference.**

## CHAPTER 2 - PRODUCT DESCRIPTION

- 1) Arm 1
- 2) Arm 2
- 3) Arm 3
- 4) Bead pressing too
- 5) Arm with bead lifting disk
- 6) Lifting/lowering control
- 7) Lifting/lowering control
- 8) Operating arm with roller tool
- 9) Arm with bead lifting disk

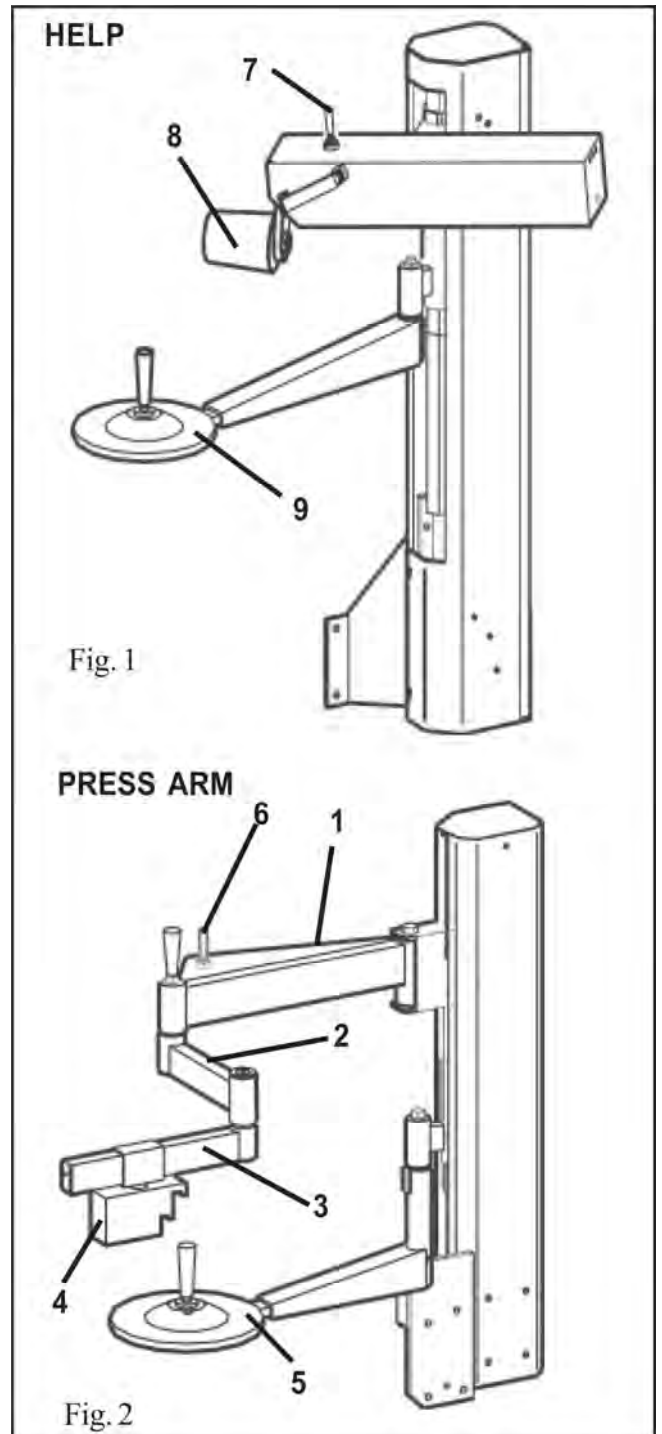

## CHAPTER 3 – GENERAL INFORMATION

### 3.1 INTENDED USE

These accessories have been designed and manufactured exclusively for being installed on a tire changer in order to facilitate removing and mounting of tires from/onto the rim.



In particular the manufacturer cannot be held responsible for any damage caused through the use for purposes other than those specified in this manual, and therefore inappropriate, incorrect and unreasonable.

### 3.2 GENERAL SAFETY RULES

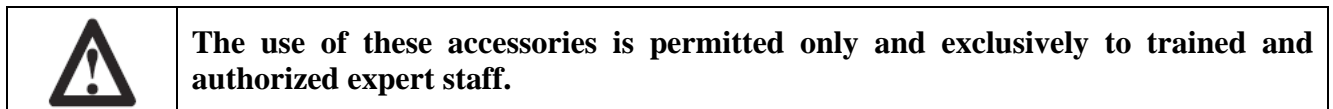

Any tampering or modification to the equipment carried out without the manufacturer's prior authorization will free him from all responsibility for damage caused directly or indirectly by the above actions.

Removing or tampering with safety devices immediately invalidates the warranty.

### 3.3 TRANSPORTATION

The accessories must be transported in their original package and kept in the position shown on the package itself.

The packaged accessories may be moved by means of a forklift truck of suitable capacity.

### 3.3 UNPACKING

Once the packing material has been removed, check the machine visually for any signs of damage. Keep the packing materials out of the reach of cylinder as they can be a source of danger.

Keep the packing for possible future transport.

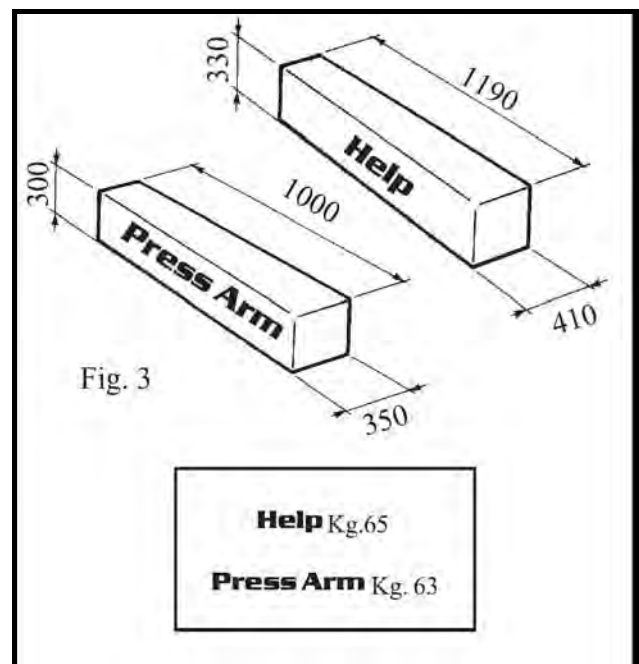

## CHAPTER 4 – INSTALLATION

The accessories need to be connected to a compressed air system with values between 8 – 10bar.

### 4.1 INSTALLATION ON TIRE CHANGER

#### 4.1.1 MOUNTING HELP

- Unscrew the lubricator support (A);
- Remove the side cover from the machine;
- Set the support plates (D) and fix them by means of nuts M10 (F);
- Mount HEP onto the supports and fix it by means of nuts M10 (E);
- Screw the lubricator (if any) in the holes present on the HELP body;
- Fix the lubricator to its support (if any) or directly to the HEPL body.

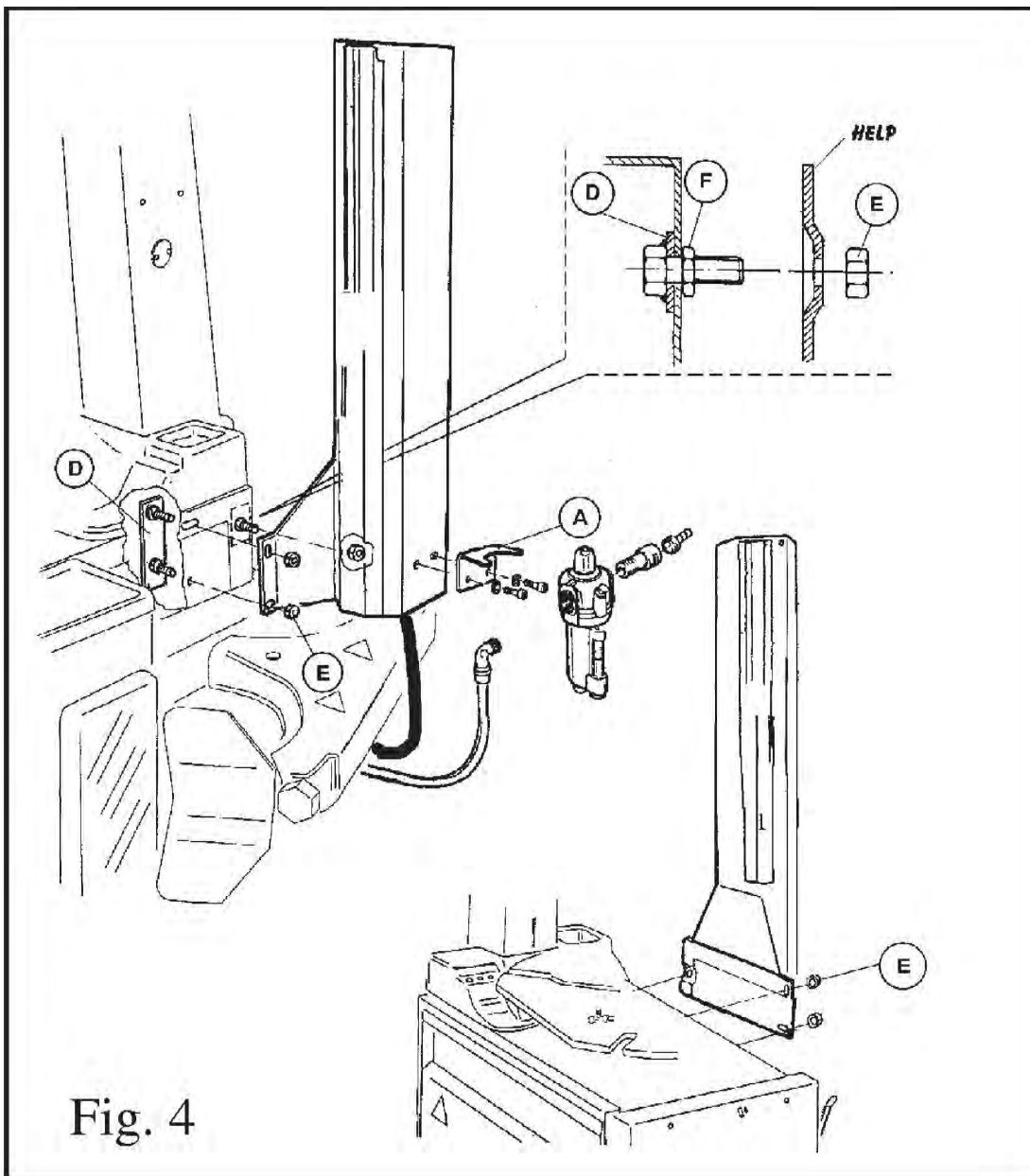

#### 4.1.2 MOUNTING PRESS ARM

- Mount the support (G) onto the frame by means of 2 screws M10X25 and relevant nuts; (fig.5)
- Fix the column (L) to the back part of the frame by means of 3 screws M10X25 and relevant nuts; (fig. 6)
- Connect PRESS ARM base (H) to the support (G) and to the column (L) as indicated on the drawing. (fig. 7)

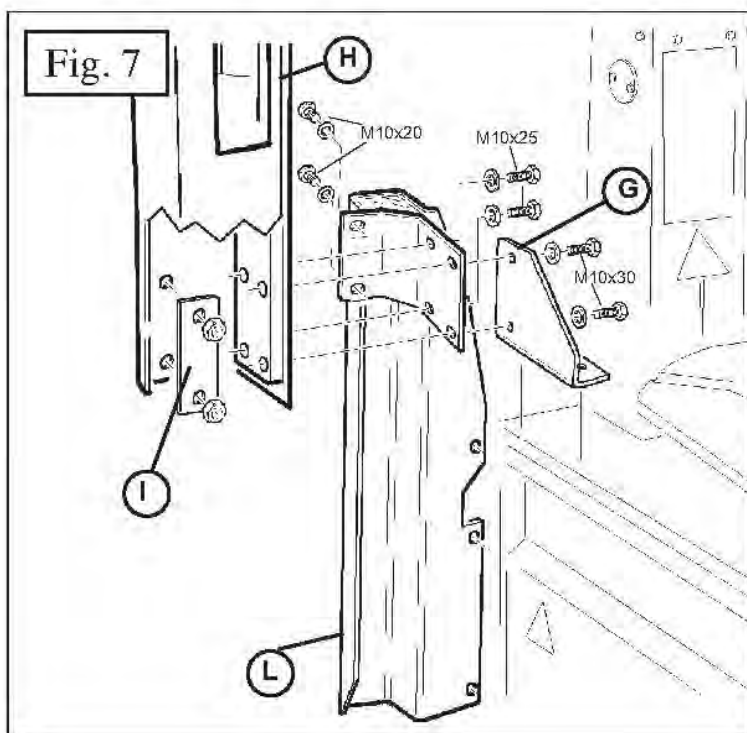
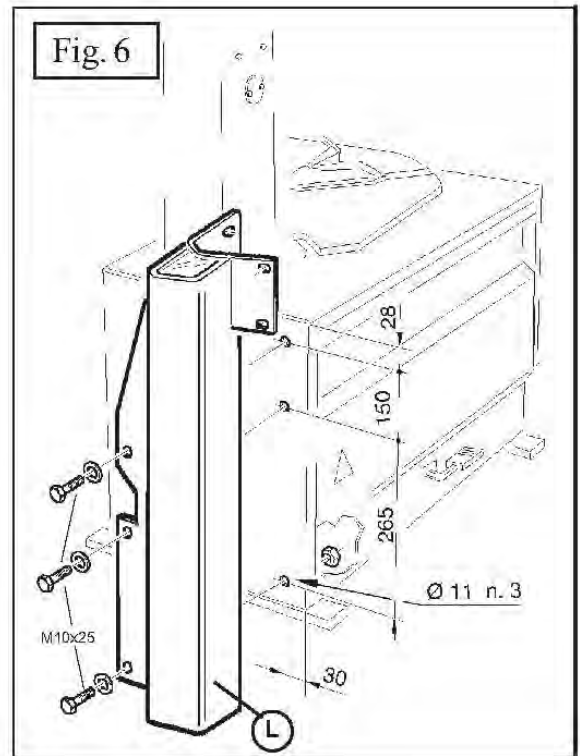
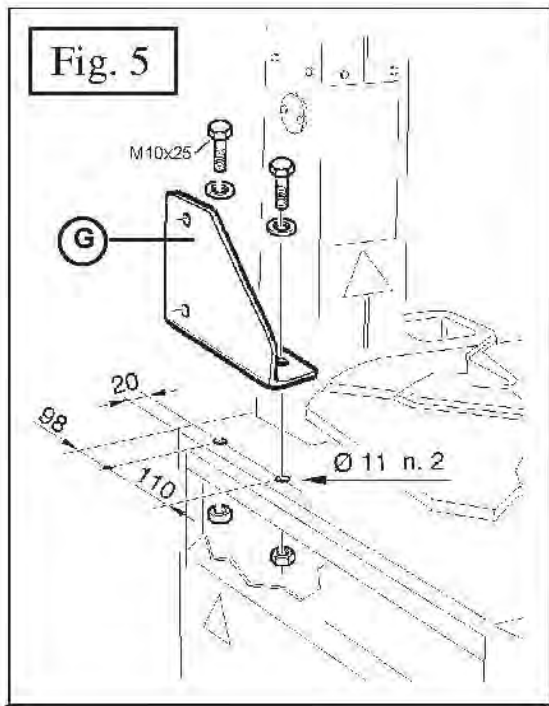

## 4.2 COMPONENTS ASSEMBLY

### 4.2.1 HELP COMPONENTS ASSEMBLY

- Let the arm with bead lifting disk (9) slide into its housing and tighten screw (P) with relevant washers; (fig. 11)
- Remove screw (Q) and washer and loosen screws (R); (fig 11)
- Lift the operating arm fairing (8) as high as necessary and inset the hexagon in the proper seat; (fig. 11)
- Reposition the fairing and fix it by tightening screws (Q) and (R); (fig. 11)
- Connect the pneumatic hoses according to the plan. (fig. 12).

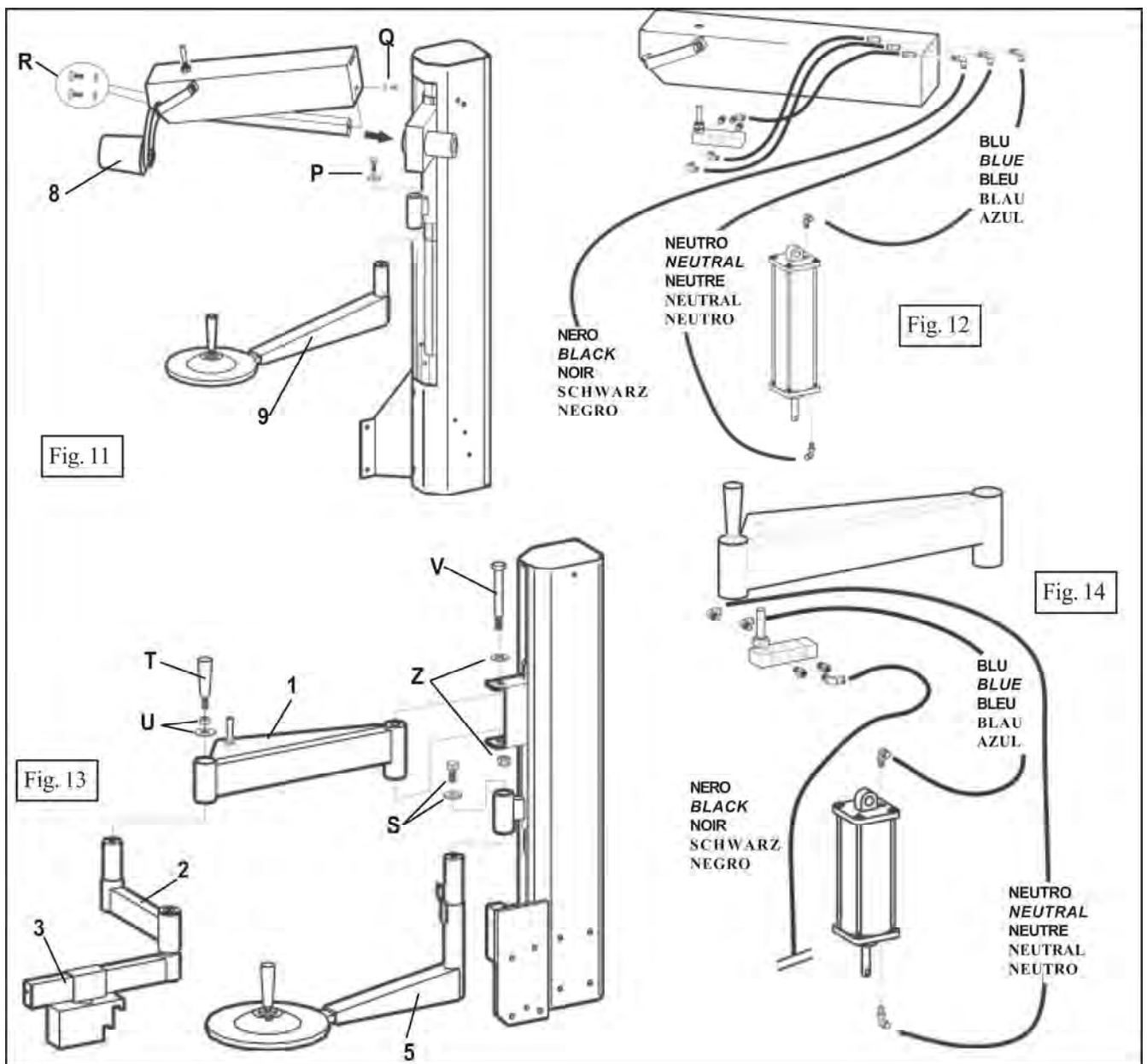



## 4.2.2 PRESS ARM COMPONENTS ASSEMBLY

- Let the arm with bead lifting disk (5) slide into its housing and tighten screw (S) with relevant washers; (fig. 13)
- Connect the pneumatic hoses of control valve according to the plan; (fig. 14)
- Mount the arm 1 at the base, setting it into the relevant housing. Lock the whole unit by means of screw (V), relevant washers and the nut (Z); (fig 13)
- Connect arms 2-3 (already joined to each other) to the arm 1 inserting them in relevant seats; (fig. 13)
- Lock the whole unit by screwing in handle (T), counter-nut (U) and relevant washer as shown in the figure 13.

## 4.3 PNEUMATIC CONNECTION TO TIRE CHANGER

### 4.3.1 PRESS ARM PNEUMATIC CONNECTION

- Set the pipe (K) into the hole on the backside of the machine;
- Cut the hose (J) coming from the lubricator and directed to pedals. Connect the two hose ends to the T-union delivered;
- Connect the feeding pipe (K) of PRESS ARM with T-union through the proper union delivered.

### 4.3.2 HELP PNEUMATIC CONNECTION

- Set the pipe (w) into the hole on the right side of the machine, under the bead-breaker;
- Cut the hose (J) coming from the lubricator and directed to pedals. Connect the two hose ends to the T-union delivered;
- Connect the feeding pipe (W) of HELP with T-union through the proper union delivered.

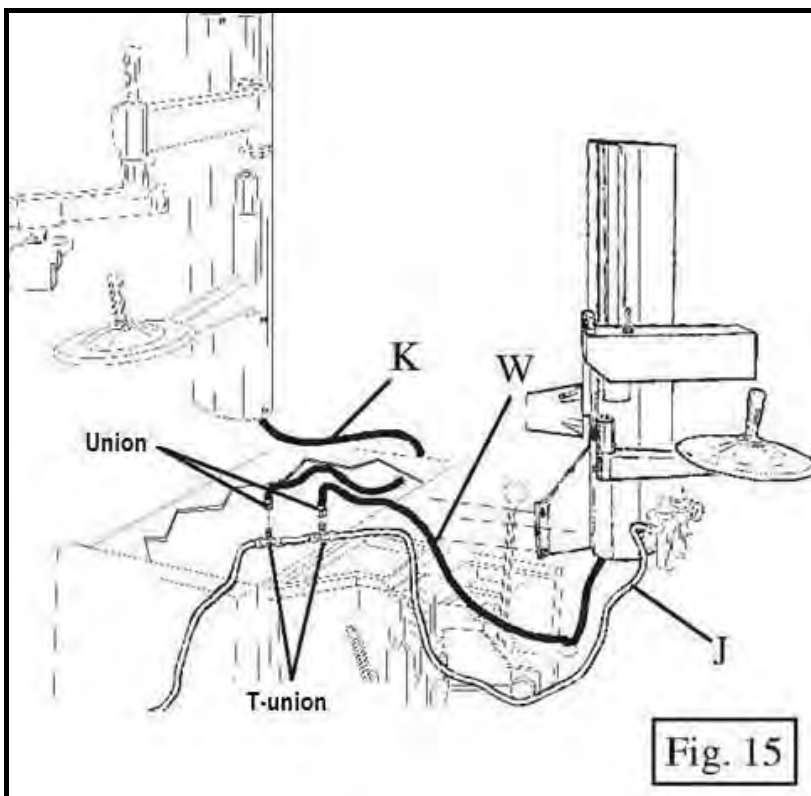

## CHAPTER 5 – USE

### 5.2 REMOVAL OF EXTRALOW PROFILED TIRES OR RACING TIRES

#### 5.2.1 UPPER BEAD

- Lock the rim onto the turntable as shown in tire-changer's installation, use and maintenance guide;
- In case of difficulty, use the bead-pusher (4) of PRESS ARM for keeping the rim pressed onto the turntable clamps and facilitate its locking (fig. 16);
- Position the mounting head as indicated by standard proceeding for tire removal inside the installation, use and maintenance guide;
- Position (fig. 17) HELP roller (8) at the right side of the mounting head (X) and PRESS ARM bead-pusher (4) at the opposite side, so that they press slightly the tire downwards, in order to facilitate introduction of the bead-lifting lever (Y);
- Release HELP and lower the lever to bring the tire bead onto the mounting head;
- Release PRESS ARM and follow removing standard proceedings;
- By means of HELP bead-lifting disk, press the lower tire rim in order to avoid its re-beading (fig. 18).

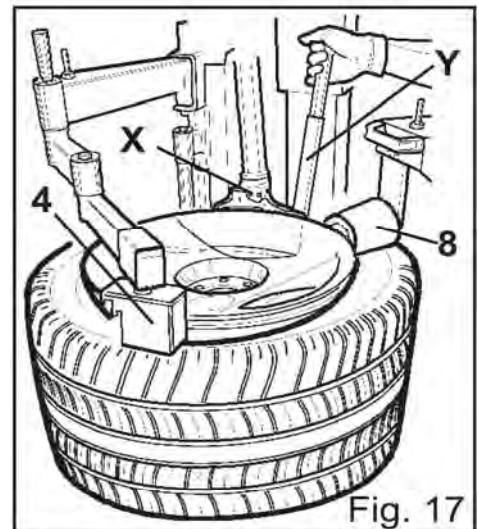
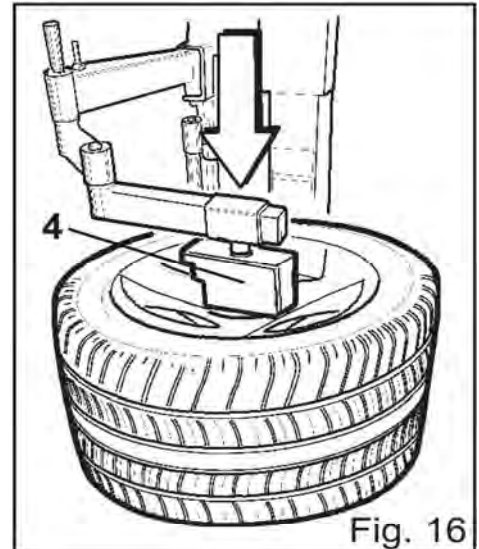

#### 5.2.2 LOWER BEAD

- Follow standard proceedings for tire final removal and use HELP and PRESS ARM bead-lifting disks for keeping the tire at the same level of rim's groove. In this way, the introduction of bead-lifting lever will be facilitated (fig. 19).

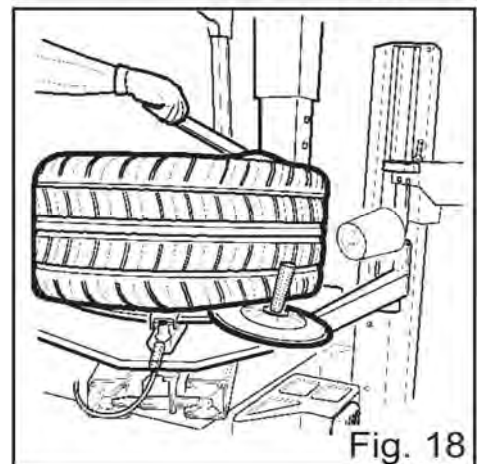
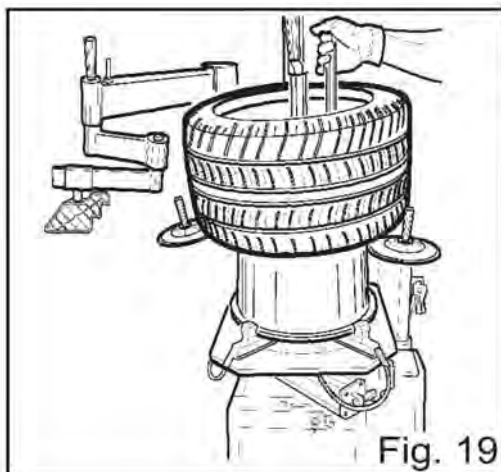

### 5.3 MOUNTING EXTRALOW PROFILED TIRES OR RACING TIRES

#### 5.3.1 LOWER BEAD

- Follow standard proceedings described in the installation, use and maintenance guide of tire changer.

#### 5.3.2 UPPER BEAD

- Position the tire as described by standard proceedings inside the installation, use and maintenance guide of tire changer;
- Position the HELP roller (8) and the PRESS ARM bead-pusher (4) at the right side of the mounting head (X) in a way that tire upper bead stays at the same level of rim's groove (fig. 20),
- Let the turntable turn until the tire is completely mounted (fig. 21);
- Release HELP and PRESS ARM.

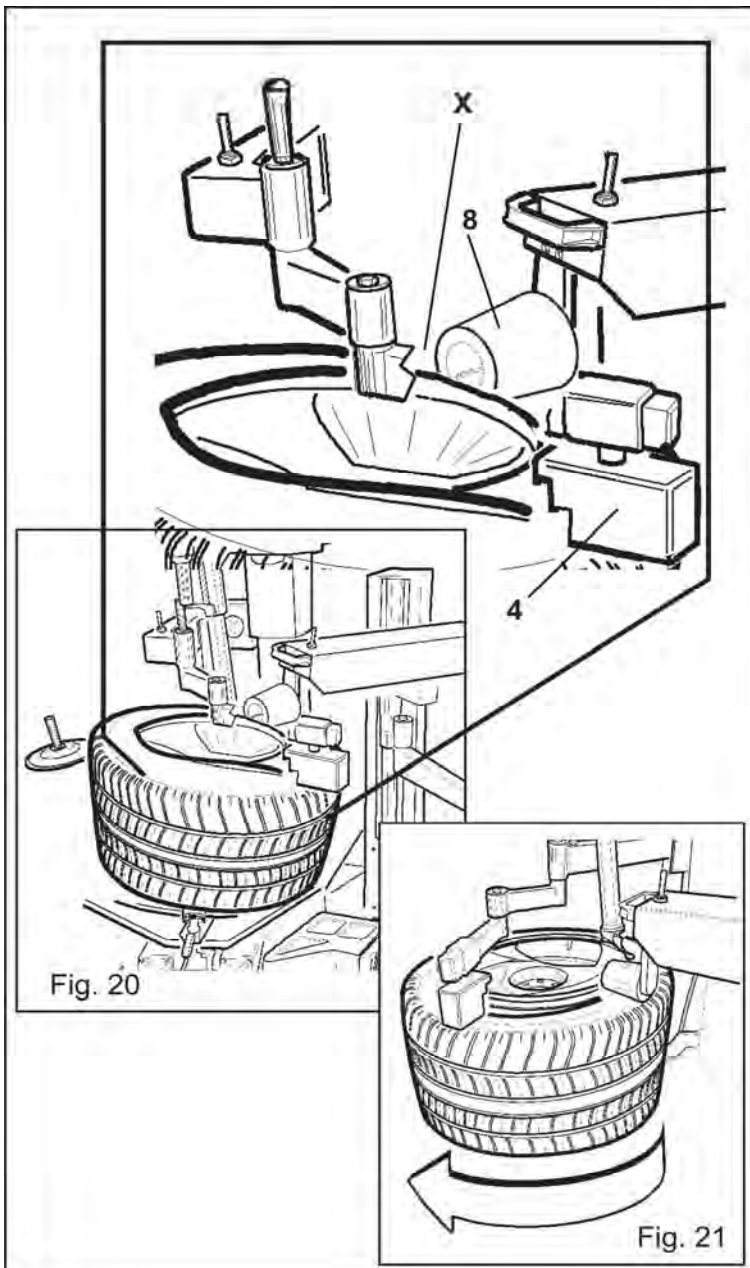

## CHAPTER 6 – MAINTENANCE



**Unauthorized person is forbidden to carry out maintenance work.**

- Regular maintenance as described in the manual is essential for correct operation and long lifetime of the tire changer.
- If maintenance is not carried out regularly, the operation and reliability of the machine may be compromised, thus placing the operator and anyone else in the vicinity at risk.



**Before carrying out any maintenance work, disconnect the electric and pneumatic supplies. Moreover, it is necessary to break the bead without load 3-4 times in order to let the air in pressure go out of the circuit.**

- Defective parts must be replaced exclusively by expert personnel using the manufacturer's parts.
- Removing or tampering with safety devices (pressure limiting and regulating valves) is extremely forbidden.



**In particular the Manufacturer shall not be held responsible for complaints deriving from the use of spare parts made by other manufacturers or for damage caused by tampering or removal of safety systems.**

- Clean and grease weekly the sliding guides.
- For the rest, make reference to the installation, use and maintenance guide of tire changer, on which HELP and PRESS ARM are mounted.



ED. 07/2008

**PART CATALOGUE**  
**RIGHT HELPER**

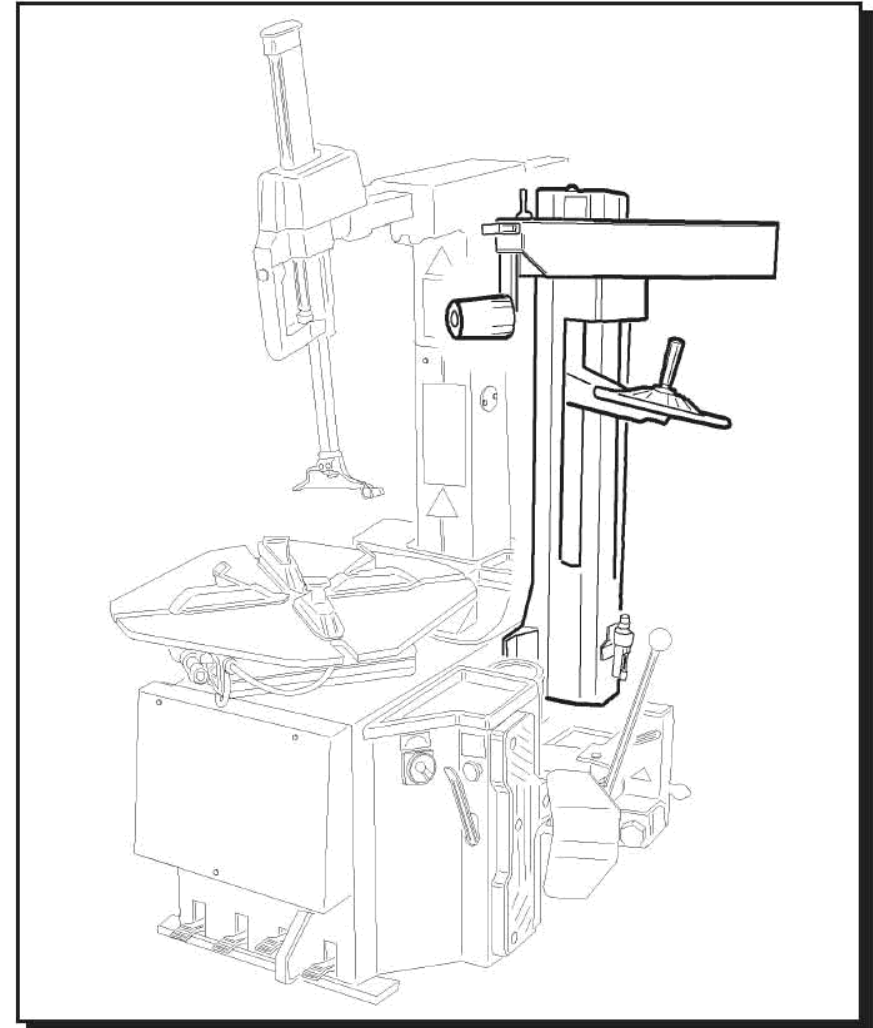

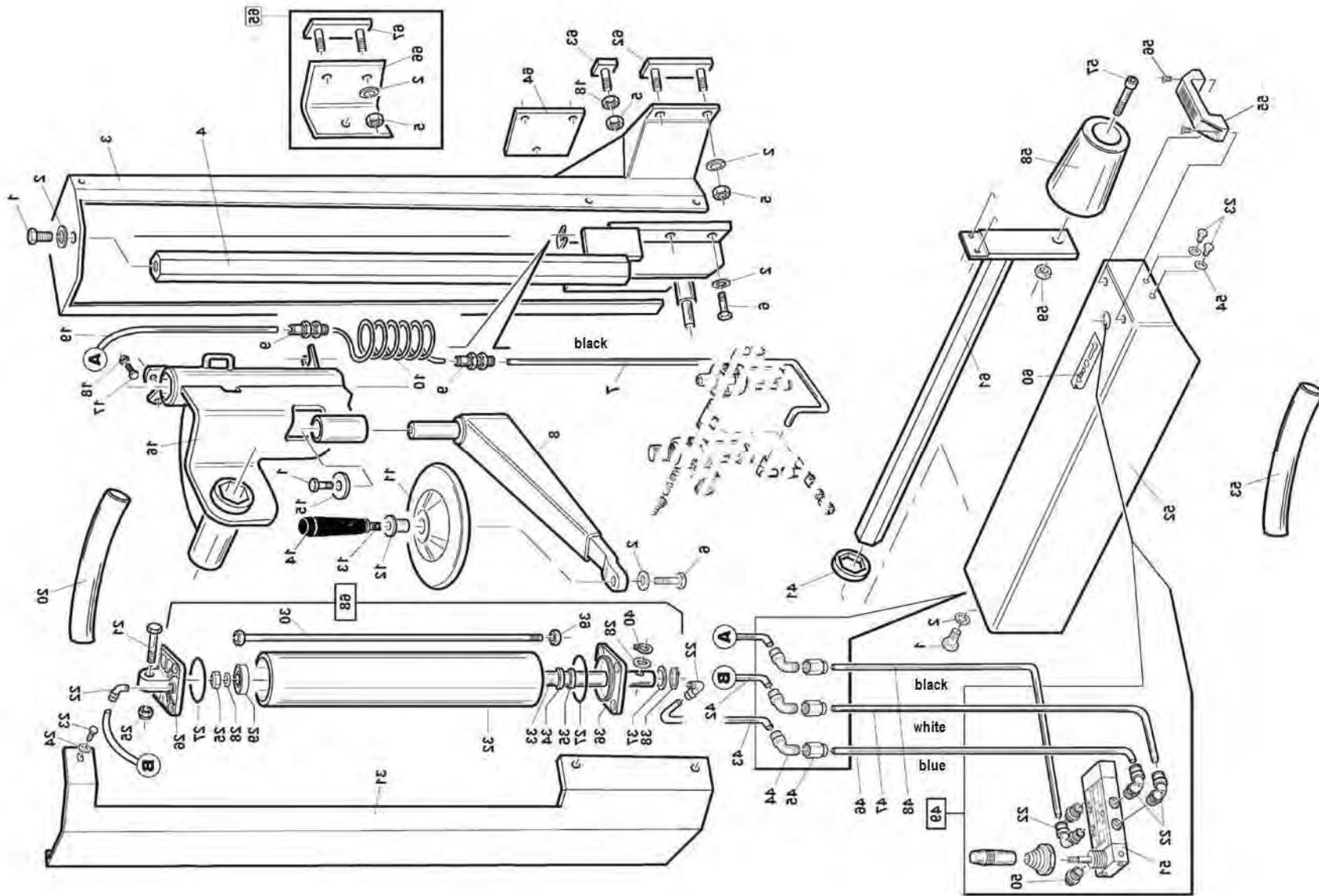

ITEM	CODE	REF. NO	DESCRIPTION	QTY	REMARK
1	4399966	GB/T5783	Screw M10X20 8.8	3	
2	4399378	GB/T97.1	Washer 10	9	
3	2408816	YCH-2408816	Help base	1	
4	2408815	YCH-2408815	Vertical arm	1	
5	4399969	GB/T6182	Self-locking nut M10	3	
6	4399786	GB/T5783	Screw M10X30 8.8	4	
7	3014450		Rilsan hose 6X4 L=1450 black	1	
8	2407546	YCH-2407546	Bead breaking disk arm	1	
9	4195524		Union D.6	2	
10	3014449		Spiral rilsan hose 6X4 D.40	1	
11	3006886	YCH-3006886	Bead breaking disk	1	
12	3006862	YCH-3006862	Disk pin	1	
13		GB/T79	Screw M10X30	1	
14	2012683	YCH-2012683	Handle	1	
15	3002311	YCH-3002311	Washer	1	
16	2415666	YCH-2415666	Help slide	1	
17	4398901	GB/T5783	Screw M10X25	1	
18		GB/T6172	Nut M10	2	
19	3014451		Rilsan hose 6X4 L=1100 black	1	
20			PVC hose D.20XD.18 L=860	1	
21		GB/T70.1	Screw M10X50	1	
22	4198618		90° union 1/8" D.6	5	
23	4398723	GB/T5783	Screw M6X12 8.8	9	
24	4399999	GB/T96	Washer D.6	7	

25	4399865	GB/T6182	Self-locking nut M12	2
26	3015023	YC1-3015023	Back flange	1
27	4298822	GB/T3452.1	O-ring 75X3.55	2
28		GB/T97.1	Washer D.12	3
29	4198856	YC1-4198856	Piston	1
30	3008334	YCH-3008334	Stud bolt M8X1.25X517	4
31	3008817	YCH-3008817	Help cover	1
32	3008333	YCH-3008333	Cylinder liner	1
33	3006649	YCH-3006649	Piston rod	1
34	4299168	GB/T3452.1	O-ring 20X2.75	1
35	3199601		Scraper ring 20X30X7	1
36	3015024	YC1-3015024	Front flange	1
37	4398146	YC1-4398146	Shim 24X30X0.5	1
38	3199599	GB/T893.1	Seeger D.30	1
39	4397678	GB/T6177	Flange nut M8	4
40	4399864	GB/T894.1	Seeger D.12	1
41	3002601	YC1-3002601	Shock absorber	1
42	3014455		Rilsan hose 6X4 L=1100 white	1
43	3014456		Rilsan hose 6X4 L=1500 blue	1
44	4298618		Union 1/8" D.6	3
45	4198172		Union 1/8" D.6	3
46	3014454		Rilsan hose 6X4 L=540 blue	1
47	3014453		Rilsan hose 6X4 L=540 white	1
48	3000143		Rilsan hose 6X4 L=540 black	1
49	2006996	YCP-2006996	Valve unit	1



50	4199610		Silencer 1/8"	2
51	4198285		3-positions/5-ways valve	1
52	2406853	YCH-2406853	Horizontal arm cover	1
53			PVC tube D.20XD.18 L=400	1
54	4399998	GB/T97.1	Washer D.6	2
55	4297851	YCH-4297851	Handle	1
56	4398672	GB/T70.3	Screw M6X16	2
57	4397454	GB/T70.1	Screw M20X90	1
58	3008433	YCH-3008433	Bead breaking roller	1
59	4399810	GB/T6172	Nut M20	1
60	3008944		Decal	1
61	2407115	YCH-2407115	Horizontal arm	1
62	6608782	YCH-6608782	Fastening U-bolt	1
63	3008784	YCH-3008784	Anti-rotation screw	1
64	6609675	YCH-6609675	Fixing plate	1
65	2010310	YCH-2010310	Help arm installation kit	1
66	3010304	YCH-3010304	Support	1
67	2110301	YCH-2110301	Fastening U-bolt	1
68	2008332	YCH-2008332	Help cylinder unit	1