

ATLAS **PLATINUM**

PWB 50

Use and maintenance instruction manual



INDEX

Introduction	5
1.0 Foreword	6
1.1 General	6
1.2 Manual purpose	6
1.3 Where And How To Keep The Manual	7
1.4 Manual Upgrades	7
1.5 Collaboration With Users	7
1.6 Manufacturer's Responsibility And Warranty	7
1.6.1 Terms Of Warranty	8
1.7 Technical Assistance Service	8
1.8 Copyright	8
2.0 Safety rules	9
2.1 General notes	9
2.2 Symbols	9
2.3 Definitions of "operator" and "specialised technician"	9
2.4 Personal protection devices (ppd)	10
2.5 Protection devices to wear	10
2.6 General warnings	11
2.7 Emergencies	11
2.7.1 First aid	11
2.7.2 Fire-fighting measures	12
2.7.3 Airborne noise emission	12
2.7.4 Operator working position	12
3.0 Unpacking and positioning	12
3.1 Visual inspection	12
3.2 Checking the machine and equipment supplied	12
3.3 Unpacking	13
3.4 Packing list	13
3.5 Storage	13
3.6 Handling	14
3.7 Removing the pallet	14
3.8 Positioning	15
3.8.1 Warnings for positioning	15
4.0 Installation	16
4.1 Cleaning	16
4.2 Ambient characteristics	16
4.3 Fitting the adapters	16
4.4 Electrical connection	17
4.4.1 Safety rules	17
4.4.2 Pneumatic connection	17
5.0 Residual risks	18
6.0 Machine Description	19
6.1 Purpose	19
6.2 Technical Specifications	20
6.3 Dimensions	20

7.0 Starting	20
8.0 Control Panel	23
9.0 Use Of The Wheel Balancer	24
9.1 Presetting Of Wheel Dimensions	24
9.1.1 Et (This Function Is Available Only In The Absence Of The La Sonar)	25
9.1.2 Modifying Set Dimensions	26
9.1.3 Automatic Width (Option)	26
9.2 Measurement Result	27
9.3 Static Unbalance	27
9.4 Exact Positioning Of The Adhesive Weight By Means Of The Gauge With Clips	27
9.5 Split Function (Unbalance Resolution)	28
9.6 Double Operator Program	29
9.7 Automatic Minimization Of Static Unbalance	30
10.0 Setup	31
10.1 Menu	31
10.2 Unbalance Optimisation	32
10.3 Opposite Position	33
10.4 Self-Diagnostics	33
10.5 Calibration	34
10.6 Automatic Gauges Calibration	35
10.6.1 Rim Distance Gauge	35
10.6.2 Diameter Gauge	36
10.6.3 Width Sonar (Option)	37
11.0 Diagnostics	38
11.1 Inconsistent Unbalance Readings	38
11.2 Alarm Signal	38
12.0 Maintenance	41
12.1 General	41
12.1.1 Introductory Notes	41
12.1.2 Safety Rules	41
12.1.3 Replacing Fuses	41
13.0 Disposal	42
13.1 Disposing Of The Balancer	42
13.2 Disposing Of Electronics Components	42
14.0 Spare Parts	42
14.1 Identification And Ordering Method	42
15.0 Attached Documentation	42

INTRODUCTION

We thank you for purchasing one product included in our range of wheel-balancers.

The machine is manufactured exploiting the best of quality principles.

To ensure correct operation and long life of the machine, all you need to do is follow these simple instructions, which shall be read and fully understood in every single part.

DETAILS OF THE WHEEL-BALANCERS

When contacting our Service Department or when requesting spare parts, please provide a complete description of the Model of the tyre changer and its Serial Number.

For the sake of simplicity and commodity, the details of your tyre changer are written in the space below.

If the details given in this manual do not match those written on the nameplate of your tyre changer, those written on the nameplate are the ones to be considered valid.

DETAILS OF THE MANUFACTURER:

- Consult the Declaration of conformity and the data nameplate (fitted on the machine)

NAMEPLATE DATA

FAC-SIMILE			
Type: PWB50	Nr.		
Ph 1	Volt 230	Hz 50/60	Kw 0.65
A:	T° [C] 0/+45	Year 2018	
Net Weight Kg: 93			

This manual is an integral part of the machine.

Before you use the tyre changer, read the warnings and instructions given in this manual carefully and thoroughly, because they provide important information on safe use and maintenance.



Keep this manual with care for future consultation

NOTE: some of the illustrations shown in this manual have been taken from pictures of prototypes. Consequently, some parts or components of the machines of standard production may differ from what is illustrated.

1.0 FOREWORD



WARNING
THIS MANUAL IS AN INTEGRAL PART OF THE INSTALLATION MANUAL WHICH SHOULD BE CONSULTED CONCERNING STARTING AND USING THE MACHINE SAFELY. READ CAREFULLY BEFORE CONTINUING.

1.1 General

The machine has been constructed in conformity with the current EC Directives and the technical standards implementing the requirements, as stated in the declaration of conformity issued by the manufacturer and attached to the manual.

This publication, hereinafter simply referred to as '**manual**', contains all the information required to safely use and service the machine referred to in the Declaration of Conformity.

This appliance, hereinafter is generically referred to as '**machine**'.

The manual addresses operators instructed on the precautions to take in relation to the presence of electric current and moving devices.

This publication is intended for all 'users' who as far as within their competence need to and/or are obliged to give instructions to others or operate on the machine themselves.

These persons can be identified as follows:

- operators directly involved in transporting, storing, installing, using and servicing the machine from when it is put on the market until when it is scrapped;
- direct private users.

The original Italian text of this publication constitutes the only reference to resolve any interpretation controversies related to the translation into the European Community languages.

This publication forms an integral part of the machine and must therefore be kept for future reference until final dismantling and scrapping of the machine.

1.2 Purpose of the manual

This manual, and the installation manual, contains the instructions required to use the machine safely and carry out routine maintenance work.

Any calibrations, adjustments and extraordinary maintenance operations are not considered in this document as they may only be performed by the service engineer who must work on the machine according to the technical and rated characteristics for which it was built.

Though it is fundamental to read this manual, it cannot replace skilled technical staff who must be adequately trained beforehand.

The foreseen use and configurations of the machine are the only ones allowed by the manufacturer; do not attempt to use the machine in a different way.

Any other use or configuration must be agreed in advance with the manufacturer in writing and in this case an annex will be attached to this manual.

For use, the user must also comply with the specific workplace legislation in force in the country where the machine is installed.

The manual also refers to laws, directives, etc., that the user must know and consult in order to accomplish the goals that the manual sets out to achieve.

1.3 Where and how to keep the manual

This manual (and relative attachments) must be kept in a safe and dry place and must always be available for consultation.

Make a copy and keep it in the archive.

When exchanging information with the manufacturer or the technical assistance staff authorised by the former, quote the rating plate information and the serial number of the machine.

This manual must be kept for the entire lifetime of the machine, and if necessary (e.g.: damage making all or some of it illegible, etc.) the user must request another copy exclusively from the manufacturer, quoting the publication code indicated on the cover.

1.4 Manual upgrades

This manual is an integral part of the machine and reflects the state of the art at the moment it was put on the market. The publication complies with the directives in force on that date; the manual cannot be considered inadequate as a result of regulatory updates or modifications to the machine.

Any manual upgrades that the manufacturer may see fit to send to users will become an integral part of the manual and must be kept together with it.

1.5 Collaboration with users

The manufacturer will be pleased to provide its customers with any further information they may require and will consider proposals for improving this manual in order to more fully satisfy the requirements it was written for.

In case of transfer of ownership of the machine, which must always be accompanied by the use and maintenance manual, the original user must inform the manufacturer of the name and address of the new user in order to allow it to send the new user any communications and/or updates deemed to be indispensable.

This publication is the property of the Manufacturer and may not be fully or partly reproduced without prior written agreement.

1.6 Manufacturer's responsibility and warranty

In order to make use of the manufacturer's warranty, the user must scrupulously observe the precautions contained in the manual, in particular he must:

- never exceed the limits of use of the machine;
- always constantly and carefully clean and service the machine;
- have the machine used by people of proven capacity and attitude, adequately trained for the purpose.

The manufacturer declines all direct and indirect liability caused by:

- use of the machine in a different way from that indicated in this manual
- use of the machine by people who have not read and fully understood the contents of this manual;
- use in breach of specific regulations in force in the country of installation;
- modifications made to the machine, software and operating logic, unless authorised by the manufacturer in writing;
- unauthorised repairs;
- exceptional events.

Transfer of the machine to a third party must also include this manual; failure to include the manual automatically invalidates all the rights of the purchaser, including the terms of warranty, where applicable.

If the machine is transferred to a third party in a country with a different language from the one written in this manual, the original user shall provide a faithful translation of this manual in the language of country in which the machine will operate.

1.6.1 Terms of warranty

The Manufacturer guarantees the machines it manufactures against all manufacturing or assembly faults for 12 (twelve) months from the date of collection or delivery.

The Manufacturer undertakes to replace or repair any part which it deems to be faulty free of charge at its factory, carriage paid.

If a Manufacturer's repairman (or a person authorised by the same) is required to work at the user's facilities, the relative travel expenses and board and lodging shall be charged to the user.

The free supply of parts under warranty is always subject to the faulty part being inspected by the manufacturer (or a person authorised by the same).

The warranty is not extended following repairs or other work done to the machine.

The warranty does not cover damage to the machine deriving from:

- transport;
- neglect;
- improper use and/or use not in compliance with the instructions in the operating manual
- incorrect electrical connections.

The warranty is invalidated in case of:

- repairs made by people who were not authorised by the manufacturer;
- modifications that were not authorised by the manufacturer;
- use of parts and/or equipment that were not supplied or approved by the manufacturer;
- removal or alteration of the machine identification plate.

1.7 Technical assistance service

For any technical service operation, contact the manufacturer directly or an authorised dealer always quoting the model, the version and the serial number of the machine.

1.8 Copyright

The information contained in this manual may not be disclosed to third parties. Partial or total duplication, unless authorised by the Manufacturer in writing, through photocopying, duplication or other systems, including electronic acquisition, is breach of copyright and can lead to prosecution.

2.0 SAFETY RULES

2.1 General notes



WARNING

Before performing any operation on the machine, carefully read through the entire manual, paying particular attention to this chapter.

The machine has been designed and constructed in observance of the CE requirements taking into account normal and reasonably foreseeable use.

The machine has been constructed for the application stated in the user manual attached hereto.

It is not permitted for any reason whatsoever to use the machine for purposes different from those for which it was designed nor to use it in ways different from those described in this manual.

The various operations must be performed according to the criterion and the chronology described in this manual.

2.2 Symbols

Throughout this manual dangerous operations are highlighted with graphic symbols to draw the reader's attention.



WARNING

This warning indicates possible occurrence of an event that may lead to serious injury or extensive damage to the machine if adequate precautionary countermeasures are not taken.

2.3 Definitions of “operator” and “specialised technician”

Any professional person who is to access the machine for operation and routine maintenance is defined as an “operator”.

This means persons who have knowledge of the operating and maintenance procedures of the machine and have the following qualifications:

1. training that authorises operation according to the safety standards in relation to the risks deriving from the presence of electrical power and moving devices and the risks related to manual load handling.
2. Trained to use the personal protection devices and basic first aid training.

The employer must assign a suitable person to operate the machine in accordance with the laws in force, assessing his or her psycho-physical health, personal education, training and experience, as well as knowledge of the standards, requirements and provisions for accident prevention.

In addition, the operator assigned based on the above must be specifically trained for use of the machine and any accessories.

Finally, the operator must read through this manual.

2.4 Personal protection devices (ppd)



WARNING

During machine installation and use it is strictly prohibited to operate without the protection devices described in this paragraph.

The persons that are to operate on and/or work in proximity of the machine may not wear clothes with wide sleeves, laces, belts, bracelets or anything else that may pose a potential risk. Long hair must be tied up to prevent any risk.

2.5 Protection devices to wear

The following protection devices must be worn.



Insulated safety shoes with rubber sole and reinforced tip

Use: always



Protective gloves

Use: always



Goggles

Use: always



Working clothes

Use: always

2.6 General warnings



CAUTION:

The machine generates, uses and may irradiate energy and radio frequency. If not installed and used in accordance with the instructions in this manual, it may cause interference with radio communications.

- The machine must be installed, maintained and used according to the instructions given in this manual and according to the procedures given from case to case.
- The employer must train the operators for safe installation, use and maintenance of the machine.
- Only specialised and specifically trained persons are to be allowed access to the machine for any extraordinary maintenance operation.
- Before operating on the electrical parts of the machine cut the power.
- For the duration of maintenance, “Work in progress” signs must be posted in the department in such a way that they are visible from all the access areas.
- Always operate with due caution and wear the personal protection devices (PPD).
- The machine (and any accessory devices) must always be connected to earth to discharge short-circuit currents and electrostatic voltages. The mains voltage must correspond to the value shown on the machine identification plate. It is inadvisable to use cable extensions/socket adaptors. When the machine is not used, disconnect it from the mains by pulling the plug from the socket.
- Before carrying out any operation stop the machine.
- In the event of fire, do not use water but only powder or carbon dioxide fire extinguishers.
- It is strictly prohibited to deposit combustible material in the vicinity of the machine.
- Do not deactivate the safety devices or ignore warnings and alarms, be they communicated by the software or by warning labels fixed on the installation. Should the plates, adhesive labels, decals or any other warning sign on the machine deteriorate they must be replaced.
- It is not permitted for any reason whatsoever to modify, tamper with or alter the machine structure, the devices fitted, the operating sequence, etc. without prior consultation with the manufacturer.
- All the routine and extraordinary maintenance operations must be recorded in the logbook noting down the date, time, type of operation, name of the operator and any other useful information.
- In the event of faults or malfunctioning, contact your local distributor or the manufacturer. All the repair operations must be performed by qualified technicians.
- It is strictly prohibited to clean the internal and external electrical parts of the wheel balancer with water.
- Exclusively use alcohol to clean the machine. Do not use any other chemical product. Do not under any circumstances blast with compressed air.
- Do not leave the machine exposed to the rain or the elements. The ambient storage and operating conditions must meet the requirements set out in the chapter INSTALLATION.
- In the event of failure, deformation or malfunctioning of the safety devices, immediately replace them; “Makeshift” repairs are strictly prohibited. Use only original spare parts for which the machine has been designed and constructed.
- The machine and the workplace must be kept perfectly clean.
- When the maintenance operations have been completed, before restoring the power supply, carefully check that you have not forgotten tools and/or other materials in the machine operating area. In any event, also during operation, no object may be placed on the protection shield.

2.7 Emergencies

2.7.1 First aid

For any first aid follow the corporate regulations and conventional procedures.

2.7.2 Fire-fighting measures

Do not use water to extinguish fires, but only powder or carbon dioxide extinguishers. Preferably use extinguishers filled with a special powder for metal fires.

2.7.3 Airborne noise emission

The machine noise, measured with the machine empty, is constantly contained at levels below 70 dB(A). During operation the machine noise is subordinate to the background noise in the workplace, the presence of other machines and other factors that cannot be assessed by the manufacturer in advance. The user therefore needs to make a phonometric measurement of the noise emitted by the machine during normal operation, and provide for personal protection devices (headsets) if the noise emission exceeds the threshold laid down in the regulations in force in the country where the machine is used.

2.7.4 Operator working position

During balancing the operator must stand in front of the control console and avoid standing in front of the wheel during the balancing cycle.

3.0 UNPACKING AND POSITIONING

3.1 Visual inspection

The packaging must be intact upon receipt, i.e.:

- There must not be any sign of collision or breakage
- There must not be any sign that it was exposed to sources of heat, ice, water, etc.
- There must not be any sign of tampering.

Any deformations indicate that the machine was knocked about during transport and may compromise proper machine functioning.

3.2 Checking the machine and equipment supplied

The main body of the machine, the relative accessories and the equipment supplied (as agreed with the manufacturer) must be in perfect condition. The supply is carefully checked before shipment, nevertheless it is advisable to check upon receipt that it is complete and in order.

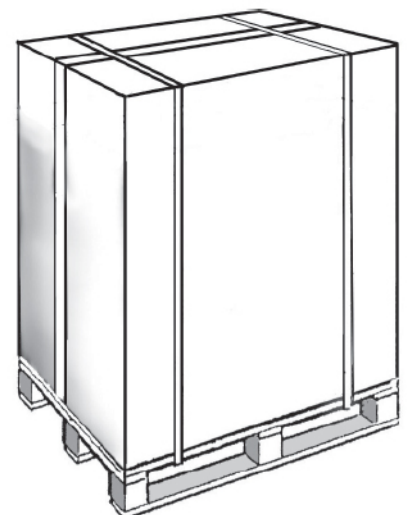

Check that:

- The shipping data (addressee, number of packages, order number, etc.) correspond to the accompanying documentation.
- The technical-legal documentation provided with the machine includes the instruction manual for the type of machine to be installed as well as the EC declaration of conformity or, alternatively, the declaration of the manufacturer.



INFORMATION

In the event of defects and/or missing material immediately notify the manufacturer and follow his instructions before proceeding with installation and startup.

3.3 Unpacking

Operate as follows to unpack the machine:

1. Cut the plastic safety straps
2. Open the top of the cardboard box
3. Remove the top protection
4. Remove any protective corner pieces
5. Remove the cardboard box pulling it upward
6. Remove any protective "pluriball"
7. Inspect the machine to check for any damage. Immediately inform the carrier and the supplier in the event of apparent damage.

Keep the packaging materials for possible future shipment of the machine.



INFORMATION

The packaging used is in compliance with the environmental requirements set out in the European packaging regulations (Official EC Gazette, N. L. 365/19). The cardboard boxes can easily be recycled. The plastic wrappings are made of materials free of hazardous metals. It is advisable to contact the competent local authority for their disposal.

3.4 Packing list

All the materials included in the supply are listed on the packing list. The contents may vary from machine to machine depending on the sales agreements, the optional parts supplied, etc.

Generally, the supply includes:

- the machine
- the toolbox
- the instruction manual

3.5 Storage

When the machine:

- is not immediately installed;
- is uninstalled and stored pending moving to another place position it in a covered place protected against direct contact with atmospheric agents and dust.

The permitted ambient values in the storage area are as follows:

- Temperature: +5 to +40°C (41 - 104°F)
- Relative humidity: 30÷80 %.

If taking the machine out of service after a period of use and after performing the necessary maintenance operations, it can be stored for a period of not more than two years, provided that it is stored in a closed dust-free environment without aggressive agents and with the following characteristics:

- Ambient conditions as described above
- Positioned in such a way that it is protected against deformation, crushing, breakage, etc.
- Not subjected to knocks, vibrations, overhanging loads, etc.

3.6 Handling

The term “handling” means unloading the machine from the means of transport and positioning it in the place where it will be used. Upon receipt the customer needs to unload the machine using his own means and store it in a dry and protected place pending installation.

The machine is to be handled while still fastened on the wooden pallet (see next paragraph) by suitably trained persons wearing the personal protection devices.



WARNING

Handle the machine with extreme care, lifting it the minimum necessary and avoiding dangerous oscillation and unbalancing. Before moving the machine, it must be tied to the lift truck (or transpallet) to prevent it from shifting and turning over.

Before lifting the machine with a lift truck or transpallet, make sure that the forks are properly positioned and protrude from the opposite side by at least 30 cm.

3.7 Removing the pallet

The machine is secured to a base pallet. Prepare an adequate area with level flooring and mark it off before lifting the machine and positioning it on the ground.

To remove the machine from the pallet operate as follows:

- Remove the screws that lock the machine to the pallet

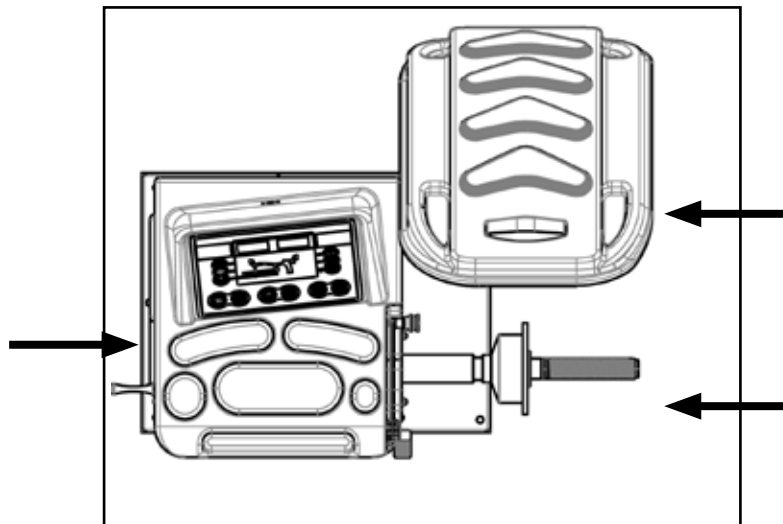

WARNING

Manual handling and lifting of the machine must be carried out with the aid of a lift truck. Prise on the base near the 3 support points as shown in the figure below. Other points, such as the head or the accessory tray, must not be forced under any circumstances.

3.8 Positioning

3.8.1 Warnings for positioning

The machine must be positioned respecting the following conditions:

- The humidity and the temperature must be within the prescribed limits
- The fire-fighting measures must be respected
- Allow for sufficient space at the front, side and rear of the machine for service or periodic maintenance and at the same time to assure adequate air circulation. It is advisable to leave a space of about 1 metre around the machine.
- The place where the machine is installed must be free of corrosive/explosive powders or gas.
- The place of installation must be vibration-free.
- The lighting must be such that the various machine functions can clearly be seen.
- Lift the machine and position it correctly in its final position
- The machine must stand on a flat rigid surface and possibly away from any joint in the floor.

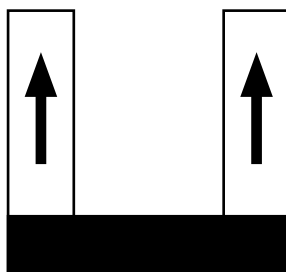
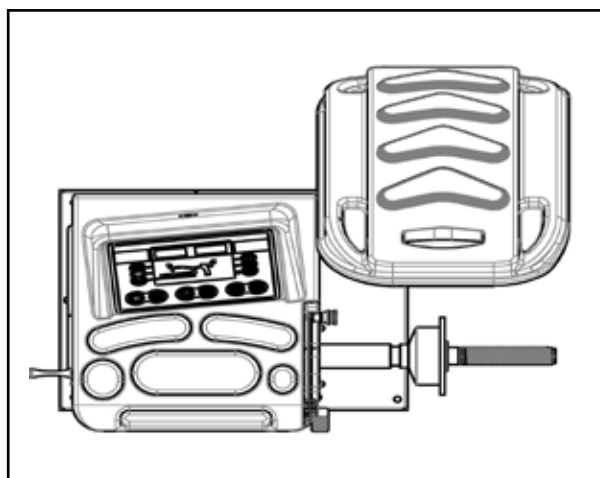

INFORMATION

According to UNI EN 10380 regulations, the lighting for a generic working area (such as control rooms, fixed workstations in production plants, etc.) must on average be 300 lux (acceptable values between 200 and 500 lux). If the machine is installed in a country different from Italy, the specific regulations in that country must be followed.

The lighting system must be such as to guarantee average lighting of 300 lux for the working environment. This value depends on various factors, such as the characteristics of the working environment (more or less reflecting walls and ceiling, height of the light points, etc.) and the type of bulbs used.

4.0 INSTALLATION



WARNING

The instructions in this chapter address the operator who must operate wearing the personal protection devices indicated in chapter 2.5.

4.1 Cleaning

Before starting the machine, clean off any dust, foreign matter and soiling that may have accumulated during transport. Use alcohol to clean the plastic parts.



CAUTION:

Do not use liquids containing solvents or blasts of compressed air to clean the wheel balancer.

4.2 Ambient characteristics

The operating environment must have the following characteristics:

- Temperature: + 5 to + 40°C (41 - 104°F)
- Maximum relative humidity: 80%

The machine may not be used in open places and/or exposed to atmospheric agents or in environments with corrosive and/or abrasive vapours, fumes or dust with the risk of fire or explosion, and in any case where the use of explosionproof components is prescribed.



CAUTION:

Should at the time of installation the ambient conditions be different from those prescribed, or if they have changed over time, do not use the machine but immediately contact the manufacturer for the relative inspection.

4.3 Fitting the adapters

INFORMATION

Before fitting the terminal to the wheel balancer, it is advisable to thoroughly clean the machine shaft and the adapter hole. Any traces of dirt may affect the balancing accuracy.

The wheel balancer is supplied complete with adapter and cones for fastening wheels with a central hole. The threaded terminal may already be fitted on the machine or be provided in the equipment box; to fit it use an Allen wrench as shown in the drawing. It can be removed to fit optional adapters.

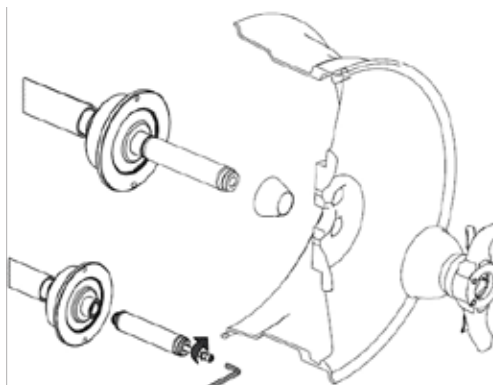

**CAUTION:**

Using non-original accessories might compromise the measuring quality. Contact the manufacturer for the supply of special Adapters or spare parts of any kind.

4.4 Electrical connection

4.4.1 Safety rules

Before performing any operation, read and apply the following:

- Make sure that the main electric cabinet to which the machine is connected is connected to the earth circuit and is adequately protected as required by the regulations in force in the country where the machine is installed. The socket to which the machine is connected must have a slow acting safety switch calibrated to 4 A (230V) or 8A (115V).
- Check that the mains voltage and frequency correspond to the values indicated on the machine identification plate.
- The socket to which the machine is connected must be dimensioned to support the power absorbed up to a maximum of 1.1 kW.

The machine is supplied with a single-phase cable to which a plug conform to the regulations must be connected. If an extension needs to be used, bear in mind that the wire cross-section may not be less than 2.5 mm². Make sure that the extension is arranged so that it does not constitute a risk or obstruction.

**WARNING**

The connection to the single-phase mains must always be made between phase and neutral and never between phase and earth! It is strictly prohibited to turn on the machine if it is not properly connected to earth according to the technical specifications set out in the regulations in force. In any event, the electrical connections must be carried out exclusively by a specialised technician.

4.4.2 Pneumatic connection

If the machine is equipped with a pneumatic locking/release spindle and/or WBL81 lift, it needs to be fed with compressed air at 8-10 bar. The compressed air must be clean and dry. The pipes and pipe fittings must be properly connected by appropriately trained personnel.

The warranty does not cover damage caused by the absence of an adequate air filtration system.

5.0 RESIDUAL RISKS

Residual risk means a potential risk impossible to eliminate or partially eliminatable, which may cause injury to the operator if operating using improper working methods and practices.

- Pay attention to the position of your hands in the areas indicated in the figure, as there is a risk of crushing your fingers during wheel locking on the spindle.

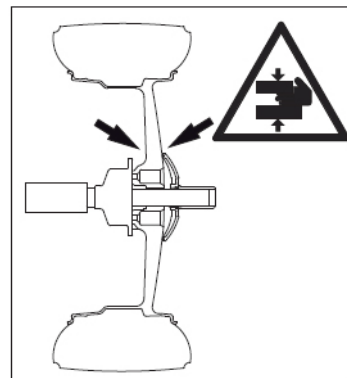

- While mounting or dismounting the tyre, pay attention to avoid accidentally crushing your feet.

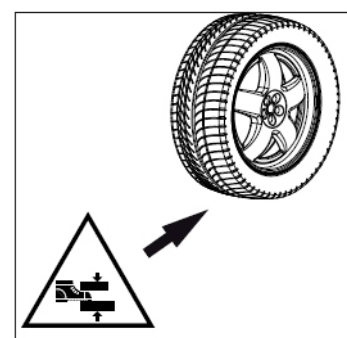

6.0 MACHINE DESCRIPTION

6.1 Purpose

Is used to balance the wheels of cars, vans, 4-WD, motorcycles and scooters weighing less than 75 Kg. It can be operated in the temperature range of 0° to + 45°C.

The machine can operate only on flat non resilient floor.

To lift the machine, lever only on the base where the 3 support points are located. never, under any circumstance, apply force to other points such as the spindle, head, or accessory shelf. It functions properly without having to fasten it to the floor with wheels weighing up to 35 kg; for heavier wheels, fasten it at the points indicated. Do not mount anything other than motorbike, car or truck tyres on the wheel balancer.

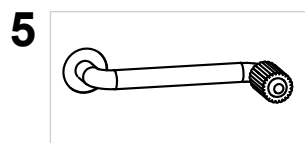
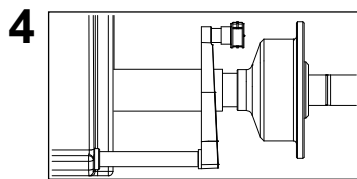
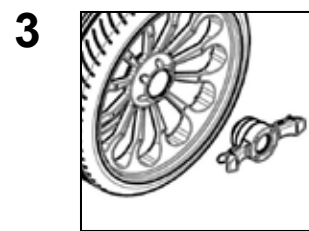

1. CONTROL PANEL
2. WEIGHT-TOOL HOLDER
3. LOCK NUT
4. AUTOMATIC GAUGE
5. BRAKE

The main features include:

- machine settings menu
- grams/ounces direct selection
- optimisation of tyre and rim unbalance
- static programme, ALU; SPLIT; double operator; self diagnostics; calibration.
- automatic minimisation of static unbalance

6.2 Technical specifications

The following data refers to the balancer in its standard configuration.

Single-phase power supply	230 V 50/60 Hz
Protection class	IP 54
Max.power consumption	0,12 Kw
Balancing speed	150 min ⁻¹
Cycle time for wheel	7 sec. (5 3/4"x14") 15 kg.
Measurement uncertainty	1 g
Average noise	< 70 dB (A)
Rim width setting range	1.5" ÷ 20" or 40 ÷ 510 mm
Diameter setting range	10" ÷ 30" or 265 ÷ 765 mm
Maximum wheel weight	≤ 75 kg.
Machine weight	93 kg.

6.3 Dimensions

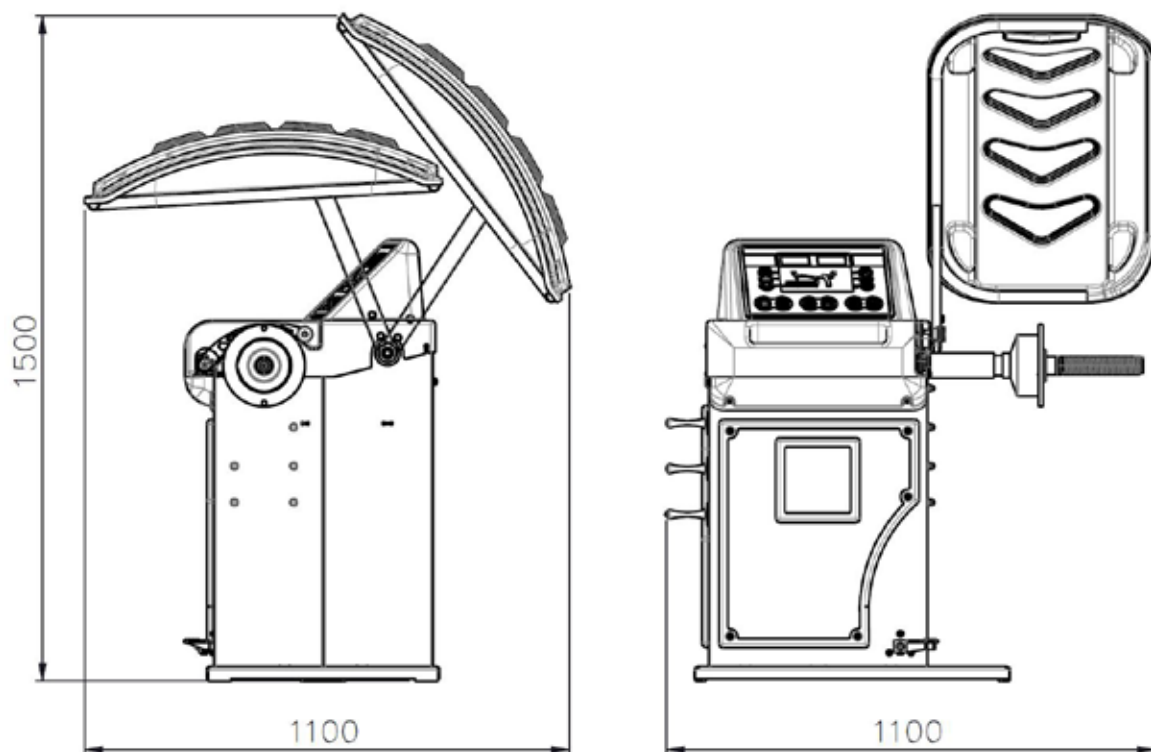

7.0 STARTING



WARNING

Before switching on the machine, make sure that all the connections described in the **INSTALLATION** chapter have been made correctly. The following operations involve a potential risk for the operator, given the presence of voltage on the equipment. The Personal Protective Equipment described in the **INSTALLATION** manual must be worn and work must be done with due care and attention. Operations may only be performed by a specialised technician.

Before powering the machine, carry out the following checks:

1. check that the balancing machine touches the floor at the three support points;

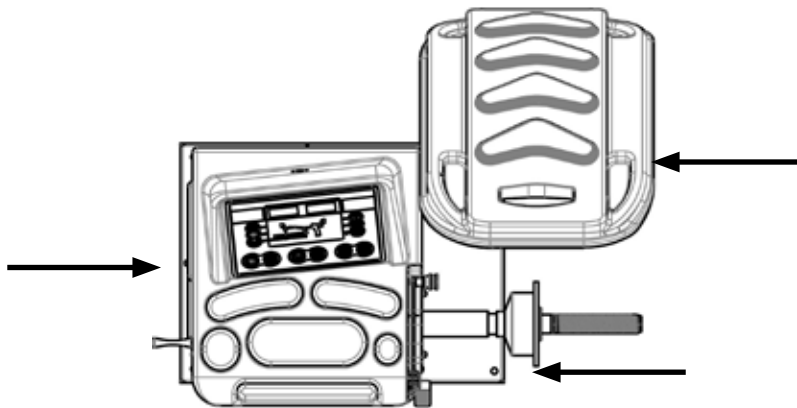

2. make sure that all the parts of the balancer are correctly connected and fixed;
3. make sure that the parameters (voltage and frequency) of the mains power supply are compatible with those indicated on the rating plate of the balancer;
4. make sure the power cable is correctly connected;
5. make sure the machine shaft and flange hole are clean.

NOTE - If the machine is not fixed to the ground, there are 2 adjustable screws inside its body, they have to be used to optimise the machine's balancing and stabilize it.





CAUTION
Any traces of dirt may affect balancing accuracy.

6. To switch on the balancer press the switch on the left-hand side of the machine.

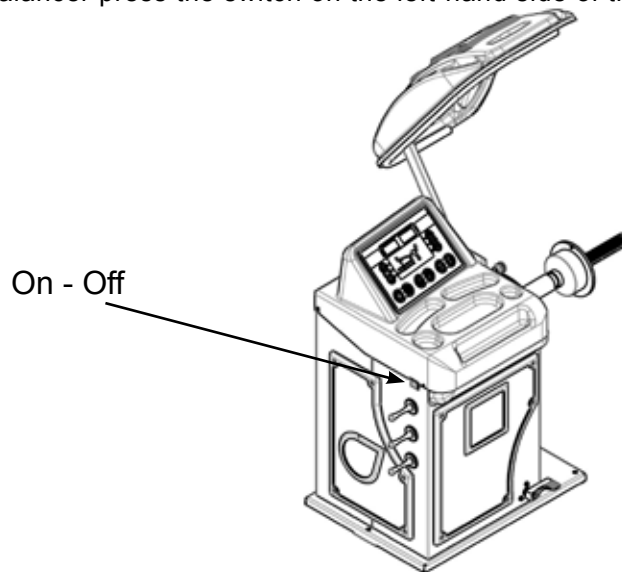

7. Position the wheel on the terminal with the inner part facing the balancer;

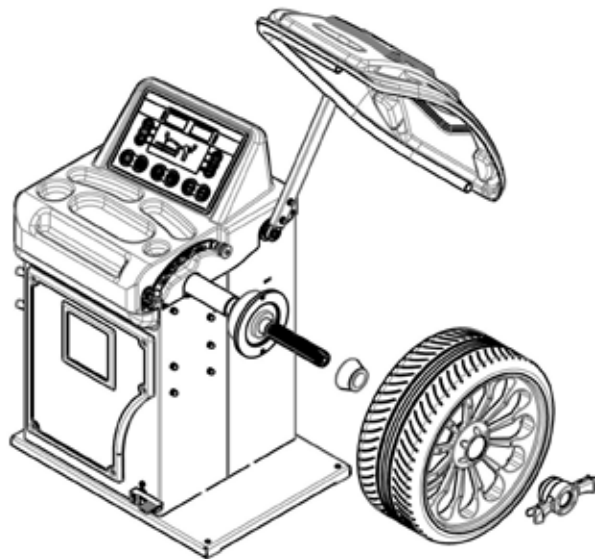

8. Firmly attach the wheel to the balancer shaft using the lock nut.

9. The pedal controls a mechanical brake which facilitates locking the locking ring and positioning the wheel for correction.

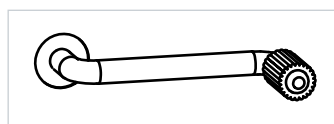

10. At this point, you can read the tyre measurements and perform balancing.

8.0 CONTROL PANEL

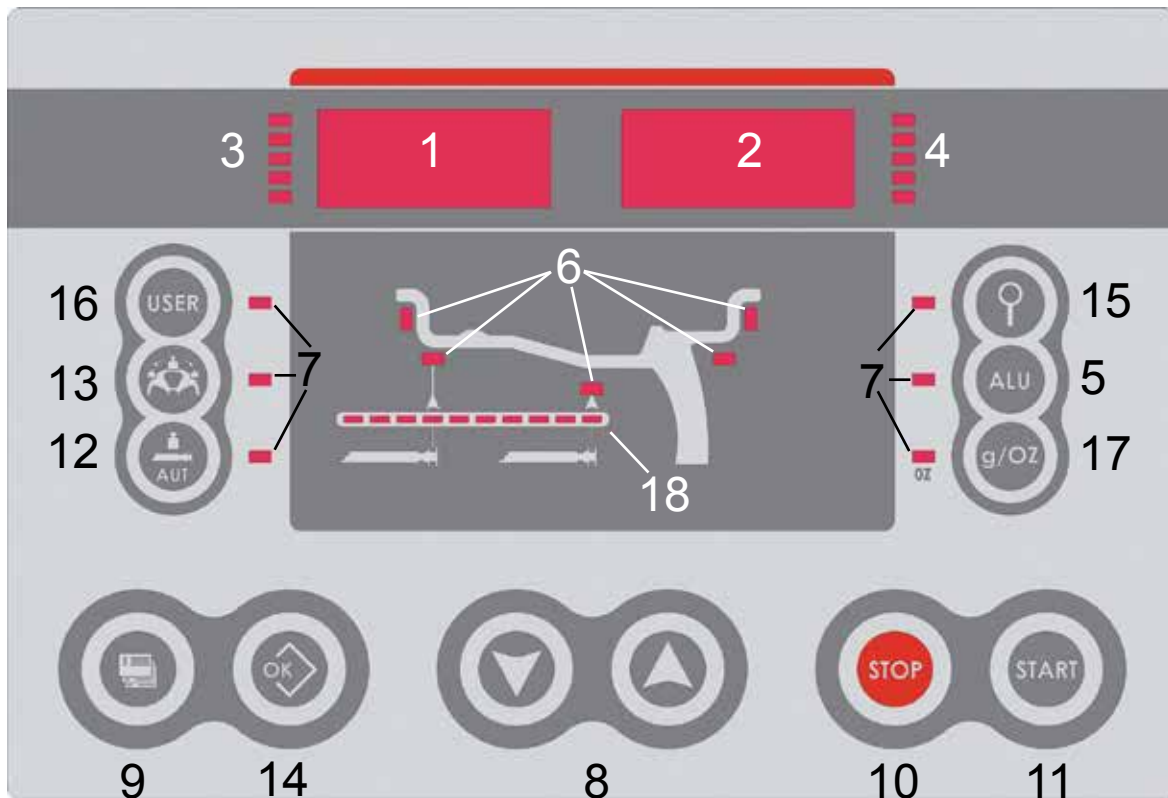

- 1-2 Digital readouts, AMOUNT OF UNBALANCE, inside/outside
- 3-4 Digital readouts, POSITION OF UNBALANCE, inside/outside
- 5 Inside correction mode selection button
- 6 Indicators, correction mode selected
- 7 Indicators, selection made
- 8 Manual WIDTH/DISTANCE/DIAMETER setting buttons and MENU selection
- 9 Push button, FUNCTION MENU
- 10 Balancing cycle stop button
- 11 Balancing cycle start button
- 12 Position repeater push button
- 13 Push button, SPLIT (unbalance resolution)
- 14 MENU selection confirmation pushbutton
- 15 Push button, unbalance reading < 5 g (.25 oz)
- 16 Push button, operator selection
- 17 Grams/ounces selection pushbutton
- 18 Distance gauge position indication



CAUTION

Press the buttons with your fingers.

Never use the counterweight grippers or other pointed objects!

9.0 USE OF THE WHEEL BALANCER

9.1 Presetting of wheeldimensions

The balancing data is set by means of an “intelligent” automatic gauge; confirmation of the measurement and the position appear on the display. The round part of the gauge must rest on the rim where the weight will be positioned.

Using the special grip, move the end of the gauge against the rim in one of the positions A/B shown in relation to the kind of repeater set (**TYPE OF REPEATER**).

- The measurement is the same in position A or B. If the correction type is with adhesive weights on the inside (ALUM), to enable the position repeater function, press the  button .

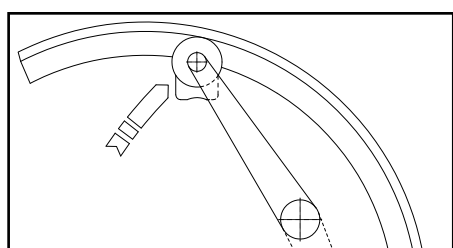

a

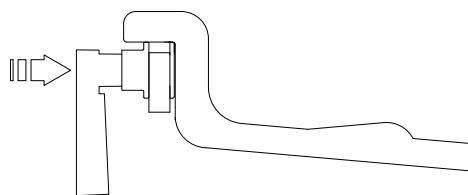

b

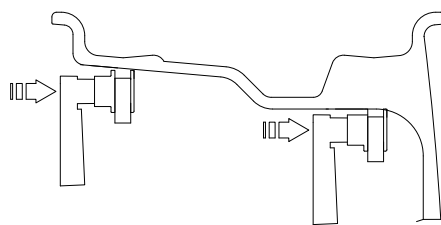

While the gauge is moving the following appears:



when the measurement has been stored:



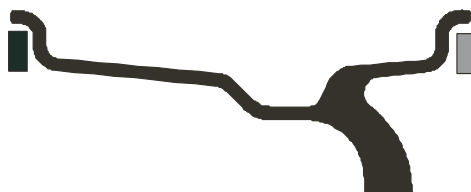

If the acoustic signal is enabled (**ACOUSTIC SIGNAL**), the acquisition of the dimensions is accompanied by a “beep”.

a) standard weights: when only one measurement is made, the machine interprets the presence of a rim with clip-on weight correction





9.1.1 ET (This function is available only in the absence of the LA sonar)

Enabling the ET function, after the end of the automatic distance and diameter measurement, the wheel balancer suggests the most likely width value for the dimensions just acquired. If necessary, change the width value by pressing the   buttons, otherwise proceed with normal balancing.



CAUTION

The ET function does not work with the adapters

If the ET function is disabled, the width value (b) must be set with the   buttons. The correct measurement is that which can be measured with the compass gauge provided.

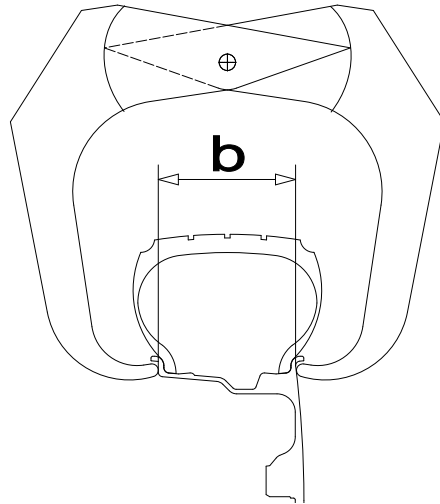

b) adhesive weights: make two successive measurements on two correction planes inside the rim.

The balancing machine automatically interprets that the correction will be made with adhesive weights and the following appears:

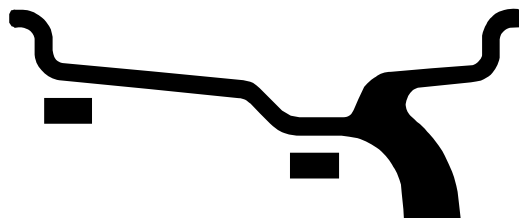

For a different combination of the type or position of the weights on the rim, use the button .

 ALU

9.1.2 Modifying set dimensions

If the wheel dimensions have been entered incorrectly, the parameters can be modified without repeating the balancing spin by pressing for 2 seconds :

 access parameter modification → (select   to modify: (a) distance, (b) width, (d) diameter

In the case of standard weights:

(a) distance, (b) width, (d) diameter

In the case of adhesive weights:

(a1) inside distance, (a2) outside distance, (d1) inside diameter, (d2) outside diameter press  to select (a) (b) or (d)

→  to recalculate the unbalance or:

pull out the gauge to repeat the measurement →  to obtain the new measurement.

9.2 Measurement result

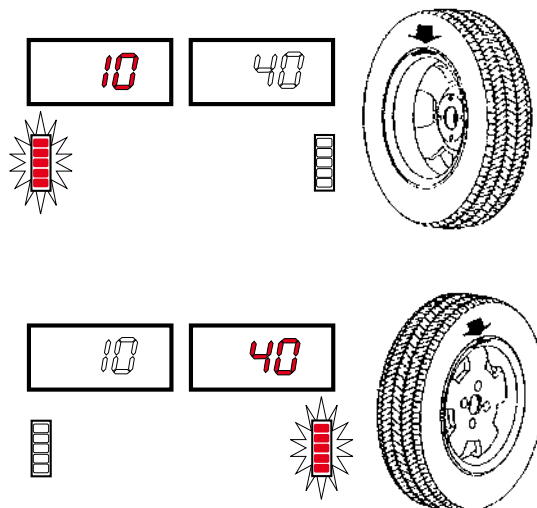

Move the wheel manually until all the LED's corresponding to the side light up. The display shows the measured unbalance. Pressing **STOP** the chuck can be locked/released in any position to facilitate mounting the wheel (see **MENU**).

For unbalance within tolerance **0 (zero)**; using  values within tolerance can be viewed.

After positioning and locking the wheel, apply the weight vertically at the top.

9.3 Static unbalance

It is selected by pressing  and is shown on the central display. The position is indicated on the displays 3 and 4.

9.4 Exact positioning of the adhesive weight by means of the gauge with clips

- Press  if using the correction method with adhesive weights on the inside of the rim

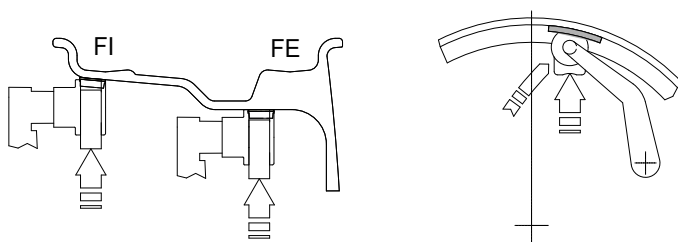

- Fit the correction weight in the specific gauge seat with the adhesive part facing upwards
- Bring the wheel into correct angular position for the plane to be corrected.
- Pull the gauge further outwards.
- Return the gauge to the rest position.
- When the weight application distance has been reached a beep is sounded (can be deactivated)
- Rotate the gauge until the correction weight adheres to the rim
- the fact that the weight application position is no longer vertical is automatically compensated



INDICATION

The approach of the weights to the correction positions is indicated by the LEDs number 18

- Inside correction position

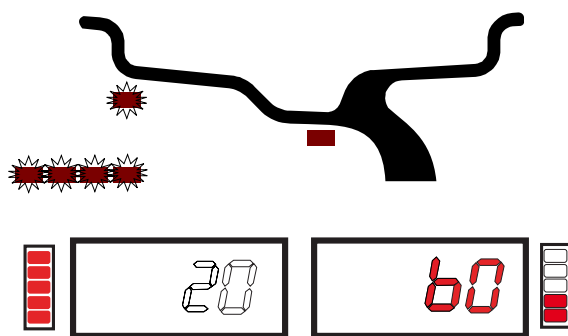

- Outside correction position

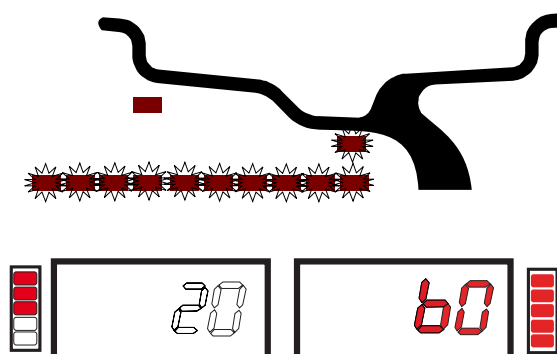

To cancel the function, press the  button again.

9.5 SPLIT function (unbalance resolution)

The SPLIT function is used to position the adhesive weights behind the wheel spokes (angle > 18°) so that they are no longer visible (for alloy rims). Use this function in the ALU or STATIC mode where the adhesive weight is applied inside the rim.

Enter the wheel dimensions in the ALU M mode and press START.

a. Turn the wheel to the outer side unbalance correction position.

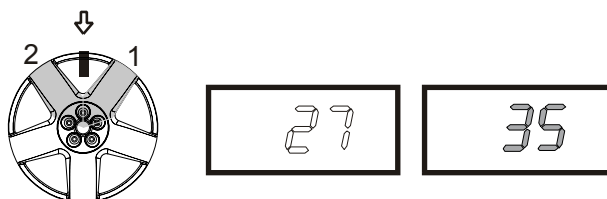

b. Move one of the spokes to 12 o'clock (e.g.: 1) and press 

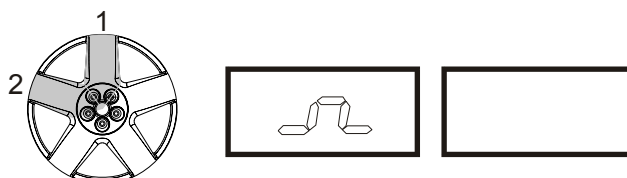

c. Following the direction of rotation indicated by the position LED's, move spoke 2 to 12 o'clock and press



The value to use for correction in position 2 is displayed.

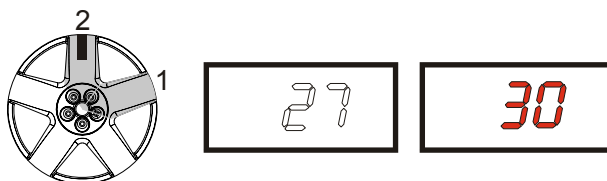

d. Move spoke 1 to the correction position as indicated by the position LED's

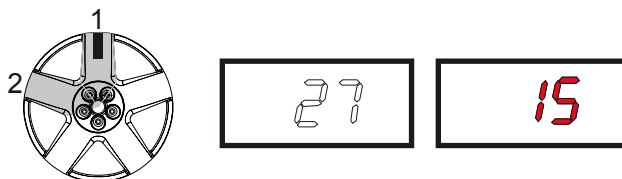

INDICATION

If the OP function is enabled, see the chapter OPPOSITE POSITION for application of the weights at the bottom.

To return to the normal unbalance indication press any button.





INFORMATION

The spoke-to-spoke distance must be a minimum of 18° and a maximum of 120° (if not, errors 24, 25 or 26 appear). Spokes with irregular or inconstant angles can be compensated.

9.6 Double operator program

This program allows memorizing the dimensions of two types of wheels. Thus two operators can work simultaneously on two different cars using the same balancing machine. The system memorizes two programs with various present dimensions.

1. Press  to select the operator (1 or 2).
2. Enter the dimensions (see **WHEEL DIMENSIONS PRESETTING**)
3. Press  to carry out the balancing as usual and to automatically store the program to the currently selected user.

Press  to select program 1 or 2 for subsequent balancing operations without setting the dimensions again.

9.7 Automatic minimization of static unbalance

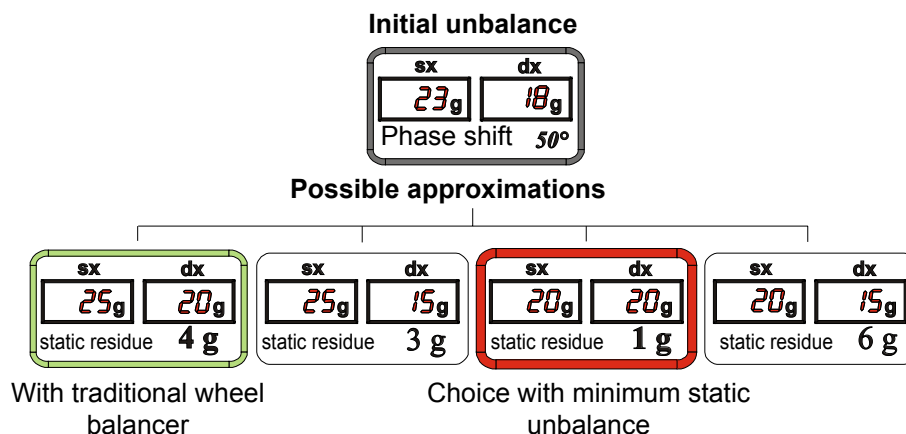

This program is designed to improve the quality of balancing without any mental effort or loss of time by the operator. In fact by using the normal commercially available weights, with pitch of 5 in every 5 g, and by applying the two counterweights which a conventional wheel balancer rounds to the nearest value, there could be a residual static unbalance of up to 4 g. The damage of such approximation is emphasized by the fact that static unbalance is cause of most of disturbances on the vehicle. This new function, resident in the machine, automatically indicates the optimum entity of the weights to be applied by approximating them in an "intelligent" way according to their position in order to minimize residual static unbalance.

10.0 SETUP

10.1 Menù

This is used to personalise some balancer functions and to perform calibrations.
To access this section, press the FUNCTIONS MENU button.

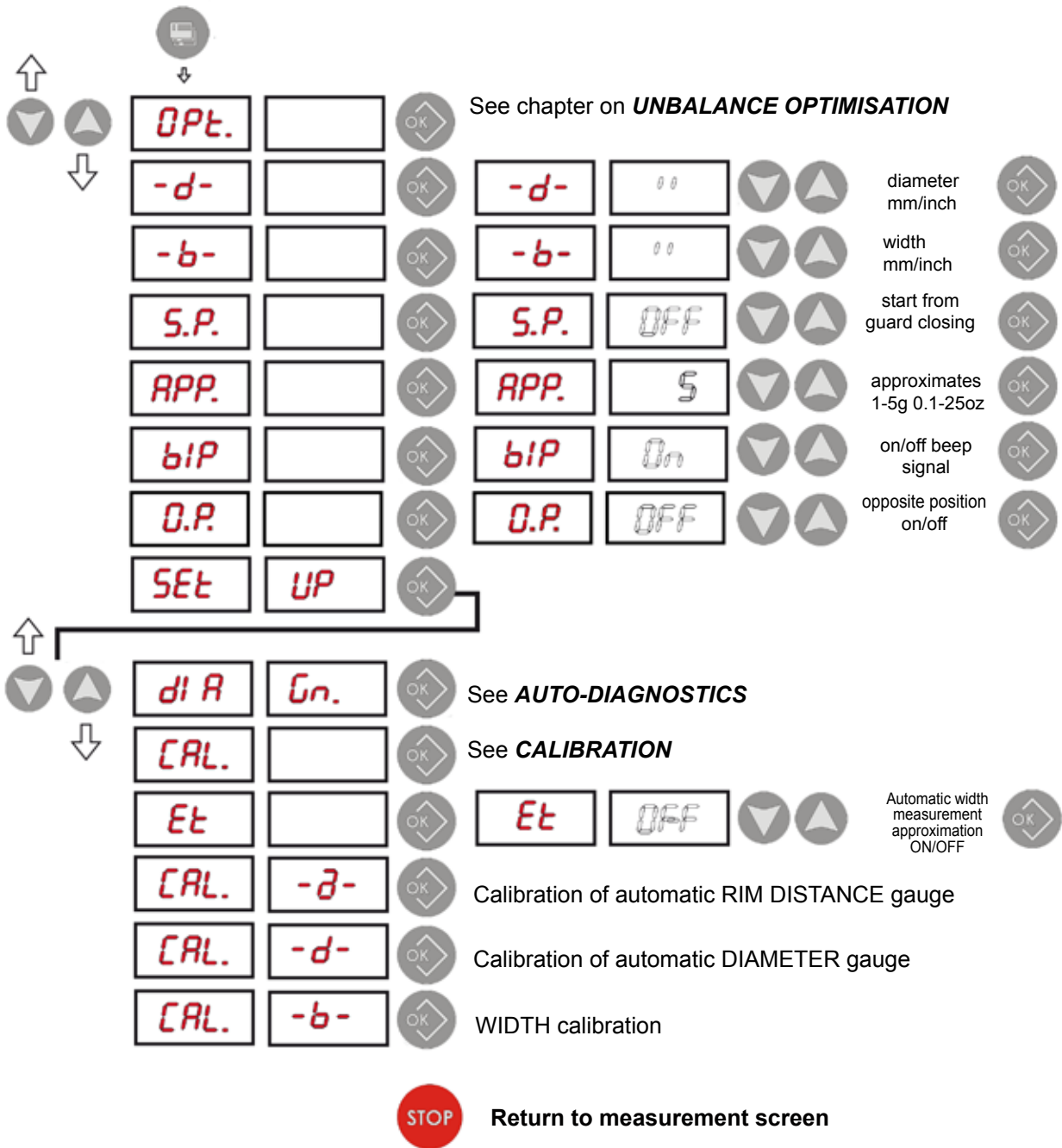

INFORMATION

* The ET function is available only in the absence of the LA sonar

10.2 Unbalance optimisation

This operation is performed to reduce the static unbalance of the wheel. It is suitable for static unbalance values in excess of 30 grams.



a. If no unbalance was measured before, START appears on the display. Press this button to proceed.

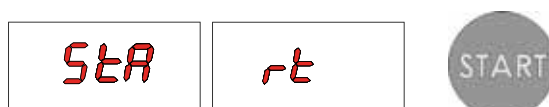

b. Make a reference mark on the flange and the rim (using a piece of chalk, for example). With the aid of a tyre remover, turn the tyre on the rim by 180°. Refit the wheel in such a way that the reference marks on the rim and the flange coincide.

Press START to begin reading.



c. RH display: percentage reduction value
LH display: actual static unbalance value which can be reduced by rotation



d. Mark the two positions of the rim and tyre, and turn the tyre on the rim until the positions coincide to achieve the optimisation shown on the display

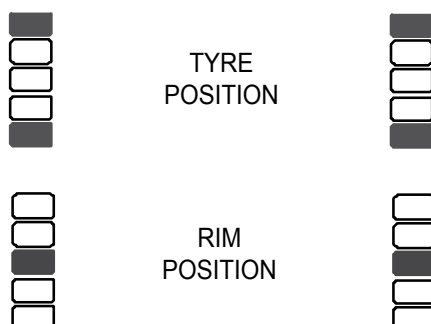

To cancel optimisation at any time, press



10.3 OPPOSITE WEIGHT FUNCTION (OPF)

The normal balancing condition requires the correction weights to be applied at the top (12 o'clock) when the symbol is displayed:

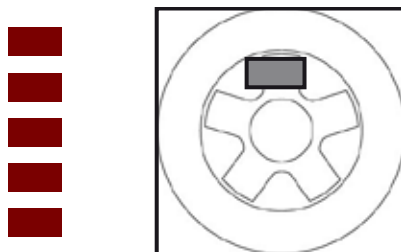

If "OPPOSITE WEIGHT FUNCTION (OPF)" is enabled, the phase displays also indicate the weight application position at the bottom (6 o'clock) to facilitate cleaning the rim and the relative application of adhesive weights. The symbol used is:

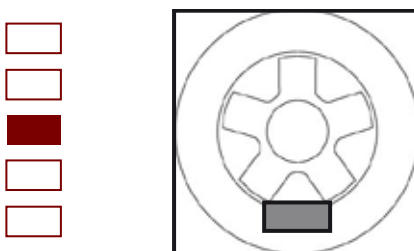

10.4 Self-diagnostics

The machine can perform self-diagnostics to check the LED's on the control panel and make sure the encoder reads correctly.

To perform this operation, view the SETUP menu.



In the self-diagnostics sequence, all the LED's on the panel light up for a few seconds in order to check operation. When the LED's go out, the machine automatically moves on to the encoder reading phase. When the wheel is turned manually (forwards and backwards), the display shows its exact position. The value lies between 0 (zero) and 255.

10.5 Calibration

To calibrate the machine, proceed as follows:

- Fit an average size wheel with a metal rim on the shaft. Example: 6" x 15" (± 1 ").
- Set the wheel measurements as described in paragraph **USE OF THE WHEEL BALANCER**.





CAUTION



Setting incorrect dimensions would mean that the machine is not correctly calibrated, Therefore, all subsequent measurements will be incorrect until calibration is performed once again with the correct dimensions.

Display the **SETUP** menu:

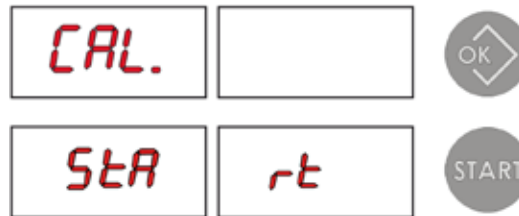

1. Press   to view the CALIBRATION function.



2. Add a standard weight of 60 g (2.00 oz) to the outer side, in any position. Failing a weight of 60g (2.00oz) press   to change the calibration weight from 40 to 100g (1.40 to 3.50oz)



3. Shift the standard weight from the outside to the inside keeping the same position.



4. Turn the wheel until the standard weight is at the top (12 o'clock).



5. End of calibration.

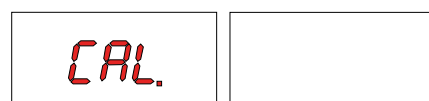



To cancel calibration at any time, press



10.6 Automatic gauges calibration

10.6.1 Rim distance gauge

Display the *SETUP* menu

1. Press   to view the rim distance gauge CALIBRATION function.

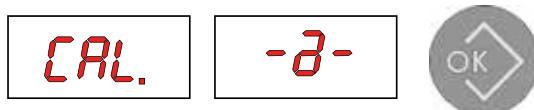

2. Leave the distance gauge in rest position and press

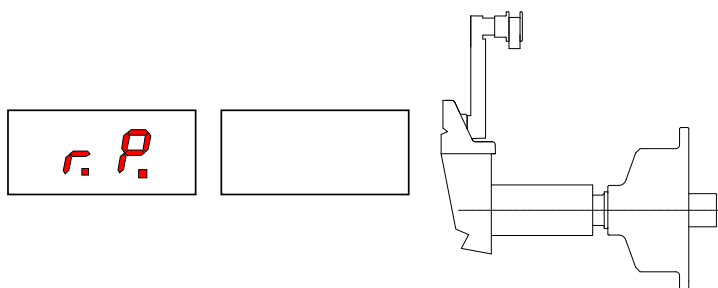

4. Bring the gauge in line with the adapter flange and press



CORRECT CALIBRATION

- Return the gauge to rest position.
- The wheel balancer is ready for operation.



INDICATION

In the event of errors or faulty operation, the writing "r.P.": appears on the display : shift the gauge to the rest position and repeat the calibration operation exactly as described above. If the error persists, contact the Technical Service Department. In the event of incorrect input in

the rim distance gauge calibration function, press

STOP





to cancel it.

10.6.2 Diameter gauge

Display the *SETUP* menu:



1. Press   to view the diameter gauge CALIBRATION function.

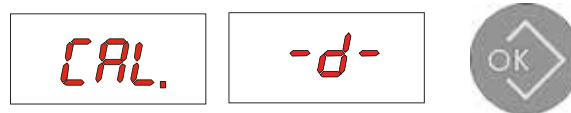

2. Place the gauge rod on the spindle shell as shown in the figure and press OK

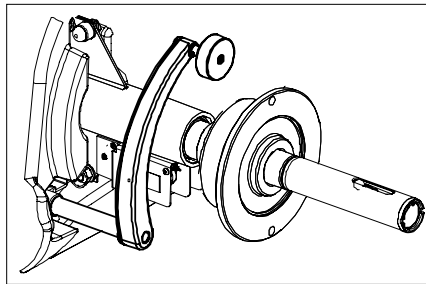
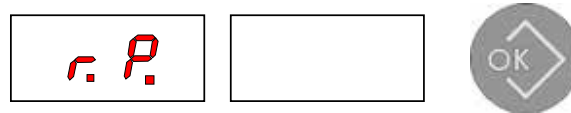

3. Turn the gauge downward positioning the gauge rod in contact with the spindle sleeve as shown in the

figure and press OK

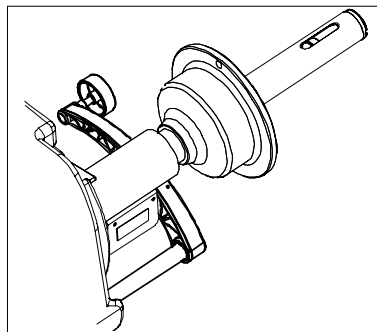
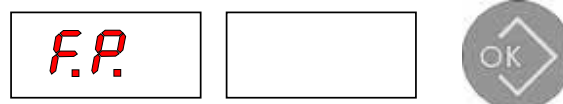



CALIBRATION COMPLETE

- Return the gauge to rest position.
- The wheel balancer is ready for operation.





10.6.3 Width sonar (option)

Display the *SETUP* menu

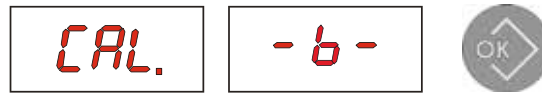
1. Press   to view the width sonar CALIBRATION function.



2. Set with   the distance in mm between the Sonar sensor (0 sonar) and the end of the distance gauge (at rest).



A = Distance: Gauge at rest to 0 sonar

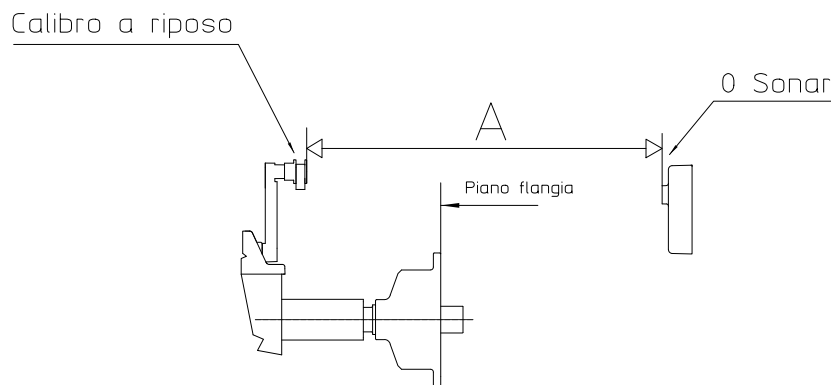

In the event of incorrect input in the width gauge calibration function, press  to cancel it.

11.0 DIAGNOSTICS

11.1 Inconsistent unbalance readings

In some cases, when a wheel that has just been balanced is repositioned on the balancer, the machine can detect an unbalance.

This is not a machine problem but is due to faulty mounting of the wheel on the flange. In other words, when mounting the wheel after initial balancing, it has taken another position with respect to the balancer shaft axis.

If the wheel has been mounted on the flange with screws, the screws may not have been tightened correctly (criss-cross sequence) or the tolerances of the holes drilled in the wheel may be too large. Small errors, up to 10 grams (0.4 oz), are to be considered normal in wheels locked with the relative cone: The error is normally greater for wheels locked with screws or studs.

If, after balancing, the wheel is still unbalanced when refitted on the vehicle, this could be due to an unbalanced brake drum or, very often, the tolerances of the holes drilled in the rim and drum are too large. In this case, balancing should be performed using a balancer with the wheel mounted on the vehicle.

11.2 Alarm signal

The machine has a self-diagnostics cycle which identifies the most frequent malfunctions during the normal work cycle.

These malfunctions are processed by the system and shown on the display.

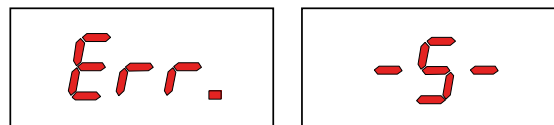



WARNING

The information in the **POSSIBLE REMEDY** column requires work to be performed by specialist technicians or other authorised people who must always work using the Personal Protective Equipment indicated in the **INSTALLATION** manual. In some cases, this work can be performed by a normal operator.

ERROR	CAUSE	POSSIBLE REMEDY
Black	The wheel balancer does not switch on.	<ol style="list-style-type: none"> 1. Check the machine is properly connected to the mains power supply. 2. Check the fuses on the power board and replace if necessary. 3. Replace the CPU board.
Err. 1	No rotation signal.	<ol style="list-style-type: none"> 1. Use the self-diagnostics function to check the encoder. 2. Replace the encoder. 3. Replace the CPU board.
Err. 2	Speed too low during detection. During the unbalance measurement revolutions, the wheel speed has fallen to below 42 rpm.	<ol style="list-style-type: none"> 1. Make sure that a vehicle wheel is mounted on the wheel balancer. 2. Use the self-diagnostics function to check the encoder. 3. Disconnect the piezo connectors from the board and do a spin (if no error is detected, replace the piezo sensors). 4. Replace the CPU board.
Err. 3	Unbalance too high.	<ol style="list-style-type: none"> 1. Check the wheel dimensions setting. 2. Check the detection unit connections. 3. Run the machine calibration function. 4. Mount a wheel with more or less known unbalance (less than 100 grams) and check the response of the machine. 5. Replace the CPU board.
Err. 4	Rotation in opposite direction.	<ol style="list-style-type: none"> 1. Use the self-diagnostics function to check the encoder. 2. Check the encoder bearing/spring.
Err. 5	Guard open The [START] pushbutton was pressed without first closing the guard.	<ol style="list-style-type: none"> 1. Reset the error. 2. Close the guard. 3. Verify the function of the protection switch. 4. Press the [START] button.
Err. 7 Err. 8 Err. 9	NOVRAM parameter read error	<ol style="list-style-type: none"> 1. Switch off the machine and wait for at least ~ 1 min; re-start the machine and check it works properly. 2. Repeat machine calibration. 3. Replace the CPU board.
Err. 11	Too high speed error. The average spinning speed is more than 240 rpm.	<ol style="list-style-type: none"> 1. Use the self-diagnostics function to check the encoder. 2. Replace the computer board.
Err. 14 Err. 15 Err. 16 Err. 17 Err. 18 Err. 19	Unbalance measurement error.	<ol style="list-style-type: none"> 1. Use the self-diagnostics function to check the encoder. 2. Check the detection unit connections. 3. Check the machine earthing connection. 4. Mount a wheel with more or less known unbalance (less than 100 grams) and check the response of the machine. 5. Replace the CPU board.
Err. 20	Wheel still. The wheel must remain still for more than one second after START.	<ol style="list-style-type: none"> 1. Use the self-diagnostics function to check the encoder. 2. Check the connections on the power board. 3. Replace the CPU board.
Err. 21	Motor on for more than 15 seconds.	<ol style="list-style-type: none"> 1. Use the self-diagnostics function to check the encoder. 2. Check the connections on the power board. 3. Replace the CPU board.
Err. 22	Maximum number of spins possible for the unbalance measurement has been exceeded.	<ol style="list-style-type: none"> 1. Check that a vehicle wheel has been mounted on the wheel balancer. 2. Use the self-diagnostics function to check the encoder. 3. Replace the computer board.

Err. 24	Distance between the spokes less than 18 degrees.	<ol style="list-style-type: none"> 1. The minimum distance between the spokes where the unbalance is to be split must be greater than 18 degrees. 2. Repeat the SPLIT function increasing the distance between the spokes.
Err. 25	Distance between the spokes greater than 120 degrees.	<ol style="list-style-type: none"> 1. The maximum distance between the spokes where the unbalance is to be split must be less than 120 degrees. 2. Repeat the split function increasing the distance between the spokes.
Err. 26	First spoke too far from the unbalance	<ol style="list-style-type: none"> 1. The maximum distance between the unbalance position and the spoke must be less than 120 degrees. 2. Repeat the split function increasing the distance between the spokes and the unbalance.

12.0 MAINTENANCE

12.1 General



CAUTION

Before performing any maintenance operations, make sure the machine has been disconnected from the mains power supply. Always use the Personal Protective Equipment indicated in the Installation Manual.

12.1.1 Introductory notes

This machine has been designed so as not to require routine maintenance, apart from accurate periodic cleaning. It is important to keep the machine perfectly clean in order to prevent dust or impurities from compromising the operation of the balancer.



WARNING

The people responsible for cleaning the area where the machine is installed must wear personal protective equipment in order to work in safety and according to the current occupational health and safety regulations.

As extraordinary maintenance must be performed by service staff or, in any case, by specifically authorised and trained people, is not dealt with in this manual.

12.1.2 Safety rules

Performing specialist activities on the equipment, particularly if the guards need to be dismantled, exposes people to serious danger due to the presence of potentially live parts.

The rules shown below must be scrupulously followed.

People must always use the Personal Protective Equipment indicated in the Installation Manual. During activities, unauthorised people may not access the equipment and WORK IN PROGRESS signs will be erected in the department in such a way that they are visible from every place of access.

Specialist staff must be authorised and especially trained concerning the dangers that may arise during operation and the correct methods for avoiding them.

They must always work with great care and pay full attention.

If, exceptionally, the staff removes the guards to carry out a particular specialist technical maintenance, inspection or repair job, they are required to put them back after work.

After work, staff must make sure that foreign objects, in particular mechanical pieces, tools or devices used during the operative procedure that could cause damage or malfunctions are not left inside the balancer.

For safety, before starting work, maintenance, inspection and repair staff must disconnect all power sources and take all the necessary preventive safety measures.

As well as operating frequencies, the operations described below indicate the qualifications that staff must possess in order to perform the operation.

12.1.3 Replacing fuses

Some protection fuses are located on the power board (see wiring diagrams) accessible by dismantling the weight shelf). If fuses require replacement, use ones with an identical current intensity.

13.0 DISPOSAL



CAUTION

The instructions in this chapter are indicative. Refer to the regulations in force in the country where the equipment is used.

13.1 Disposing of the balancer

The balancer must be disposed of after dismantling the various parts.

For disposal operations, as well as wearing the Personal Protective Equipment indicated in the INSTALLATION MANUAL, refer to the instructions and diagrams in this manual. If necessary, request specific information from the manufacturer.

Once you have removed the various parts and components, separate them into the different types of materials according to the differentiated waste disposal regulations in force in the country where the machine is dismantled.

If the various components must be stored before being taken to the dump, make sure to keep them in a safe place protected from atmospheric agents in order to prevent them from contaminating the ground and the water table.

13.2 DISPOSING OF ELECTRONICS COMPONENTS



Community directive 2002/96/EC, assimilated in Italy with legislative decree n° 151 of 25th July 2005, requires electrical and electronic equipment manufacturers and users to comply with a number of obligations concerning the collection, treatment, recovery and disposal of this waste.

Please scrupulously comply with these waste disposal regulations.

Remember that abusive dumping of this waste leads to the application of the administrative penalties established by current law.

14.0 SPARE PARTS

14.1 Identification and ordering method

The various parts can be identified using the drawings and diagrams in the machine technical file which is archived by the Manufacturer to which a request can be made.

For off-the-shelf parts, the technical manuals or the supplier's original documents can be provided if the Manufacturer deems this to be useful.

If not supplied, this documentation is also included in the machine Technical File, archived by the Manufacturer, as regards by Ministerial Decree 98/37/EC.

In this case, contact the Technical Service to identify the required piece.

If the required pieces are not in any position or they cannot be identified, contact the Technical Service, specifying the type of machine, its serial number and year of construction.

This information is indicated on the machine identification plate.

15.0 ATTACHED DOCUMENTATION

If not supplied, this documentation is included in the Technical File of the machine, archived by the Manufacturer.

In this case, contact the Technical Service for detailed information concerning the machine.

